

## **A METHODOLOGY TO EVALUATE THE PERFORMANCE AND CONSUMPTION OF VEHICLES IN COMPARATIVE ON-ROAD TESTS**

<sup>1</sup>Ghodsirad, Mohammadhossein\* ; <sup>1</sup>Teixeira, Joao; <sup>3</sup>Breda, Paulo; <sup>3</sup>Campos, Cristina; <sup>1,2</sup>Serrano, Luis; <sup>1</sup>Gameiro da Silva, Manuel

<sup>1</sup>ADAI-LAETA, Department of Mechanical Engineering, University of Coimbra, Portugal

<sup>2</sup>IPL, School of Technology and Management, Polytechnic Institute of Leiria, Portugal

<sup>3</sup>Galp Energia, Lisbon, Portugal

### **KEYWORDS**

On-road tests; performance of IC engines; fuel consumption

### **ABSTRACT**

The main objective of the reported work was to develop a methodology to assess the fuel consumption and the efficiency of the propulsion system of passenger cars equipped with internal combustion engines in road tests carried out to compare the performance of fuels with different formulations. The examination has been done out in highway travels. A Peugeot 407 HDI station wagon, with a 2,0 liter engine, has been equipped with different measurement systems. The measurement equipment is based upon two vehicle data loggers. A real-time fuel consumption metering system is combined with a GPS logger in order to analyze trip fuel consumption with different conditions in speed and altitude. An OBD II data logger is also mounted and the analog outputs of two pressure sensor are also connected to it. OBD II provides the vehicle and engine information available at the CPU unit, while the pressure sensors are connected to three pressure taps placed on the front of the vehicle to provide information about the relative velocity between the car and the air and the flow angularity. In the test, the impacts of speed, acceleration, road slope and wind disturbance on fuel consumption were analyzed for different fuel formulations. The developed system revealed to be well adapted to the requirements of the research project, allowing an accurate measurement of the fuel consumption and all the relevant parameters related to the vehicle movement. The best compromise in terms of sampling parameters has been achieved with a data acquisition frequency of 10 Hz, being the values decimated to 1 Hz, with the exception of the fuel consumption that is analyzed for 10 s integration intervals.

### **INTRODCUTION**

Diesel engines are widely used for mass transportation and vital demand is meeting through it in all over the world. However, on the one hand, the growing need to reduce their environmental pollution and respiratory health effects[1-3], and on the other hand, the very high injection pressures [4] enforce a continuous novel additive expansion heading for a severe optimization in diesel engine performances and emissions. At the moment, there are many alternative diesel fuels available and there are different methods and tests to evaluate their performance. . There have been wide researches to use different additives or catalyzers for either emission reduction or engine performance improvement.

The majority of early works used engine test benches and chassis dynamometers to study the impact of different fuels on engine performances [4-14]. These tools and methods for engine performance evaluation were based on different engine running cycles, independently of vehicle characteristics, and this may be assumed as a research weakness. The reason is that small changes in vehicle controlling parameters such as rotational speed and engine torque may lead to a wide range of engine performance outputs, like consumptions and emissions. Therefore, it is more important to perform real-world measurements under real traffic conditions, which offers an appropriate approach to determine accurate consumption and emission rate.

There has been a wide research comparing the official and real-world fuel consumption and CO<sub>2</sub> emissions for cars in Europe and the United States. It was proved via different data resources that there was an increasing discrepancy between fuel consumption and CO<sub>2</sub> emissions, reported by manufacturers and vehicle owners[15]. Dings[16] fully explained why there is a growing gap between the official fuel consumption and CO<sub>2</sub> emissions of new passenger cars and official reports by manufacturers.

Serrano et al.[17] compared real on-road measurements compared with engine test bench and chassis dynamometer test, respecting the capability as regards real road driving conditions and environmental circumstances.

Vlioger[18] used PLU 401-108 flow metering system based upon volumetric sensors to assess fuel consumption. The travelled route and vehicle speed have been measure with an optical device.

Senda et al. [19] used a small size SUV with IDI diesel engine of 2.0 liter for on-road measurement of the vehicle engine performances. In this methodology, the fuel consumption rate was calculated indirectly through the measured values of the intake airflow rate (by von Karman vortex flow meter) as well as the air humidity and temperature. Yen et al.[20] concluded, based on the literature, that it would be the most accurate system to use GPS based travel logger mainly because of its short response time and highly integration with computer analysis programs.

Hu et al.[21] measured and analysed the on-road fuel consumption and emissions of 16 diesel taxis in China In order to measure the fuel consumption, exhaust flow rate from vehicle tailpipe was recorded by a SEMTECH-EFM mass flow measurement device. The fuel consumption and mass emissions were calculated indirectly and not efficiently based on pollutant concentration and exhaust mass flow rate.

Serrano et al [22] tested two similar diesel Renault vehicles, with the same age, mileage and characteristics. The test procedure was as close as possible to both cars, running exactly in the same circuits and traffic conditions, in order to allow the comparison of two different fuels in terms of vehicle fuel consumption and emissions. The test methodology involved an extra reservoir to measure the fuel consumption. In order to apply the reservoir to the fuel system, the normal supply and return lines were replaced by the new ones connected to the portable reservoir. The test procedure revealed to be accurate and reliable.

The methodology here presented tried to develop a new simple and accurate on-road measurement not only fulfil the need to have a reliable, easy to use procedure and capable of repeatability but also reduce the total performance costs and equipment prices. The proposed technique take advantage of on-board fuel consumption metering system together with Global Position System (GPS) and installed OBD system to communicate with the vehicle.

### METHODOLOGY

The measurement and data acquisition system which has mounted in the vehicle has been designed in order to allow sampling of the fuel consumption values at a high frequency, as well as all other parameters which may affect it. Thus, it has been considered essential to collect information about:

- The data for complete definition of the traveled routes, i. e. geographic coordinates (latitude, longitude and altitude) as well as the vehicle speed during the travel;
- The information available on the central processing unit of the motor vehicle, commonly known as ECU, in the same operation;
- The data to correct the changes on power released by the engine due to the occurrence of wind disturbances during the journey.

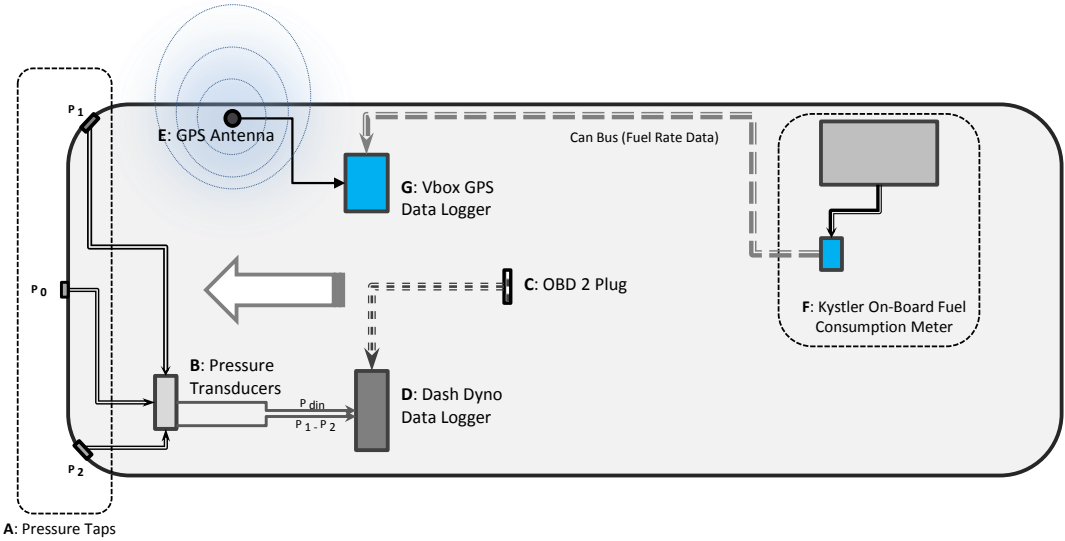

Figure 1 - Schematic representation of the measurement system fitted to the vehicle

The schematic representation of the assembled system is shown in Figure 1. The data logging equipment can be considered divided in two blocks. Block 1 consists of the equipment referenced in the schema as:

- A: set of pressure ports P0, P1 and P2
- B: Omega electrical piezoresistive pressure transducer, with a measuring range of  $\pm 2000$  Pa
- C: OBD II plug ("On- Board Diagnostics ")
- D: Auterra Dash Dyno Data logger

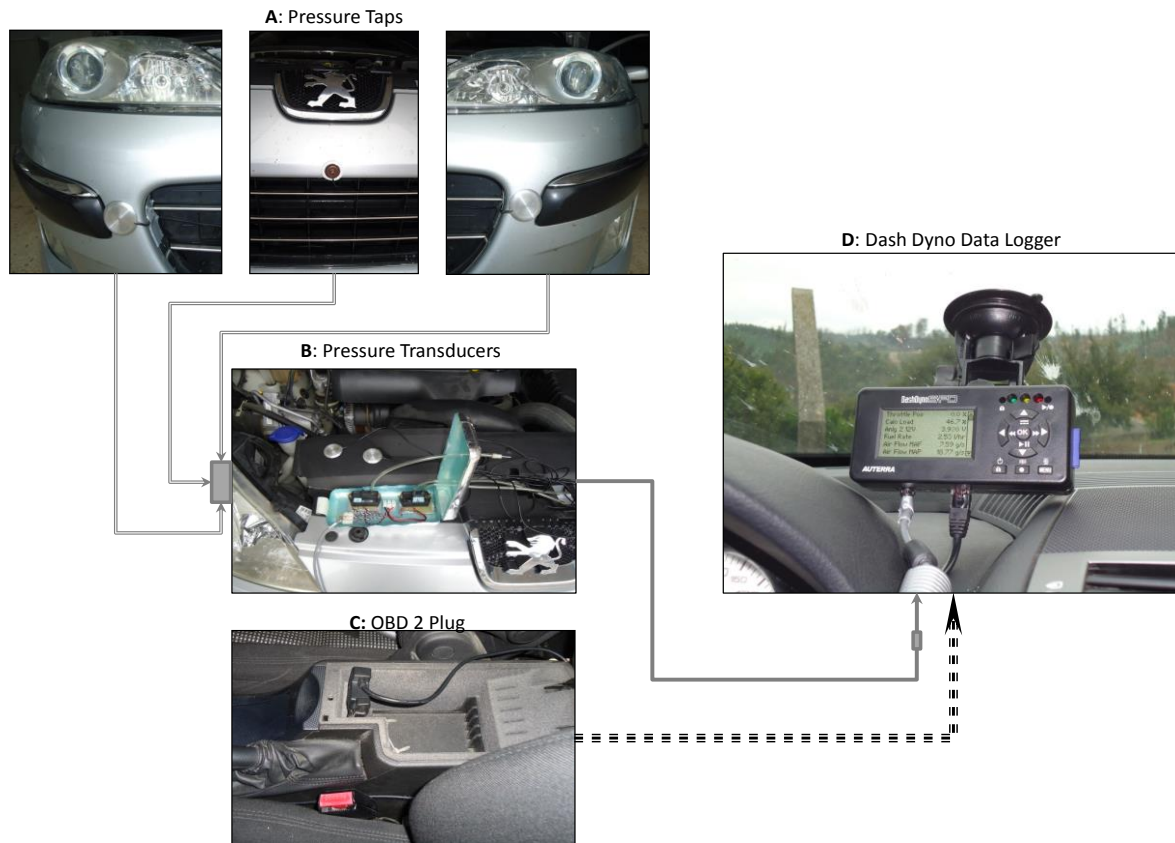

Figure 2 - Schematic representation of Block 1 fitted to the vehicle

Shown in figure 2 is a detailed diagram of the equipment and connections of Block 1. The connections represented between pressure taps and their transducers are plastic tubes. Electrical wires connected the electrical pressure transducers to the data logger. The OBD plug connection to the data logger is a multiwire electrical cable that transmits encoded digital signals in accordance with CAN bus protocol.

In Block 1 Data logger setup process (Auterra Dash Dyno), the following options are possible:

- To select up to 16 parameters among those that are available on the ECU to log in each test file;
- To choose between three possible data recording rates designated as Fast, Medium and Slow.

The selected variables to be recorded during the test are presented in Table I. They were considered to be the most relevant to document the engine operation evolution for the further analysis. In the Table 1, the information about the data registered in each channel of the data logger is given. Channels 3 and 7 correspond to analog voltage signals that are received from the pressure transducers connected to the P0, P1 and P2 taps. Channel 3 is recording the dynamic pressure of the flow stagnation zone in front of the vehicle. It is acquired from subtracting the value of the static pressure from the total pressure which is obtained from P0 outlet. To evaluate the angularity of the flow due to the effect of crosswinds, the difference pressure between P1 and P2 taps is recorded on channel 7.

Table 1 – Registered parameters from data available on the OBD 2

channel	parameter	channel	parameter
1	Abs Throttle Position	9	Fuel Used
2	Calculated Load	10	Engine Coolant Temp
3	Analog Input 2 - Pdin	11	Fuel Rail Pressure
4	Fuel Rate	12	Intake Air Pressure
5	Air Flow Rate MAP	13	Intake Manifold Pressure
6	Air Flow Rate MAF	14	Engine RPM
7	Analog Input 3 - Pdif	15	Vehicle Speed
8	Boost Pressure	16	Instant Economy

Block 2 includes the equipment which has referenced in the scheme of Figure 1, as

- E: external antenna of GPS system
- F : Kistler-Datron DFL3x 5bar on-board fuel consumption measuring equipment
- G Racelogic VB2SX10 Processing unit and GPS data logging system

Figure 3 represents the equipment and connections of Block 2 with more details. The GPS antenna is connected to the processing unit and data acquisition system by an electrical cable that transmits analog voltage signal, while the consumption metering system applied a multi strand wire which transmits a coded digital signal according to the Can- Bus communication protocol corresponding to the measured fuel consumption over a given interval time (0.1 seconds in this case).

Kistler-Datron DFL3x 5bar measurement system is used for the real time measuring the fuel flow rate consumed by the vehicle engine,. This equipment working principle is based on a positive displacement pump. Four pistons are used to keep constant the liquid level on a reservoir that is interposed in the fuel supply circuit. The instantaneous fuel consumption is determined from the positive pump displacement rotation speed, which is obtained from the frequency of a train of pulse generated by Hall effect sensors.

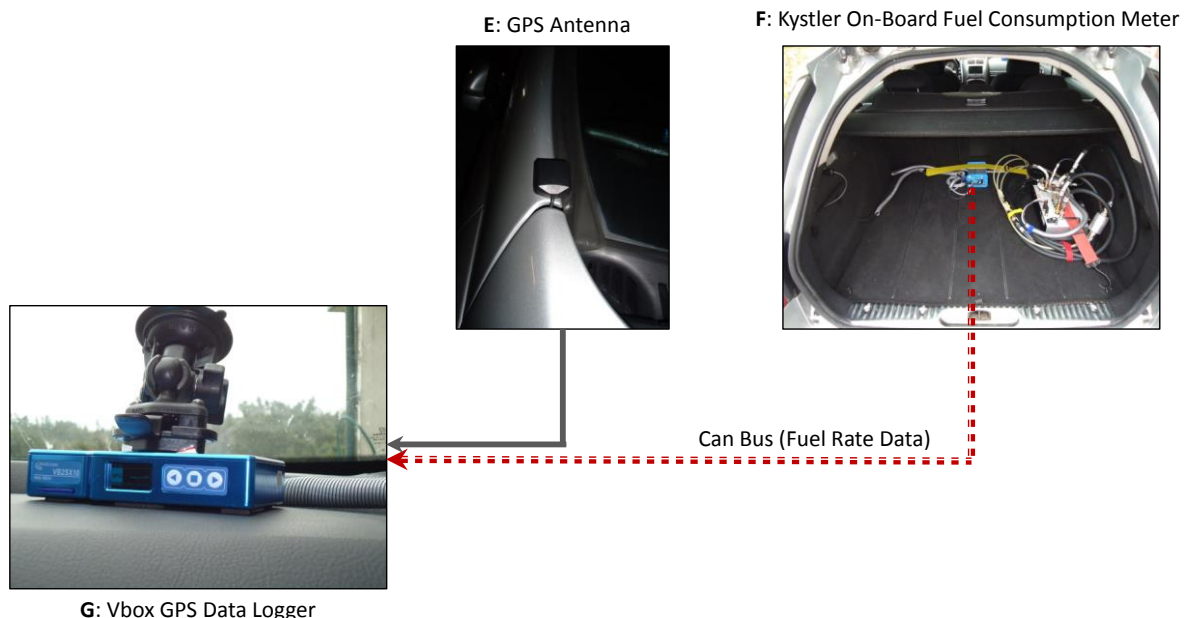

Figure 3 - Schematic representation of Block 2 fitted to the vehicle

The fuel consumption system Kistler Datron DFL3x-5bar has been installed in the luggage compartment of the vehicle (see Figure 4), as this was the most rational location for not taking up space in the cabin and easiness of accessibility to the fuel circuit, since the normal circuit pump is placed under the right back seat. The measurement system is interspersed with the so-called one-way circuit which runs from the fuel tank to the engine and also with the return circuit through which the fuel that is not injected to the engine returns to the tank.



Figure 4 - Details of the fuel metering equipment (Kistler Datron DFL3x - 5bar) installation in the trunk of the vehicle

Since the fuel consumption measuring equipment is not able to store the information, it was decided to communicate through the Can-Bus interface available in its processing unit. Thus, this signal is recorded in the GPS data logging system (VB2SX10 Racelogic), which records also the vehicle path data, after processing the GPS signal acquired with a frequency of 10 Hz. GPS data consists of geographical coordinates (latitude, longitude and altitude) and the vehicle traveling speed relatively to the ground.

## RESULTS ANALYSIS OF THE PRELIMINARY TEST

The results of the preliminary verification test of the measurement system are presented. Figure 5 presents several time evolutions of the measured signals during the trip. Most of the travel was done with the speed control activated with a setting velocity of 140 km/h. In Figure 5a) the signals of the displacement speed measured both by the GPS system, and by the vehicle speedometer are depicted.. The difference between the two signals is typically less than 0.7% of the measured value. The six detected disturbances during the constant velocity period correspond to zones of movement imposed at lower speeds due to works on the motorway or contingencies on traffic, usually associated with movement on the left lane of the highway of vehicles with speeds lower than 140 km/h. In the last ten minutes of movement between the two tolls, speed control was reduced to 130 km/h, because, on account of the occurrence of a greater traffic flow, it was difficult to keep the constant speed value which has been used previously. From the 88 to the 105 minute, it is the complementary route to the destination after leaving the highway.

Figure 5b) represents simultaneously the signals of altitude and measured fuel consumption at intervals of 10 seconds. The option to use an interval time of 10 seconds, in the case of fuel consumption, has been taken to enhance the signal to noise ratio. If the original sampling rate of 10 Hz (0.1 second integration time) is used to plot the data, the signal comes too noisy and difficult to analyses.

Analyzing the two signals of figure 6b), during the periods with a constant travel speed, a strong correlation between fuel consumption values and the rate of change of altitude (local slope of the road).is detected. The resolution of the fuel measurement system was 1.19 l/h for a time interval of 0.1 seconds. This value corresponds to a volume of 0,033 ml. If the interval time increases to 10 seconds, the resolution of the system passes to 0.0119 l/h. To have interval times of 10 seconds, computational tool was implemented for the post-processing of data in Labview programming language.

Figure 5c) represents the fuel consumption in l/100 km. since unit is more frequently used. The representation of this magnitude is done only during periods of constant speed movement, since when the vehicle is traveling at low speeds or is stopped, this indicator takes, respectively, very high values or infinite.

Following the minute 78, immediately after the occurrence of an event of high consumption, due to an acceleration phase to hold the constant speed in response to a need for braking, the vehicle travels a substantially flat area for 4 minutes, with slopes less than 0.1%. In this phase, the average consumption was 7.57 l/100 km, with a standard deviation of  $\pm 1.00$  l/100 km. This standard deviation value may be explained by variations in wind speed, the roughness of the floor and the slope of the road.

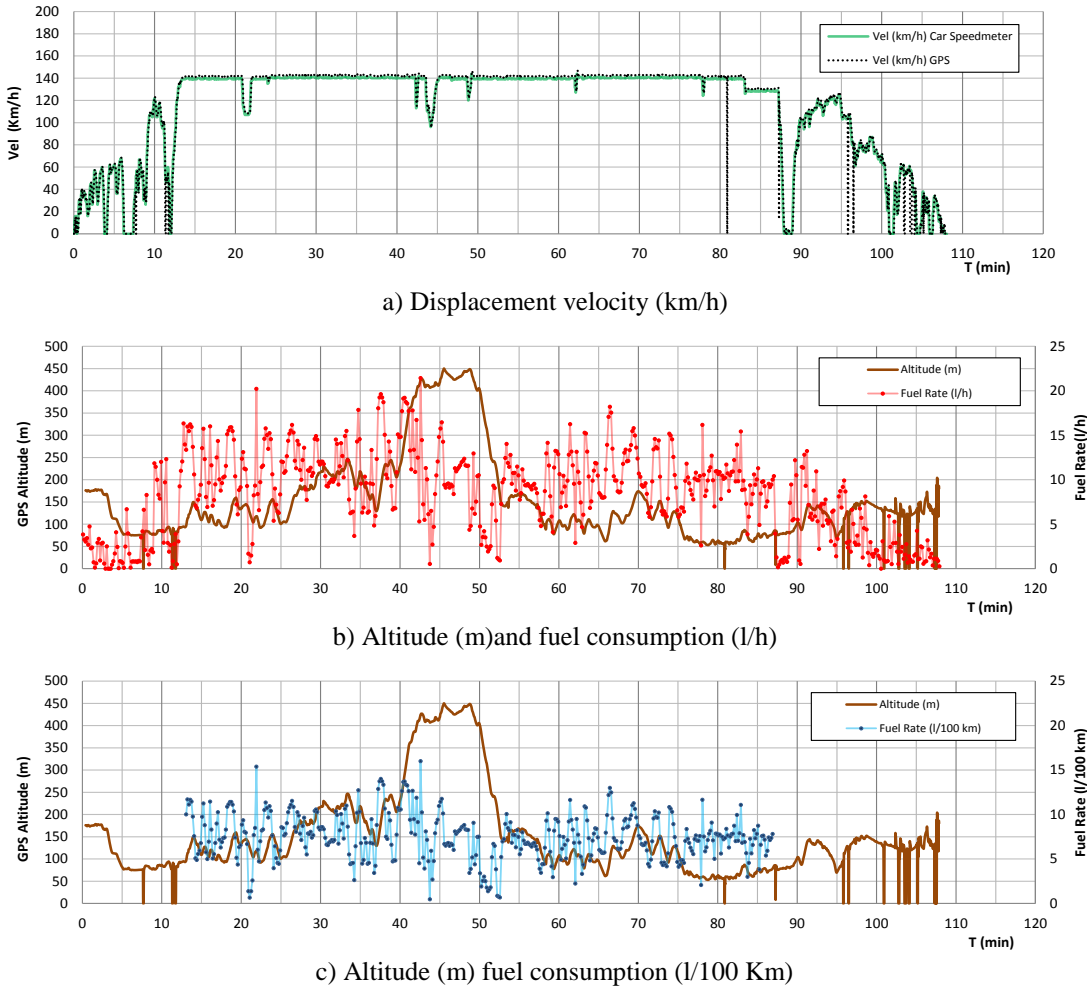
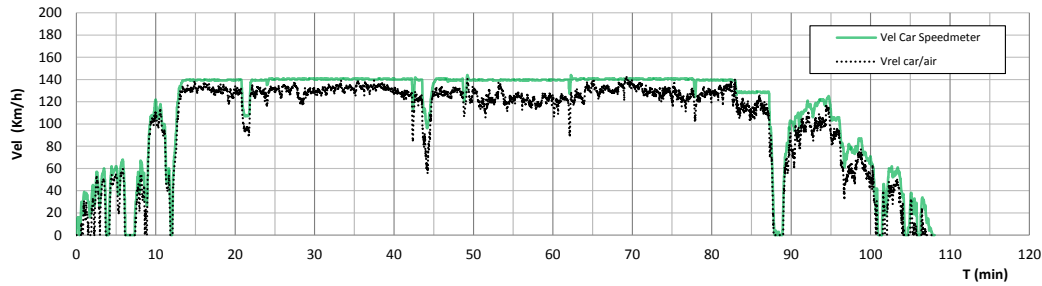

Figure 5 –Time evolutions of the measured signals during the road test

The time-based evolutions of the signals collected from the pressure sensors installed on the vehicle’s front, are shown in figure 6. In figure 6a), the black dots correspond to the calculated values of the vehicle/air relative velocity, based on the measured dynamic pressure from the pressure central tap in the front of the vehicle. During the travel time, the wind blew mostly North quadrant and the vehicle shifted from North to South, the movement occurred in a situation favorable wind (tailwind), which has the consequence that the vehicle/air relative speed is consistently lower than the vehicle/ground relative speed.

Figure 6b) represents the time-evolution of the pressure difference between the two lateral pressure taps, placed in opposite sides in the front of the vehicle. P1 is taken from the right side and P2 is taken from the left side. These pressure taps are designed to enable the angularity of the vector resulting from the composition of the vehicle speed with the wind speed. In this particular case, the angularity was low and since the right tap typically has higher values than the left one, the predominant wind was Northwest.



a) Relative speeds of the vehicle / vehicle and ground / air (km/h)

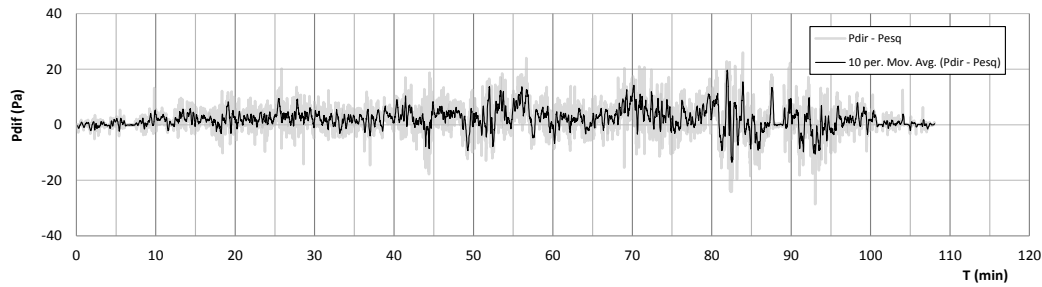

b) Difference pressure between P1 and P2 taps.

Figure 6 – Time evolutions of the signals from the pressure sensors

## CONCLUSIONS

Taking into account the obtained results in the preliminary tests which have been presented, it is possible to conclude that the level of precision, resolution and sampling frequency of the installed measuring system is suitable for the comparative study of fuels with different formulations, in terms of energy performance..

The report is not exhaustive, since a set of collected data from the OBD 2 plug (for example, temperatures, and motor fluid pressure) were not displayed although they are available.

It is being developed a methodology for the data post processing, with the aim of enabling a form of representation of records that will be useful in comparing the vehicle engine performances when supplied with fuels with different formulations.

Furthermore, the correlations between fuel consumption and the driving force on the wheels of the vehicle indicate good accuracy with which the data are being collected in the road tests.

## ACKNOWLEDGEMENT

The present work has been carried out on the framework of a research contract granted by GalP Energia, with the objective of creating the Fuel Development Lab, a R&D partnership involving Galp Energia, Universidade de Coimbra and ADAI.

## REFERENCES

- [1] C. Silva and A. Rivera, *Diesel Fuels: Characteristics, Performances and Environmental Impacts*: Nova Science s, Inc, 2013.
- [2] L. AC and C. TA, "Diesel engines: environmental impact and control," *J Air Waste Manag Assoc*, vol. 51, pp. 809-847, 2001.
- [3] S.-w. Lee, D. Tanaka, J. Kusaka, and Y. Daisho, "Effects of diesel fuel characteristics on spray and combustion in a diesel engine," *JSAE Review*, vol. 23, pp. 407-414, 10// 2002.
- [4] E. Arcaklioğlu and İ. Çelikten, "A diesel engine's performance and exhaust emissions," *Applied Energy*, vol. 80, pp. 11-22, 2005.

- [5] B. Aliyu, D. Shitanda, S. Walker, B. Agnew, S. Masheiti, and R. Atan, "Performance and exhaust emissions of a diesel engine fuelled with Croton megalocarpus (musine) methyl ester," *Applied Thermal Engineering*, vol. 31, pp. 36-41, 2011.
- [6] A. Kadarohman, Hernani, I. Rohman, R. Kusriani, and R. M. Astuti, "Combustion characteristics of diesel fuel on one cylinder diesel engine using clove oil, eugenol, and eugenyl acetate as fuel bio-additives," *Fuel*, 2012.
- [7] S. S. Gill, A. Tsolakis, J. M. Herreros, and A. P. E. York, "Diesel emissions improvements through the use of biodiesel or oxygenated blending components," *Fuel*, vol. 95, pp. 578-586, 2012.
- [8] M. Guru, U. Karakaya, D. Altıparmak, and A. Alicılar, "Improvement of Diesel fuel properties by using additives," 2002.
- [9] A. Keskin, M. Gürü, and D. Altıparmak, "Biodiesel production from tall oil with synthesized Mn and Ni based additives: Effects of the additives on fuel consumption and emissions," *Fuel*, vol. 86, pp. 1139-1143, 2007.
- [10] A. P. Sathiyagnanam and C. G. Saravanan, "Effects of diesel particulate trap and addition of di-methoxy-methane, di-methoxy-propane to diesel on emission characteristics of a diesel engine," *Fuel*, vol. 87, pp. 2281-2285, 2008.
- [11] M. A. Kalam and H. H. Masjuki, "Testing palm biodiesel and NPAA additives to control NOx and CO while improving efficiency in diesel engines," *Biomass and Bioenergy*, vol. 32, pp. 1116-1122, 2008.
- [12] M. Gumus and S. Kasifoglu, "Performance and emission evaluation of a compression ignition engine using a biodiesel (apricot seed kernel oil methyl ester) and its blends with diesel fuel," *Biomass and Bioenergy*, vol. 34, pp. 134-139, 2010.
- [13] K.-S. Chen, Y.-C. Lin, L.-T. Hsieh, L.-F. Lin, and C.-C. Wu, "Saving energy and reducing pollution by use of emulsified palm-biodiesel blends with bio-solution additive," *Energy*, vol. 35, pp. 2043-2048, 2010.
- [14] W. M. Yang, H. An, S. K. Chou, S. Vedharaji, R. Vallinagam, M. Balaji, *et al.*, "Emulsion fuel with novel nano-organic additives for diesel engine application," *Fuel*, 2012.
- [15] P. Mock, J. German, A. Bandivadekar, I. Riemersma, N. Ligterink, and U. Lambrecht, "From laboratory to road a comparison of official and 'real-world' fuel consumption and co2 values for cars in europe and the united states" International Council on Clean Transportation 2013.
- [16] J. Dings, "Mind the Gap! Why official car fuel economy figures don't match up to reality," Brussels, Belgium 2013.
- [17] Luis Serrano, José Costa, Manuel Silva, Impact of advances on computing and communication systems in automotive testing, Handbook of Research on Mobility and Computing: Evolving Technologies and Ubiquitous Impacts, IGI Global, 2011
- [18] I. D. Vlieger, "On-board emission and fuel consumption measurement campaign on petrol-driven passenger cars," *Atmospheric Environment*, vol. 31, pp. 3753-3761, 1997.
- [19] J. Senda, N. Okui, T. Tsukamoto, and H. Fujimoto, "On-Board Measurement of Engine Performance and Emissions in Diesel Vehicle Operated with Bio-diesel Fuel," *SAE paper* 2004.
- [20] K. S. Yen, T. A. Lasky, and A. Ayalew, "Application of High-Sensitivity GPS for a Highly-Integrated Automated Longitudinal Travel Behavior Diary," presented at the Institute of Navigation GNSS Conference, Fort Worth, TX, 2007.
- [21] J. Hu, Y. Wu, Z. Wang, Z. Li, Y. Zhou, H. Wang, *et al.*, "Real-world fuel efficiency and exhaust emissions of light-duty diesel vehicles and their correlation with road conditions," *Journal of Environmental Sciences*, vol. 24, pp. 865-874, 2012.
- [22] L. Serrano, V. Carreira, R. Câmara, and M. Gameiro da Silva, "On-road performance comparison of two identical cars consuming petrodiesel and biodiesel," *Fuel Processing Technology*, 2012.