



*Study on Gun Drilling Technology in CNC
Machining*

Master's degree in Product Design Engineering

Dhanush Kathiresan

Leiria, September of 2019



*Study on Gun Drilling Technology in CNC
Machining*

Master's degree in Product Design Engineering

Dhanush Kathiresan

Internship Report under the supervision of Doctor João Manuel Matias, Professor at
School of Technology and Management of the Polytechnic Institute of Leiria.

Leiria, September of 2019

Originality and Copyright

This internship report is original, made only for this purpose, and all authors whose studies and publications were used to complete it are duly acknowledged.

Partial reproduction of this document is authorized, provided that the Author is explicitly mentioned, as well as the study cycle, i.e., master's degree in Product Design Engineering, 2016/2019 academic year, of the School of Technology and Management of the Polytechnic Institute of Leiria, and the date of the public presentation of this work.

Acknowledgments

I would like to thank all professors of the Mechanical Engineering Department of the School of Technology and Management and to all teachers from other departments for all the knowledge they have given me throughout my journey in this institution, I must thank my professor Joao Manuel Matias for giving me an opportunity to gain exposure and knowledge about molds and Deep Hole Drilling and to complete my report on my internship throughout my course. I would also like to thank all the people from “TECNIMOPLAS” for helping me and passing over their knowledge to me.

Abstract

This document is the internship report of the Master in Product Design Engineering carried out at Tecnimoplás Lda. The company Tecnimoplás Lda is dedicated to manufacture of molds. They have an ability to make a small, medium and large size molds. Tecnimoplás is a company started in 1971 based in Marinha Grande, specialized in the service of mold.

With this internship it was possible to get the industrial immersion that was the one of the objectives of the student for this stage. In the company after an initial inclosing, it was possible to develop work in the different equipment's with different materials for mold in the company machines.

This statement is a detailed description and analytical analysis with various processes to make a mold. In this process one of the main process is Deep Hole Drilling. It is also talking about the various types of tools used in deep hole drilling machines and also discuss about the various types of fixing system in deep hole drilling machines. This deep hole drilling is mainly used for Water and Oil circuit in the mold. This report also comprises of case study of Deep hole drilling process and the void formation in the parts of Deep hole drilling machines.

This work also concluded that it is fundamental that the tools used in Deep Hole drilling, are used within the ranges of operation recommended by the tool's manufacturers.

Keywords: Moulds and its components;
Cooling system;
Deep Hole Drilling process.

Contents

Originality and Copyright.....	iii
Acknowledgments	iv
Abstract.....	v
List of Figures.....	xi
List of Tables	xv
List of Abbreviations and Acronyms	xvii
1. Introduction	1
1.1. Overview of Chapter	1
1.1.1. Chapter: 1	2
1.1.2. Chapter: 2	2
1.1.3. Chapter: 3	2
1.1.4. Chapter: 4	2
1.1.5. Chapter: 5	2
1.1.6. Chapter: 6	2
1.2. About Internship	2
1.3. Hosting Institution.....	3
2. About Tecnimoplás.....	5
2.1. Framework.....	5
2.2. Company Characterization	5
2.2.1. Location	5
2.3. Brief History of Tecnimoplás.....	6
2.4. Vision, Mission and Strategic Objectives	7
2.4.1. Vision	7
2.4.2. Mission	7
2.4.3. Strategic Objectives	8

2.5.	Market with Customer.....	8
2.5.1.	Project.....	8
2.5.2.	Production (Machining, Drilling, Erosion and Assembly)	8
2.5.3.	Commercial	8
3.	About Injection Plastic Industries	15
3.1.	Injection Moulding.....	15
3.2.	Industrial Revolution in Glass moulds	15
3.3.	Brief Overview of Plastic Industries.....	17
3.3.1.	First molds for Plastic Injection method	18
3.4.	Overview of Injection Molding process.....	19
3.4.1.	Molding Process	20
3.5.	Moulds for Injection of Plastic	21
3.5.1.	Types of moulds	22
3.6.	Mould Components and how it works.....	23
3.6.1.	Movable Half (Ejection Half)	24
3.6.2.	Spacer Blocks with ejection side base plate	25
3.6.3.	Ejector Retainer clamping plate	26
3.6.4.	Ejector Clamping plate	26
3.6.5.	Ejector Base plate	27
3.6.6.	Stationary Half (Injection side)	28
3.6.7.	Base plate in Stationary half.....	29
3.6.8.	Clamping plate for the Hot and Cold Runners circuit.....	29
3.7.	Injection Molding Machine	33
3.7.1.	Design of Injection Molding machine.....	33
3.7.2.	Clamping Unit	35
4.	Mould Cooling System	37
4.1.	Conventional Straight-Drilled cooling channel	37
4.1.1.	Parallel cooling channels.....	38

4.1.2.	Serial cooling channels	38
4.1.3.	Conformal cooling channels	39
4.2.	Remarks for cooling system.....	39
5.	About Deep Hole drilling	41
5.1.	Specification for Gun drilling.....	42
5.2.	BTA drilling	43
5.2.1.	Specification for BTA gundrill.....	44
5.2.2.	Different types of BTA drilling tool.....	45
5.2.3.	Deep hole Drilling process	45
5.2.4.	Rotating Tool.....	46
5.2.5.	Rotating Workpiece	46
5.3.	Highly Productive Gun drill tool.....	46
5.3.1.	Single lip Gun drill	47
5.3.2.	Double Lip Gundrill	48
5.3.3.	External chip removal method in Gun drill	49
5.4.	Different types of Drills.....	50
5.4.1.	Step Drill	50
5.4.2.	Core Drill.....	50
5.4.3.	Counterboring & Countersinking	50
5.4.4.	Centre Drill.....	51
5.4.5.	Spot Drill	51
5.4.6.	Spade Drill.....	51
5.4.7.	Crankshaft Drill	51
5.4.8.	Gun Drill.....	51
5.4.9.	Trepanning.....	51
5.4.10.	Twist Drill	51
6.	Case-study on Deep Hole Drilling	53
6.1.	Fixing System	53
6.1.1.	Normal Fixing System.....	53
6.1.2.	FPT (Fast mill) Fixing system.....	57

6.2.	Setup of Machines & Workpiece	60
6.2.1.	Technical Information about the Information	61
6.3.	About the Tools.....	62
6.3.1.	3D- Tester.....	62
6.3.2.	Drilling Tool.....	63
6.3.3.	Milling Tool	68
6.3.4.	Threading Tool.....	69
6.3.5.	Chamfer Tool	72
6.3.6.	Gun drilling Tool.....	73
6.3.7.	Conditions: 1 (1.1730/1.2344)	75
6.3.8.	Conditions: 2 (1.2311/1.2738)	77
6.3.9.	Condition: 3 (1.2711)	80
6.3.10.	Condition: 4 (1.2714).....	82
6.4.	Case-Study about Different angle of Intersection Holes.....	84
6.4.1.	Case-study 1: (Straight intersection hole with 90°)	85
6.4.2.	Case-study 2: (Cross intersection holes with 45°)	87
6.4.3.	Case-study 3: (Cross intersection holes with 30°)	89
6.4.4.	Case-study 4: (Cross intersection holes with 10° to 15°).....	90
6.4.5.	Case-study 5: Feed Rate and Spindle Rotation analysis	92
7.	Conclusions	95
8.	Bibliography	97

List of Figures

Figure 1 – Overview of the main production unit.....	4
Figure 2 – Company Outlook	6
Figure 3 – Tecnimoplás customer by sector	9
Figure 4 – Main Customer in Automotive field	10
Figure 5 – Business Volume per year.....	10
Figure 6 – Number of moulds manufacturing per year.....	11
Figure 7 – Samag (3-1500) Outlook view	11
Figure 8 – Working methodology of Samag (3-1500).....	12
Figure 9 – Traditional methodology for Glass mould	16
Figure 10 – Process for Injecting plastic [14].....	18
Figure 11 – Main 4 stages of Injection moulding process [27]	20
Figure 12 – Injection Mould plastic.....	21
Figure 13 – Two Plate Mould [13]	22
Figure 14 – Three Plate Mould [21]	23
Figure 15 – Movable Half (Core)	24
Figure 16 – Spacer Blocks with Ejector base plate.....	25
Figure 17 – Ejector Retainer clamping plate	26
Figure 18 – Ejector clamping plate.....	27
Figure 19 – Ejector Base plate.....	27
Figure 20 – Stationary Half (Injection half)	28
Figure 21 – Base plate in stationary Half	29
Figure 22 – Clamping plate for Runners	30
Figure 23 – Whole mould Outlook deign	31
Figure 24 – Injection Moulding Machine [8]	34
Figure 25 – Parallel cooling channel [8].....	38
Figure 26 – Serial cooling channel [8].....	38
Figure 27 – Conformal cooling channel	39

Figure 28 – Cooling channel circuit inside view in Cavity	40
Figure 29 – Gun drill tool specification [38].....	41
Figure 30 – Chip removal methodology in gun drilling [38]	42
Figure 31 – Gun drill D:d ratios	43
Figure 32 - BTA gun drill tool with plackets [39].....	44
Figure 33 – Single Lip gun drill tool.....	47
Figure 34 – Double Lip Gun drill tool	48
Figure 35 – External chip removal Gun drill tool	49
Figure 36 – T-slot table holder.....	53
Figure 37 – T-slot holder nuts	54
Figure 38 – Bar Clamps	55
Figure 39 – Step Clamp.....	56
Figure 40 - Step clamp tools (screws, nuts and clamps)	56
Figure 41 – Toe Clamp	56
Figure 42 - Pins	58
Figure 43 – Female Pin	59
Figure 44 – Fixing Method for Single Module	59
Figure 45 – Fixing method for Double Module	60
Figure 46 - Heto 2500 Master CNC machine.....	61
Figure 47 – 3D-Tester	63
Figure 48 – Rapid Drill	64
Figure 49 – Parameters for Rapid drill (Length vs Diameter of tool)	64
Figure 50 – Parameters for Rapid Drill (Spindle Speed vs Diameter of the tool)	65
Figure 51 – Parameters for Rapid Drill (Feed rate vs Diameter of the tool)	65
Figure 52 – HSS drilling tool (HIGH SPEED STEEL).....	65
Figure 53 – Parameters for HSS tool (Length vs Diameter of the tool)	66
Figure 54 – Parameters for HSS drilling tool (Spindle speed vs Diameter).....	66
Figure 55 – Parameters for HSS drilling tool (Feed rate vs Diameter)	67
Figure 56 – Milling Tool.....	68
Figure 57 – Parameters for Threading tool vs Pitch of tool (Normal pitch).....	69

Figure 58 – Parameters for Threading tool vs Drilling Diameter (Normal pitch)	69
Figure 59 – Parameters for threading tool vs Pitch of the tool (Fine Pitch)	70
Figure 60 – Parameters for Threading tool vs Drilling diameter (Fine Pitch)	71
Figure 61 – Comparison between Normal pitch vs Fine Pitch threading tool	72
Figure 62 – Comparison between drilling diameter (Normal vs Fine threading tool)	72
Figure 63 – Chamfer Tool	73
Figure 64 – General Parameters for gun drill tool (Tool diameter vs Spindle speed)	73
Figure 65 – General Parameters for gun drill tool (Tool diameter vs Feed Rate).....	74
Figure 66 – Parameters for Spindle speed vs Tool diameter (Condition: 1).....	76
Figure 67 – Parameters for Cutting Force vs Tool diameter (Condition: 1).....	77
Figure 68 - Parameters for Spindle Rotation vs Tool diameter (Condition:2).....	79
Figure 69 – Parameters for Cutting Force vs Tool diameter (Condition: 2).....	79
Figure 70 - Parameters for Spindle Rotation vs Tool diameter (Condition: 3).....	81
Figure 71 - Parameters for Cutting Force vs Tool diameter (Condition: 3).....	82
Figure 72 - Parameters for Spindle Rotation vs Tool diameter (Condition: 4).....	84
Figure 73 - Parameters for Cutting Force vs Tool diameter (Condition: 4).....	84
Figure 74 - Case-study 1: (Straight intersection hole with 90°)	86
Figure 75 - Case-study 2: (Cross intersection holes with 45°)	88
Figure 76 - Case-study 3: (Cross intersection hole with 30°).....	89
Figure 77 – Case-study 4: (Cross intersection holes with 10° to 15°).....	91
Figure 78 – Comparison chart between the Spindle rotation vs Different types of material list	92
Figure 79 – Comparison chart between the Material list vs Cutting Force	93

List of Tables

Table 1 – Cost estimation for different size of moulds.....	9
Table 2 – Technical Information about Samag (3-1500).....	12
Table 3 – Overview working of Movable half	28
Table 4 – Overview working of Stationary Half	30
Table 5 – Gun drill tool specification	42
Table 6 - Gun drill D:d ratios (Diameter: depth)	43
Table 7 - Differentiation table between the Gun drilling and BTA drilling tool	45
Table 8 - Highly Productive gun drill specification.....	46
Table 9 - Single Lip gundrill specification	47
Table 10 - Double Lip Gun drill tool.....	48
Table 11 - Different angles in gun drill tool	49
Table 12 – Different sizes for the Bar Clamp	55
Table 13 - Technical information about Heto 2500 master	62
Table 14 – Comparison table between Rapid Drill and HSS drilling tool.....	67
Table 15 – Specified used parameters in 1.1730/1.2344	75
Table 16 – Parameters for Condition: 1 (1.1730/1.2344)	76
Table 17 – Specified used parameters for Condition: 2 (1.2311/1.2738)	78
Table 18 – Parameters for Condition: 2 (1.2311/1.2378)	78
Table 19 - Specified used parameters for Condition: 3 (1.2711).....	80
Table 20 - Parameters for Condition: 3 (1.2711).....	81
Table 21 - Specified used parameters for Condition: 4 (1.2714).....	83
Table 22 - Parameters for Condition: 4 (1.2714).....	83
Table 23 – Parameters for Case-study: 1	86
Table 24 – Parameters for Case-study :2	88
Table 25 - Parameters for Case-study:3.....	90
Table 26 - Parameters for Case-study:4.....	91
Table 27 – Comparison Table between the Spindle Rotation vs Different types of material list	93

Table 28 – Comparison Table between the Material list vs Cutting Force 94

List of Abbreviations and Acronyms

AHA	Anibal Henriques Abrantes
APOREM	Associacao Portuguesa da Empreses com Museum
CAD	Computer Aided Design
CAM	Computer Aided Manufacturing
CAE	Computer Aided Engineering
CENTIMFE	Centro Tecnológico da Indústria de Mouldes Ferramentas Especiais e Plásticos.
CEFAMOL	Associacao Nacional da Indústria de Mouldes
CENFIM	Centro de Formacao Professional da Indústria Metalurgica e Metalomecanica.
CNC	Computer Numerical Control
PME	Pequena e Médias Empresas
SIPE	Sociedade Industrial de Produtos Eléctricos
BSPT	British Standard Pipe Threads
NPT	National Pipe Taper
BSW	British Standard White worth
UNU	Unified National Course
UNF	Unified National Fine

1. Introduction

This report contains the information about the Internship and the institution where took place the internship. The internship was completed in a company named “TECNIMOPLAS. Ltd”, in this duration internship work/report the guidance was given by Professor João Manuel Matias from the School of Technology and Management of the Politécnico de Leiria. The internship is as a part of the course Masters in Product Design Engineering in IPL, which includes the responsibility of an internship with the duration of about 9 months. During these 9 months, I gathered/learned more information about the Injection moulding process. Along with this, I learned about a specific technology called as “Deep Hole Drilling Technology”. So, in this report there is a separated chapter for the Deep Hole Drilling methodology, void formation in Deep Hole Drilling method and the parameters that affect for the optimisation for the process to make a perfect part.

In internship program started from the conventional saw cutting department at the very beginning. Followed by the Drilling, Erosion, Injection, Assembly and Milling department. The Time spent in each department depended upon the tasks and also the necessary time to understand the main point of the work done in each sector of each department [Conventional saw cutting- 2 weeks, Erosion- 2 weeks, Injection- 1 week, Assembly- 2 weeks, Milling- 2 weeks, Drilling- 6 months & 3 weeks]. In this report there is a brief information about the Moulds and Mould parts at the beginning, after which it has the standard components used to make a Moulds. Explaining all this information from the working experience and knowledge that was gathered during the period of internship. This report concludes with a study of Deep Hole Drilling technology and a case study information about the parameters that affects the Deep hole drilling technology.

1.1. Overview of Chapter

In this topic contains the overview of chapter.

1.1.1. Chapter: 1

In the current chapter it is done a brief explanation to various topics like General Overview of topic, about the internship and its working plan, about the company and main objective of the case study.

1.1.2. Chapter: 2

In second chapter, it contains history of Tecnimoplás and its main objective and characterization, vision & mission and also the framework of the company, finally we discuss about the main customers/dealers for the Tecnimoplás.

1.1.3. Chapter: 3

In third chapter, we are going to discuss the various sectors in mould plastic industries, Historical evolution of glass mould and origin of the injection moulding and about the technical evolution like (First mould for the plastic industry and overview of injection moulding types and its parts), full explanation of injection moulding machine and its design.

1.1.4. Chapter: 4

In fourth chapter, general overview of the cooling system in the moulds and its parts of the cooling system, brief overview of different types of cooling channel.

1.1.5. Chapter: 5

In fifth chapter, in this chapter we are going to discuss about the Deep Hole Drilling process and its types & specification like (chip removal method and Depth-diameter ratios of the gun drill). Different types of gun drills and its angle.

1.1.6. Chapter: 6

In sixth chapter, this a main chapter for this report. It contains case study of deep hole drilling method (First- about the fixing system of the work piece in the machine, Second- setup of the machines and its parameters, Finally- discuss about what are the problems it happens while we do the gun drill process).

1.2. About Internship

This Internship programs aims to contribute to the Deep Hole Drilling process in the moulds industry for plastic injection method, where this process is used to make holes for

the oil and water circuits in the cavities and cores. Is important to note that deep hole drilling is critical in the manufacturing process of the mould, because this is the most economical method of material removal in defining the piece geometry. In this way, most of the pieces passes through this section, so it is considered the heart of the production process in moulding industry. In this context, a process of innovative & sustainable Deep hole drilling when compared to the commonly used in conventional drilling process at that time we can find a different solution and different problems.

In this sector of the moulds, the drilling of the production process is a particularly relevant theme because rethinking the production process not only increases the competitiveness of enterprises through efficient processes, but also contributes to the protection of the environment from a sustainable perspective. Concerns about the environmental impact of the activity contribute to the sustainability of the company, as it enables costs to be lowered and their relationship with the market to be improved. This research focuses on the analysis of different tools strategies (conventional and sustainable) and the measurement of the feed rate and their times through the simulation process. It is intended to determine how the cutting and drilling parameters influence the time of production of moulds with different tonnage and to verify that the proposed drilling strategy, reduces the companies cost and their environmental impact. It is intended, through a process of simulation in software (like Work NC, Top solid) used on a daily basis in the company to create programs to measure the direct effects of drilling strategies simulated in the productive times and the indirect ones in the man-machine hours in the energy consumption in the environment.

1.3. Hosting Institution

The current introduction would take places at my Internship work place. In this chapter it contains the general overview about the work place name is called as the Tecnimoplás. General overview means about the company location and overview of the main production units with different departments.

Tecnimoplás is a company located in Marinha Grande (Embra) established in the year 1971 mainly specialized for Mould making. Mr. Noel Hugo Carlos and Mr. Luis Marrazes through their hard work and dedication developed the company with their efforts, following the footsteps of their parents, the founders of the company. “TO Injection” is a company (specialized in the plastic parts injection) part of the group led by Tecnimoplás. As a service

provider for making moulds the company is committed to meet the requirements of every customer and continuously satisfying all needs. Tecnimoplás is well equipped with latest CNC machine technology with dynamic team, which works tremendously with new and creative ideas. The company has a different department to design and manufacture the moulds like Drilling department, milling department, Erosion department, Grinding department, Design department and Assembly department. In each and every department have a well-trained person to handle issues while they work? Tecnimoplás holds fundamental values such as Honesty, Accuracy and sense of responsibility and all of these are the company mission and vision, company recognizes and appreciates the respect and ethics in human relationship and activities, sprit of team work. Our vision is to provide a good quality moulds for the clients and the mission is to satisfy the customer's needs. Be competitive in the moulding industry provided better customer satisfaction and also belongs to the main market and be the reference supplier in our market, thus provided continuous improvement of Tecnimoplás organization. Around 80 employees are working in Tecnimoplás.



Figure 1 – Overview of the main production unit

In this chapter contains, little overview about my internship programme and Small introduction about the hosting institution (Tecnimoplás). In further chapter, there is a detail explanation about my hosting institution including the vision, mission and strategic objectives.

2. About Tecnimoplás

In this chapter it will be described the institution where my internship took place. It contains the company characterisation, overall history about the Tecnimoplás and strategic objectives of Tecnimoplás.

2.1. Framework

The Portuguese moulds sector has around 684 companies with a PME dimension and dedicated to the design, development and manufacture of moulds and special tools; and employs about 8968 workers. Portugal is one of the world's leading mould producers and is currently exported more than 90% of the total production. Tecnimoplás is thus included in a sector where competition is high in Portugal, but also competition from more developed countries such as Germany, France, Spain, The United States, Canada and emerging China and the eastern European countries. Currently, Tecnimoplás focuses its offer on a set of solutions in the development, Manufacture and testing of injection moulds for plastics, which can be up to 20 tons with simple or complex movements such as sandwich moulds, Multi-component moulds and moulds for assisted injection gas mainly for the automotive market, but also for the packaging electrical/electronic markets.

2.2. Company Characterization

The Tecnimoplás – Industry Technical moulds Ltd is an SME with the economic activity classification, in accordance with the provisions of degree no: 381/2007 of 14 November, CAE: 25734 - metal mould manufacturing based in Marinha Grande with a registered capital of 1,000,000.00 €, its corporate object being the design and manufacture of metallic moulds.

2.2.1. Location

The industrial plant is in the industrial zone it is called as Marinha Pequena Industrial Area, according to the master plan with address in the Leiria road, Apartado 107, Marinha Grande.



Figure 2 – Company Outlook

2.3. Brief History of Tecnimoplás

The company was founded on 1971 in Figueira da Foz, in the production of steel moulds for the plastics injection industry with a capital share of 600,000 €, divided by 6 partners.

At the end of 1974, only three partners were members of the company with equal interests amounting to 600 contos (about 3000€). In 1973 the headquarters of the company was changed from Figueira da Foz to Marinha Grande, where it starts to work in leased facilities. In 1976, already in Marinha Grande there is 18 employees. Tecnimoplás carries out the first direct export, namely a mold for a Wringer for a client from the United States of America.

In 1981, the company acquired the land where it builds the current facilities in Marinha Grande, leaving the company as of 1985 it belongs only to two partners. The land where the industrial establishment is with an area of $9565.50 m^2$ is bordered to the north by EN 242, but there is no direct access to that road infrastructure, the bridge with the street of the metallurgical industry, a municipal street that guarantees to access the company. These installations located in an Industrial Zone called the Industrial Area of Marinha Pequena.

In 2007, the two partners retired, passing the management of Tecnimoplás to their children, assuming itself as a success case in the succession of industrial family companies in the sector.

In December 2015, the capital share of the company was changed to fit a renewed strategy of broad management of the value chain, with the founding partners having a share of 5% each and their children with an equal share.

Currently, there are 75 workers in our company with an increase of 2 workers from 2016 – 2017, of which 15% are young graduates in the area of industrial production – IPL Leiria, Mold production – ISDOM Marinha Grande and other degrees.

During its 47 years' experience Tecnimoplás was a pointer in the adoption of several technologies, it is worth mentioning that it was the first company to have a deep hole drilling center (1988), the first to exploit EDM technologies (1973) and CAD/CAM (1986). Also, at the product level was responsible for innovations where stands out one of the first sandwich molds at the national level, produce in 1984.

The continuous commitment to modernization quality and innovation resulted in the submission of two SI qualification and Internationalization and SME innovation project in QREN, characterized by innovation in the company's processes, to obtain significant improvement in its performance and thus increase productivity. Another milestone in the company's life was the certification by NP ISO 9001:2008 in October 2010.

2.4. Vision, Mission and Strategic Objectives

The definition of business strategy formally expressed by the company, based on a clear and objective relationship between vision, mission objective strategy and values, serving as guidance and guidance for all stakeholders.

2.4.1. Vision

The Tecnimoplás vision over the next 10 years, enhance its reputation as a manufacturer of molds and product development of integrated solutions based on innovation reaching the TOP 15 companies in the sector of E & T at national level and strengthen their level of recognized at international level.

2.4.2. Mission

It is to provide customers with high quality complementary products and services, participating in the development and success of their business through the provision of all our know-how. They want to share success with employees and partners and ensure the company's partners a regular and high return on their investment.

2.4.3. Strategic Objectives

The Strategic Objectives defined reflect a strategic orientation directed towards exports, diversifying the client portfolio both geographically and at sectoral level, increasing the international competitiveness of the company, namely through product innovation with a view to sustainability and growth of the company.

2.5. Market with Customer

The Tecnimoplás is a mold making company, which exports more than 90% of its production, and the critical competitiveness areas as follows:

2.5.1. Project

Fundamental area in the development of engineering solutions that allow to design products and tools differentiating and aggregating added value.

2.5.2. Production (Machining, Drilling, Erosion and Assembly)

Fundamental area, comprising the technologies necessary for the manufacture of moulds, being their fundamental performance, as well as the work done downstream, in the areas of finishing and assembly.

2.5.3. Commercial

The company has a good knowledge of the markets, but the strategic objectives of the company, increasingly demand more dynamism in this area, namely in the field of communication and market prospecting.

The Tecnimoplás favors direct sales, and their client's injection molding companies, exporting about 90% of its production, mainly for the Automotive– 64%, Home products – 27%, and Glass products – 9%. Mainly Tecnimoplás were concentrated with the automotive mold, because now-a-days the main requirement is automotive. And also, there is a lot of automotive companies are there in the world, so Tecnimoplás mainly focusing in the automotive field. But they concentrate with the other fields such as Home products (Plastic Trays) and Glass products (Wine Glasses). These are the main partition of the Tecnimoplás production rate, percentage values are shown below in Figure 3

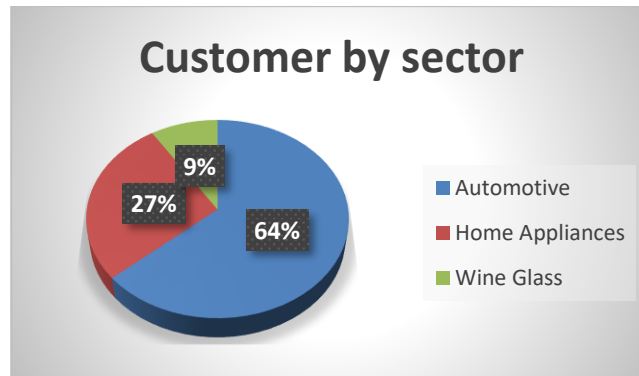

Figure 3 – Tecnimoplás customer by sector

The solutions are indicated to produce parts and components with very demanding aesthetic requirement, high precision and rigor dimensions, destined to markets and critical customers, where these molds are subject to aggressive operating conditions and pushed to the limit. In terms of customers, the company sells to large brands such as BMW, AUDI, and MERCEDES among others. In terms of geographical markets, there is a slight variation in recent years with Germany, Israel and the Czech Republic accounting for the most representative figures with the decrease in Switzerland.

The cost estimation for the molds in Tecnimoplás (as shown in Table 1). Always the cost can differ with the size of the molds. Usually in Tecnimoplás produce the three kind of molds such as Large size mold, Medium size mold and Small size mold. But some time the cost getting high compare to this table, because normally they made in this size (for example: if they are going to make a small mold with the lots of complications inside the molds means at that time the cost getting high).

Size of molds	Cost €
Large	250000
Medium	100000 – 150000
Small	30000 – 50000

Table 1 – Cost estimation for different size of moulds

There are some main customers in automotive field on the Tecnimoplás, such as (Audi, BMW, Mercedes Benz, VW, Mini Cooper, Peugeot). For the Tecnimoplás most the customers from Germany (Audi, BMW, Benz, VW), because main automotive manufacturer is there in Germany. And they have a some other few customers from other countries such as UK (Mini Cooper) and France (Peugeot). Out of 100% almost 85 % of customers from Germany, 10% from UK and 5% from France. The values are shown below in Figure 4

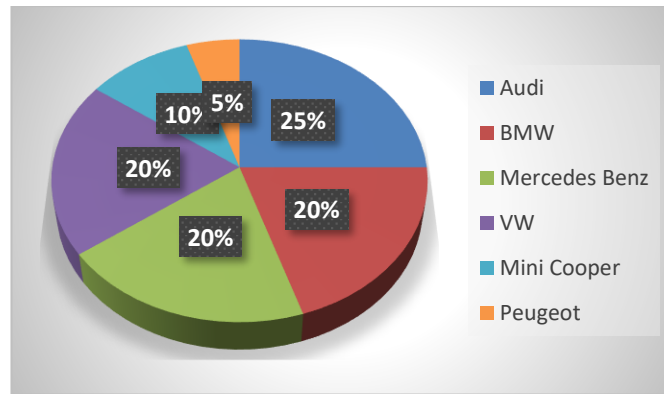

Figure 4 – Main Customer in Automotive field

This graphical view is to indicate the Volume of business in Tecnimoplás per every year. It depends upon the size of the mould they manufacture, usually Tecnimoplás concentrating to manufacture a Large mould that is the reason to increase the volume of business. The detailed explanation with discuss below, and graphical view shown the deviation of Business volume (Figure 5)

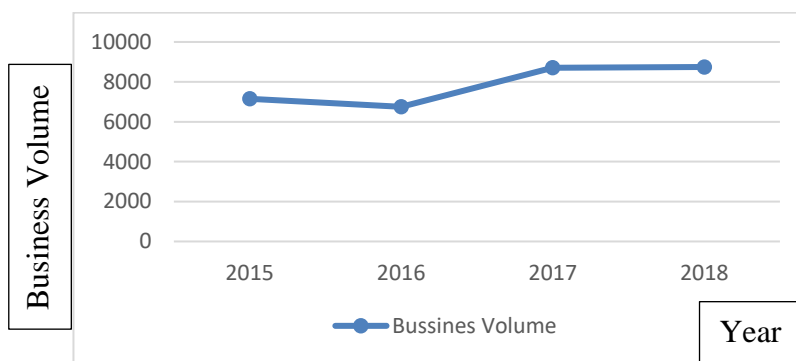

Figure 5 – Business Volume per year

In Tecnimoplás they produce three different size of moulds such as Large, Medium and Small. Mainly Tecnimoplás are focusing with the large size of moulds in Automotive field. In 2016, totally they produce 32 moulds with different size (17-Large moulds, 10-Medium moulds, 5-Small moulds). These are production rate in year of 2016. In 2017, totally they produce 37 moulds with different sizes (19-Large moulds,10-Medium moulds,8-Small moulds). In 2018, totally they produce 48 moulds (20-Large moulds, 16- Medium moulds, 12-small moulds). These are production rate in Tecnimoplás for Last three years. If you compare with 2016 and 2018 production rate means there is a deviation (shown in the Figure 6), because Tecnimoplás concentrating in the complex moulds.

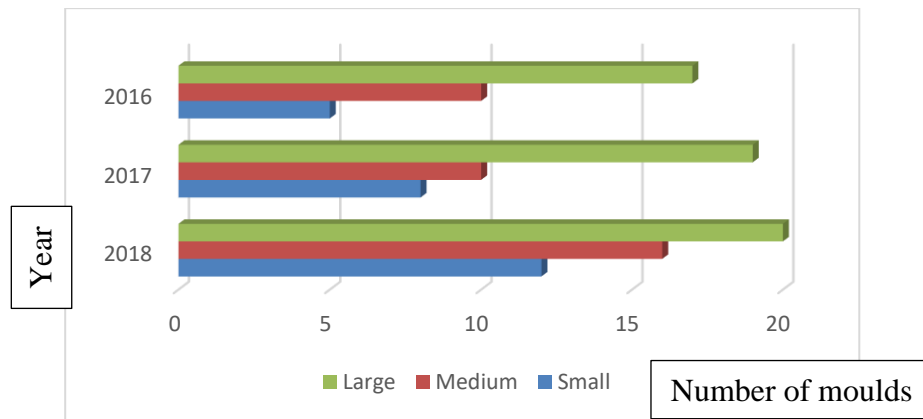

Figure 6 – Number of moulds manufacturing per year

The Tecnimoplás manufactures molds with very tight technical requirement with high quality for very demanding industries. Given the competitive advantage that has Tecnimoplás face to most of its competitors, as well as through those that it intends to develop, the company presents itself to the market based on factors of differentiation namely: Quality, Technical rigor, Term and Extended value chain. The knowledge developed by the company's R & D center and the market inputs received from customers led the company and re-equated its product offering.



Figure 7 – Samag (3-1500) Outlook view

As explained above in volume of business topic, Tecnimoplás focusing to manufacture a large mold, to increase the production of large mold they are planning to buy a large machine such as SAMAG. In this machine there is plenty of options do to the different kinds of operation such as large inclination holes for the water and oil circuit (+30° to -30°) and long gun drills (up to 1800 mm). This machine is the one of the most important machines in Tecnimoplás to increase the large mold production. All technical information about this machine on shown below in Table:2.

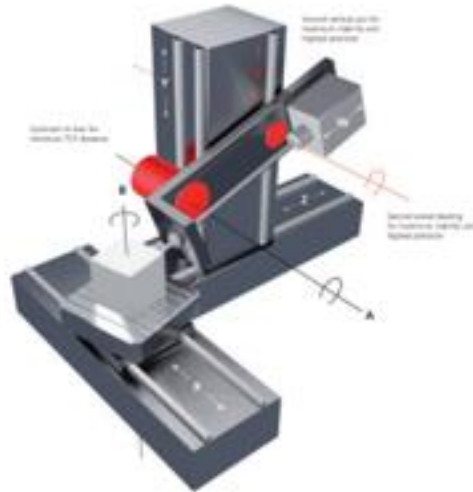

Figure 8 – Working methodology of Samag (3-1500)

Technical Data	Units
X-axis maximum	2000 mm
Y-axis maximum	1250 mm
Z-axis maximum	1250 mm
W-axis maximum	2250 mm
A-axis maximum	± 30°
B-axis maximum	360°
Table area	1800 × 1800 mm
Maximum table load capacity	20000 kg
Maximum coolant Pressure	90 bars
Maximum coolant Flowrate	90 L/min
Fixed tool inside the machine	32
Spindle Power	17/25 KW
Spindle Speed	6000 rpm
Spindle Torque	216/320 Nm
Process	Milling Deep hole drilling
Software	Heidenhain

Table 2 – Technical Information about Samag (3-1500)

Deep analysis of this machine is it has a high spindle speed and large working space when compare to the other types of deep hole drilling machines, for example (HETO-2500 master) detailed technical information about this machine is explained in following topics.

And also, Samag have a more benefits like improved cooling and air conditioning concept, it has a direct measuring system in all main axis. And one more main advantage is quick change setting for set-up preparations while during the drilling production time. That is why Tecnimoplás like to use this machine, because they are concentrating with a large mould. This machine is properly fixed with this condition.

In this chapter, there is a detailed explanation about the Tecnimoplás including, brief history about Tecnimoplás and their strategies like “who are all the main customers” and “how much they cost for the mould”. And it has a technical information about the Samag, because they contracting to create a large injection mould. In future topics are belong to the Plastic injection moulding and its history.

3. About Injection Plastic Industries

This chapter contains a brief explanation about the Injection moulding process, Industrial glass mould revolution and about the plastic industries.

3.1. Injection Moulding

Injection moulding is a technique of making an object and producing the object by injecting molten raw material. The raw material is directly injected into the Cavity; it will be manufacture according to the shape of the product. Thereby, the product of the desired shape and material is moulded by injection moulding. In the injection moulding the polymer is heated to a highly plastic state and forced to go into a mould cavity under high pressure, where it solidifies. And then the object is removed from the cavity. This process creates some unique elements. Also, there are many cavity moulds that can be used to create multiple parts in one cycle. Main motive is to produce of moulds. The cost is very important when designed a mould.

3.2. Industrial Revolution in Glass moulds

Glass production industry is a one of the main productions in England for Nearly fourth centuries. There are three main department based on the type of glass production: Windows, Tableware and Bottles. The origin of English bottles is uncertain and even contested in the 17th century. English bottles were clearly existence in the middle of the 17th century [26]. A large number of bottles are made and progressive changes in their form have been used by archaeologist to store the archaeologist deposits they have been found. The earliest bottles were mouth blown, perhaps it made without the help of moulds [40]. The shaping of the glass usually took place at several different stages. The first step is to collect sufficient glass from the furnace at the end of blowing iron. The glass was enlarging to create an oval shape. The oval shape was designed by rolling it on the smooth stone table. And then the oval shape glass is reheated in the oven to produce it into the soft enough surface and also to produce it into required shape [15]. They can further adjust the shape by stretching the glass or rolling it into the smooth stone and for adjust the shape they use the pincers and some other tools. Previously bottles have a universal body with a long neck, the bottom of the bottle was

pushed down to provide a stable base on which the bottle can stand [37]. In later 17th century the bottles were given by short necks and body.

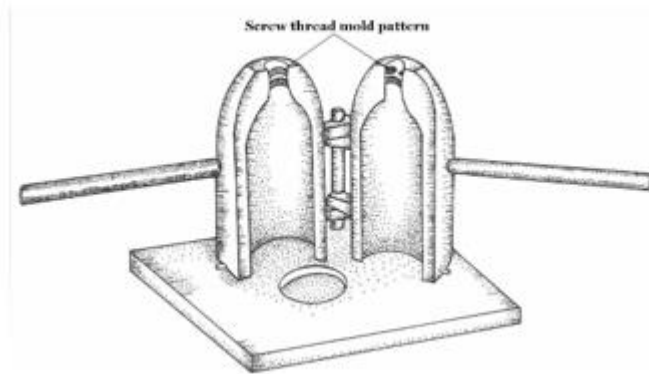

Figure 9 – Traditional methodology for Glass mould

In early 18th century saw the appearance of the short cylindrical bodies, which were certainly made it with the molds. These kinds of molds are simple open cylinder; instead the glass was introduced, blow to fill material to the molds and then it opens vertically. Some bottles of the 18th century with a cylindrical body but slightly wider shoulder was certainly made in such a mold. After the invention for a Bristol glass house indicate that a Brass and Iron bottle molds were, they introduced that on 1970s. Dip molds continues to the manufacturing cylindrical bottles until the middle of the 19th century [36]. In the later period of 18th century the cylindrical bottles were made taller. The creation of the taller bodies may have been aided by the use of hinged two-part molds; However, the earliest illustration of such a mold is 1849 [2].

Henry Ricketts received a patent in 1821 to produce a three-piece mold, which allowed to shape the neck, shoulder and body of the bottles. Ricketts mold allowed to manufacture a bottle with a uniform size, although the capacity was slightly difference as the glass was still collected by hand. Ricketts molds can be used to insert the words and letters into the bottle; many 19th century bottles were made with the letters, which is usually refer to the content of the bottle. The “Finish” (Rim) still is a handmade part, however the late of 19th century a special pair of tongs was developed which allowed to be shaping the proper design for the bottle.

In Second half of 19th century a variety of patents were issued to manufacture a bottle with both molds and compressed air [34]. The most famous of these patents were awarded

to Howard Ashley in 1880s for a press and blow machine. Still the glass was collected by the hand and also placed in simple hinged mold. The plunger was used to create a neck by pressing the glass, and then the plunger was removed and compressed air are used to inflate the glass, finally produce the body, the use of this machine allowed a single worker to produce 1560 bottles in a same time, while a traditional group of four can produce 720 bottles [11]. Michael Owens invented an automatic machine in the last decade of the 19th century, that machine can do both collect the glass and made it into a bottle. In this machine had a series of Arms each with a parison and finished molds. As the machine is rotated each hand dipped in to the molten glass and the vacuum absorber is used to collect the necessary glass. The machine was rotated to allow the next hand to collect the glass, after collecting the glass material first arm is inflated using the compressed air to create a bottle [10]. These machines are widely used in the middle of 20th century, although broadly similar machines were developed (often smaller and cheaper).

3.3. Brief Overview of Plastic Industries

It is best to understand the professionalism covered by molding industries for plastics. Plastics is present in our everyday life in various categories like in Home (television sets, toys, computers, containers for food and kitchen utensils), in Cars (dashboards, stirring wheel, bumpers, etc.), in Hospitals and Health centers (syringes and blood bags), in Protection and Safety devices (goggles, helmets, graves), in food packing (film and plastic bags to preserve it long). So, the man is completely surrounded by materials made up of plastics.

This is the first chemical substitute for the development of chemical industry to provide by second industrial revolution, until the 19th century. It will give birth to the semi- synthetic plastic such as vulcanite, Parke sine, celluloid and celluloid acetate [5]. Then these products are used to replace certain products to produce objects like smoking pipe stem, pins, match boxes, pens, toys, knife handles etc. The first complete synthetic plastics was formed in 1937, it was developed by Leo Baekeland and commercialized under the name of Bakelite. The new material has more features like highly insulating property and is easily designed, it will be allowed to successfully be used in electrical, telecommunication, automobile and radio industries [19]. However, no matter what method to choose, but plastic production is usually three stages:

- Heating (to melt the plastic);
- Molding (design the final product);
- Cooling (sort the desired shape).

Plastic material and its technologies equipment due to the evolution of its special material such as wood, ceramics, glass, and metals are gradually changed. Following its development, the molding technology is temporarily adapted to respond to rising the claims from the plastic industry. Outline of the injection process of plastics parts [12]:

- Feeding the raw material (plastics) to the injector;
- Heating a raw material to soften it;
- Injecting the raw material into the mold;
- Extracting the end part.

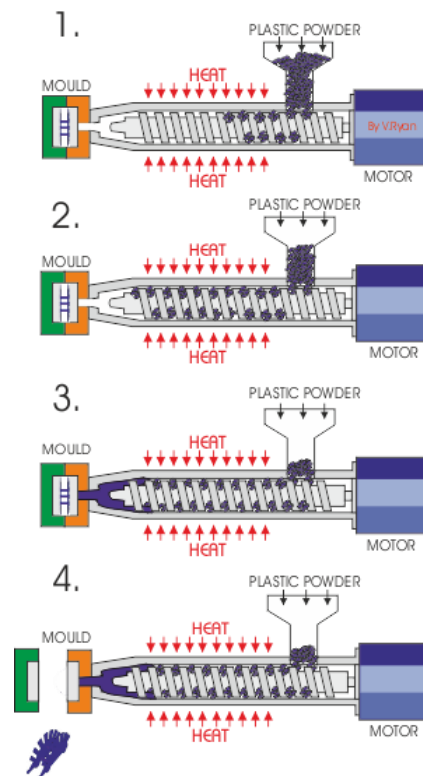

Figure 10 – Process for Injecting plastic [14]

3.3.1. First molds for Plastic Injection method

Since the making of first injection molds (late 1940s, early 1950s) until the introduction of computer technology in the mold making process (early 1980s), Production of plastic pieces using the injection process usually requires more complex molds that are made of steel to withstand high pressures and temperatures. The first injection molds made in

Portugal were essentially intended for toys, religious figures (saint), and household goods (buckets, bowls etc.). Nevertheless, this phase is not determined by these technologies because at the outset of the exports more pressure was needed to buy new and modern equipment, to answer the rising demand for high degree with plastic pieces. From this movement on there will be mold making for two major groups of plastic pieces: toys (Cars, Airplanes, Boats, Animals, Soldiers, and Dolls among others) and household and decorative items (Tableware, Mirror, Frames, Pots, Sugar bowls, Butter dishes, Trays, Plastic flowers among others). Therefore, among others some of the most important tools are: Pantographs, Precision milling machines, Vertical Grinding machines, Lathes, Lathes for High precision and Shaping [3].

The word associated with this equipment is increasing the need for precise energies and higher mold dimensional accuracy was growing. To meet the need for accuracy, it is important to introduce new devices, especially the milling machines, which allow certain tasks such as steel grinding, which could not be previously done. The will to satisfy the technical demands of these new foreign clients, would have led Mr. Abrantes to purchase, in 1958 “a spark erosion machine that had to be returned because no one was able to operate it [18]. However, it is not enough to achieve the desired perfection to use new devices; because project designer’s work is increasing, they are drawn with the precision drawing. These machines, Mechanical Steel works have been permitted by the use of copper and graphite (electrodes) tools, which are impossible when approaching draft technologies. The process of milling steel using corrosion method is made using steel melt countless and continuous electric discharges, making it to acquire the intended shapes. The introduction of this technology was designed, especially in the machine scales of some of the most complex forms, to reducing the timing of the work and improve the molds and its quality.

3.4. Overview of Injection Molding process

The most commonly used manufacturing process for fabrication of plastic parts is injection molding method. A variety of products are made using Injection molding, which vary greatly in their size, complexity and its applications. In the process of injection molding requires the use of injection molding machinery, Raw material (Molten Plastics) and a mold. The plastic is melted in the injection molding machine and then injected into the mold, where it cools and solidifies into the final parts. In injection molding is mainly used to make a thin-

walled plastic parts, in thin walled parts have a different shape like a cylindrical, cube and complex [23].

3.4.1. Molding Process

The injection process is very short time, usually between 2 seconds to 2 minutes with the following 4 stages,

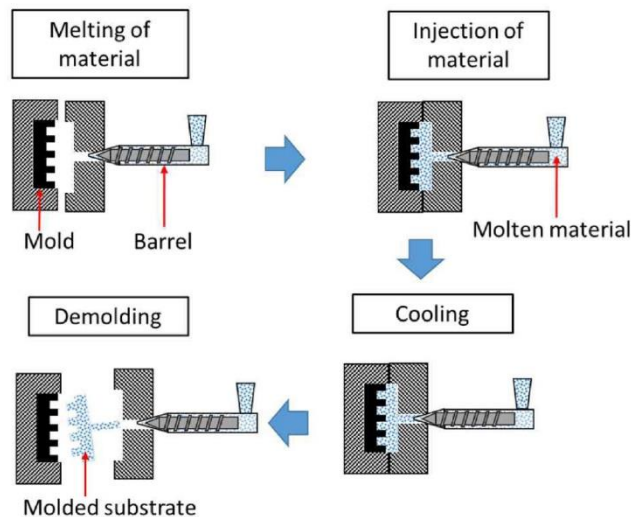

Figure 11 – Main 4 stages of Injection moulding process [27]

- Clamping unit:** Before injecting the plastic into the mould, both parts of the mould must first be securely covered by the clamping unit. And both half of the mould is connected with the injection machine and allows one half to be slide. Usually the hydraulic clamping unit pushes the mould parts together and exerts enough force to safely close the moulds when the material is injected. The time required to fix the moulds is depending on the machine – if its larger machine (those with higher clamping powers) will need more time. This time can be estimated from the dry cycle time of the machine.
- Injection unit:** The Raw material, usually in the form of pellets, is injected into the injection machine and progresses to the mould through the injection unit. During this process, the plastic material is melted by high heat and pressure. After that the plastic material is injected to the mould with quick movement and creates pressure packs and hold the material. The amount of injected material is referred as the word “Shot”. Due to the complex and dynamic flow of molten plastic, it is very difficult to calculate accurately the injection time. Moreover, the injection time can be calculated by shot size, needle pressure and needle force [23].

- Cooling unit:** The molten plastic inside the moulds begins to cool, once it comes in contact with inner mould surfaces. When the plastic cools, it will solidify into the desired area. Moreover, there may be some contraction of the area during cooling. Packing of the material in the infusion phase allows the extra material to flow into the mould and reduce the amount of visible compression. The mould cannot be opened until the required cooling time has passed. The cooling time can be calculated from the many thermodynamic properties of the plastic and the maximum wall thickness of the area.
- Ejection unit:** The ejection system in moulding process to push the final part of the mould. They are often used for forcing a solid part out of the mould and they are usually made up of high-quality steel. When the mould opening is complete, the injection machine thick ejector is pushed to the plate. The ejector plate moves forward to guide to moving the ejector guide pin. Ejector pins are tied between the two-ejector plate, so it can be move forward and help to take out the final product of the mould. After we get the product, the needle will move behind the rod. The return pin spring moves behind the ejector plate. The spring and mould closure guide ejector back into the position.

3.5. Moulds for Injection of Plastic

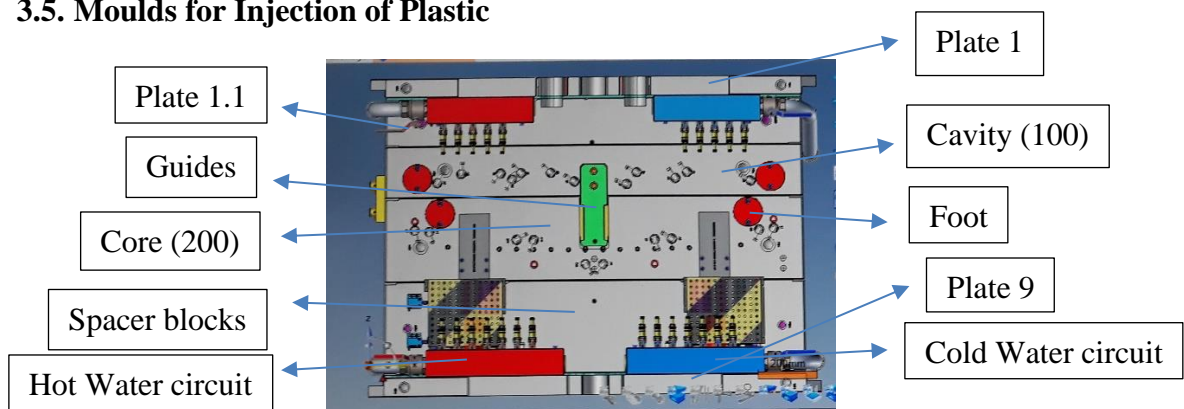

Figure 12 – Injection Mould plastic

A mould is a container prototype, which aims to produce an object with a specific format. There are several categories within the area of mould depend upon the designing technology or raw materials used. The first step in the moulds depending on the injection, pressure, transition, blow technology, thermoforming and circulation. The second step in the moulds thermoplastic, thermoset, rubber, glass and light alloys are classified. A simple steel moulds are thermoplastic injection/plastics consists of two parts: one is the female part (the

cavity) and other is the male part (the core) both the parts are fits together. Once if both the parts are fitted together there is a space to be given for an accurate thickness in which the fluid (raw material) is injected to the mould. moulds are also produced for various industries with different levels depends on the complexity.

Now-a-days in the mould industries can produce the moulds from automobile to agriculture. However, a personalized mould is not a highly customized tool because serving solely to produce pieces in this case its small or large series for which it was designed. Each mould affects the various construction requirement directly and also it affects the delivery time and cost of the mould. However, it requires a package of geometric and dimensional conditions that require efficient and precise equipment.

3.5.1. Types of moulds

- **Two plates Moulds:** The Two-plate moulds have a simpler injection system and it has a more advantages. There are two different sides in this type of moulding (A-side & B-side). When this mould is mounded on the injection machine to make part at that time A-side is fixed and B-side is a Movable side [24]. (A-side is a Cavity and B-side is a Core side). Some of the tools are used in two plate moulds are (Locating ring, Guide pin, Return pin, Ejector Guide pin, Support Pillar, Spruce bushing).

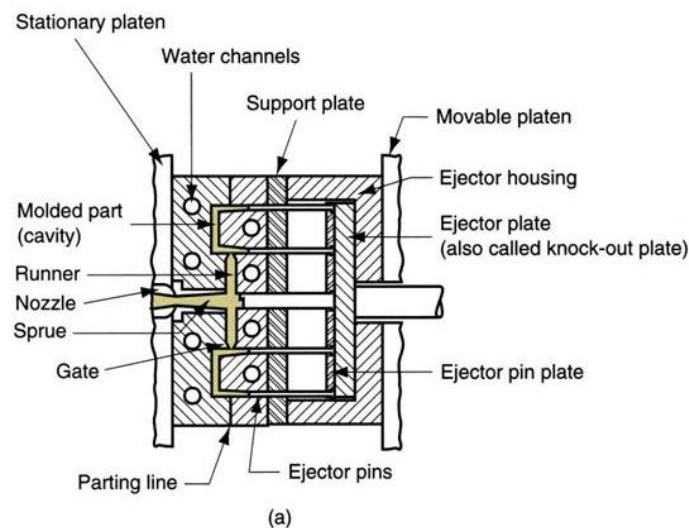

Figure 13 – Two Plate Mould [13]

- **Three plates Moulds:** Three-plate mould is also known as the Small gate mould and one of the differences is additional mould plate is required between Top-clamp plate and Cavity plate, which is called as a Runner plate, it allows the runner scrap and

plastic moulded parts separately. In this type of mould, the plastic particles are injected through the runner and a Gate, this will make easier to remove from the gate area and it gives a finished part. Usually there is a supply channel on the moulds on which the polymer melts into the mould cavity from the tip of the Needle barrel. In that channel consists of Sprue, Runners and Gates [25].

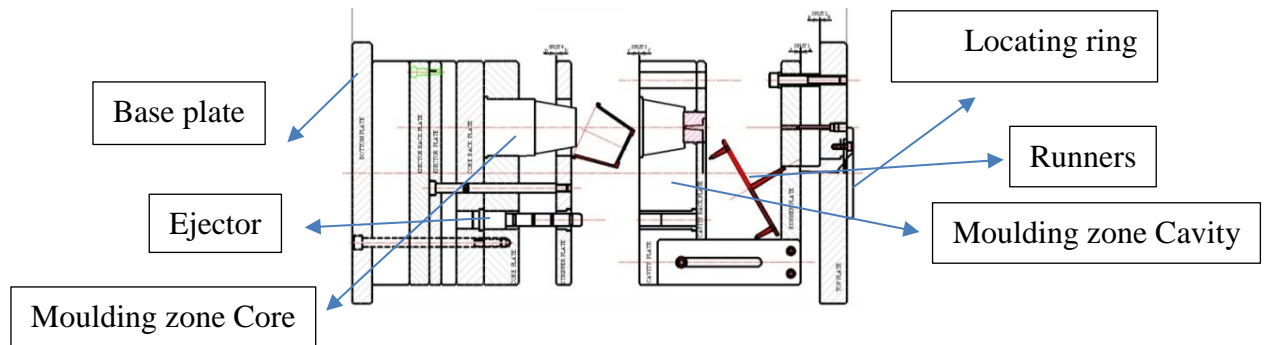

Figure 14 – Three Plate Mould [21]

- **Stack Moulds:** The stack moulds have a two mould parting surfaces or mould split lines. The stack mould does not require more clamp power than a single-phase mould, because the projected surface area of the cavities on both sides of the centre block cancels the force on each other. The rule of thumb for a clamp force assessment is to take the projected surface area into the melt pressure and multiply it by a factor. Some layered stark moulds have different cavities on each mould splitting surface, and they form a family of parts per shot, each mould varying in shape and size. Some stack moulds can handle different material such as multi-material injections, hard/soft combinations or multi-colour moulding.

3.6. Mould Components and how it works

This is one of the main chapters to know about the mould components and its working, for example, to know how the mould can work in detail manner. The list of mould components is explained below [9]:

- Mould Base;
- Mould Cavity;
- Mould Core;
- Runner System;
- Gates & Vents;
- Cooling system;

- Ejection system.

In the whole mould have a different type of plates are fixed (Ejection half (200), Injection half (100), Spacer blocks (5,5.1,6,6.1), Ejector clamping plate (7, 8 and 9), Injection ring holder plate (1) and Runners holding plate (1.1). Each and every plate are explained below in detail manner.

Movable Half : 3 or 3+200, 5, 5.1, 6, 6.1, 7, 8, 9

Stationary Half : 2 or 2+100, 1, 1.1

3.6.1. Movable Half (Ejection Half)

A core is a device used in Casting and Moulding processes to produce the internal cavities with the proper angles. Core insert will have projection and will create hollow portion in plastic component. Core plate usually made up of mild steel material and P20 directly use without hardening after core machining. In Ejection side it has a different stage of plates,

PLATE NO: 200, 5, 7, 8, and 9

These kind of molding blocks are very difficult to manufacture, because in the molding zone there is a lot of works to create an extraction part. Main thing is, it takes a more time to create. As explained above Tecnimoplás always willing to create a complex and large mold.

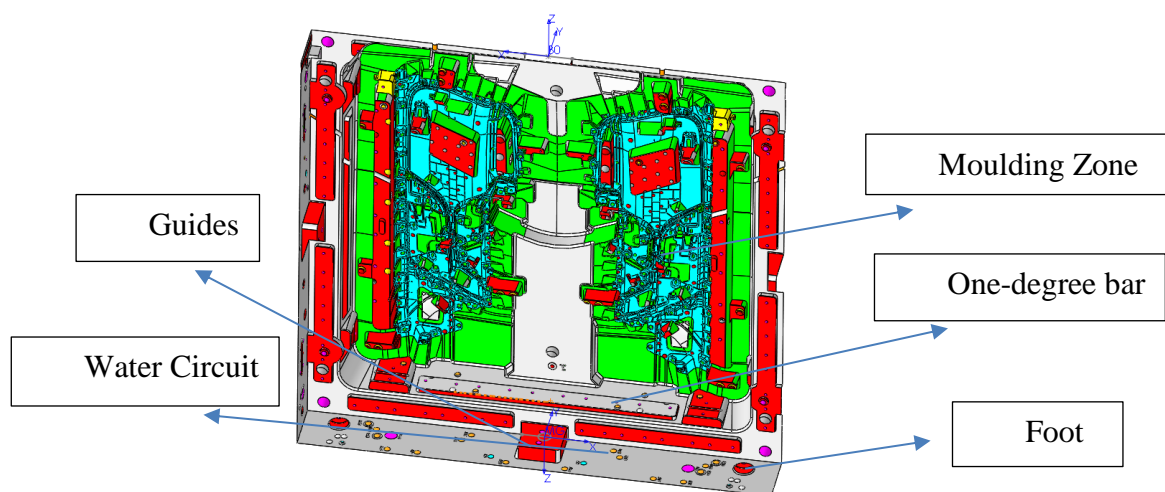

Figure 15 – Movable Half (Core)

Moulding Zone: This is the main zone in the moulding parts, because it can hold the plastic part and create an exact plastic part, that what they need.

One-degree Bar: One-degree bar is mainly used to reduce the friction between the Injection and Ejection plate while they close the moulds for the injection process.

Foot: While they put moulds in vertical position, it helps to hold the mould.

Guides: This is type of tool is used to fix the mould without any movement, while they inject the plastic.

Water Circuit: Its mainly is used to cool down the plastic part, while they ejected. But sometimes in this circuit they use cold water and hot water depends upon the condition of the mould parts.

3.6.2. Spacer Blocks with ejection side base plate

Spacer blocks are used to create a space between the movable clamping plate and the movable tray allows the ejector plate to move, when the area is evacuated. And it has some space for the ejector pins.

Spacer blocks (5, 5.1, 6, 6.1): These blocks are usually to hold the ejector plates and ejector pins. In between the gap of plate, no:9 and the spacer blocks is used to fix the plates.

Ejector Pin Gap: It helps to move the ejector pin through the movable half (Core) with the forward and backward movement.

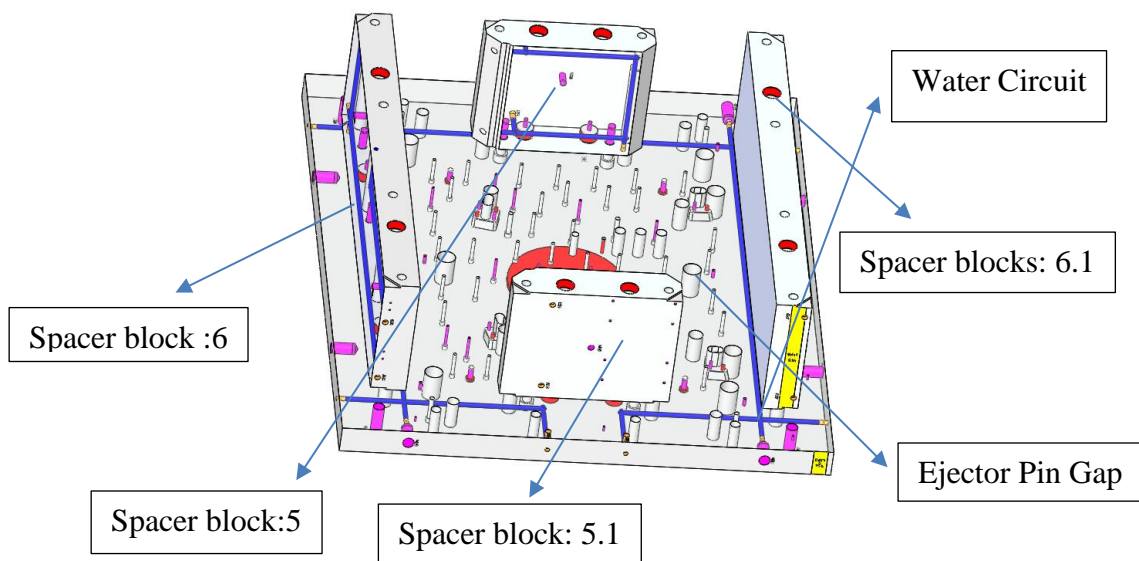

Figure 16 – Spacer Blocks with Ejector base plate

3.6.3. Ejector Retainer clamping plate

In this plate is mainly used to holds the ejector pin, Runners and circular guide. When the mould is closed the ejector, unit is back in its original position with the help of Circular guide.

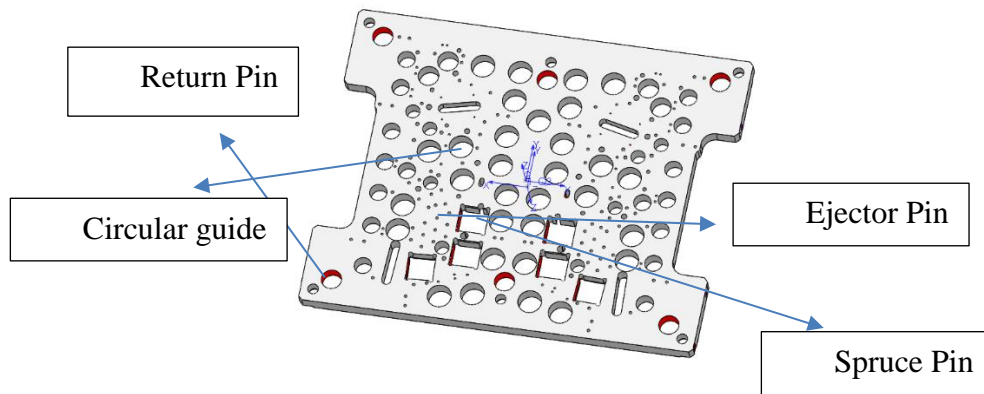

Figure 17 – Ejector Retainer clamping plate

Circular Guide: This guide needs to be in H7 format, because to avoid the friction with the circular guide and plate. This type of guides is mainly used to give a up and down movement, while the mould is injecting and ejecting time and also to guide the ejector plate.

Return Pin: Return pins are used to help ensure correct return of the ejector assembly to the home position.

Ejector Pin: These pins are located on the movable half and the area when the molds open. Once the mould is open, the pins are extended into the mould cavity, pushing the area out then retract up and allowing the moulds to close and refill.

Spruce Pin: It removes the material from the spruce bushing at the end of the molding cycle.

3.6.4. Ejector Clamping plate

Clamping plate is used to pushes the ejector pins and reverse pins simultaneously. The ejector was mounted to the retaining plate to create the ejector unit. Additionally, in this plate have a supporting bar placed between the spacer blocks to provide additional support for a movable tray.

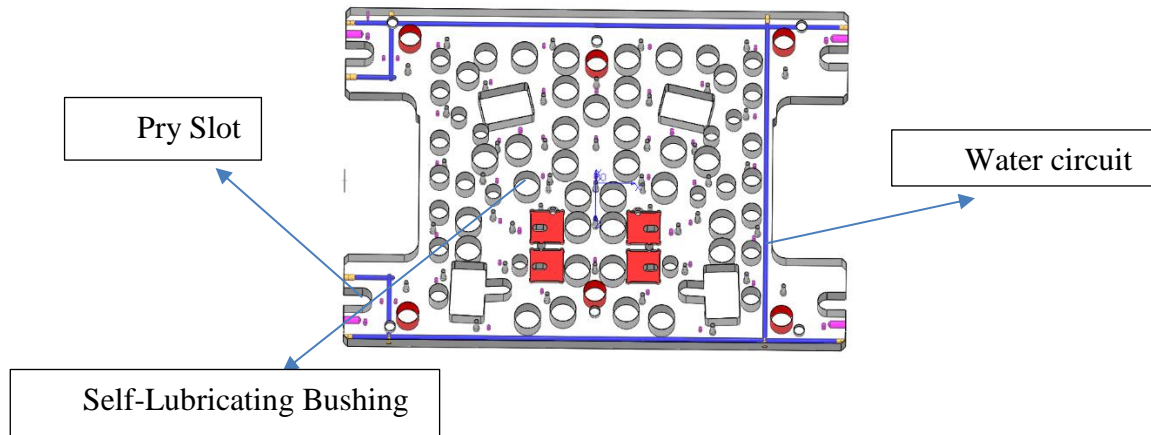

Figure 18 – Ejector clamping plate

Self-Lubricating Bushing: This Bushing is used for the guide pins, to save the time and money in the design, construction and the operation of injection moulds. These kinds of lubricants are suitable for all applications and also it prohibits the use of external lubricants.

Pry Slot: Located on the dividing line of the mould body to pry the mold body. This provides the handling easy, when opening and disassembling a mould.

3.6.5. Ejector Base plate

This plate is also called as a bottom plate, it is mainly used to withstand the spacer blocks and the ejector pin.

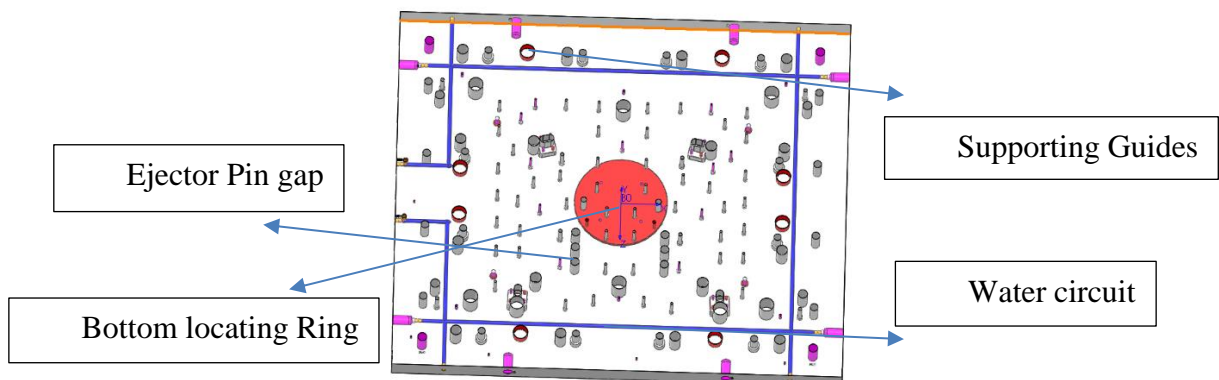

Figure 19 – Ejector Base plate

Plate No	Working
200	Moulding zone ejection side (To extract the plastic piece after plastic get injected).
5, 5.1, 6, 6.1	Spacer blocks (To create a space to fix the ejector plate and ejector rod).
7	Ejector Clamping plate (Its mainly used to fix the ejector needle)
8	Ejector Plate (conditions are same as the plate no:9)
9	Bottom plate (Its used to hold and fix the moulds in the injection machine)

Table 3 – Overview working of Movable half

3.6.6. Stationary Half (Injection side)

Cavity plate is used to fit with the insert, the cavity plate has a gap to fill the plastic material and form a plastic component. Cavity plate usually made up of Mild Steel Material and P20 directly use without hardening after cavity machining. In injection side it has a different stage of plates,

PLATE NO: 100, 1.1, and 1

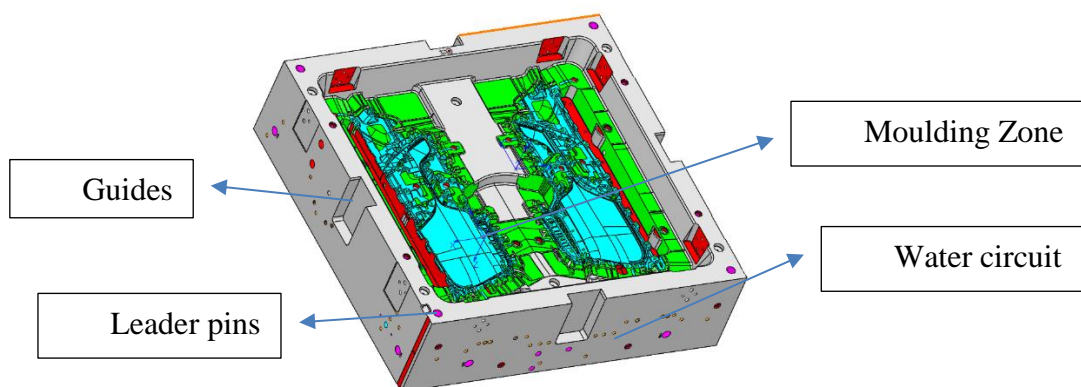

Figure 20 – Stationary Half (Injection half)

Moulding zone: This type of moulding zone is different from the movable halves, because in this half have a gap in the moulding zone. Main motive of this half is to create an exact shape of the plastic piece, because this is an injection side.

Guides: Usually in the moulds have 4 guides, in each and every side have a 1 - guide. But one of the guides are placed in the centre of the mold, it just dislocated from the centre of the mould, to prevent the dislocation of the moulds while it close.

Leader pin: Its available in the both half's (Movable and Standard half), main usage of this pin is to align the both halves of the mold at the parting line.

3.6.7. Base plate in Stationary half

In this plate have a locating ring to locate the centre of the injection machine with a sprue bushing and the tip are aligned. There is a narrow hole through which the material is forced into the runner. It is cut against the tip of the needle.

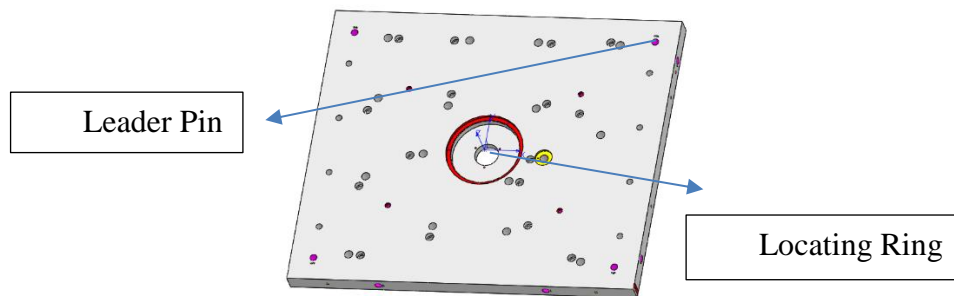

Figure 21 – Base plate in stationary Half

Locating Ring: Locating ring is placed in the base plate in the Stationary half. And also, this is a main part in the injection moulding, its helps to inject the plastic raw material into the mould with the help of Injection machine. If one injection process is finished that's also called as a one shot.

3.6.8. Clamping plate for the Hot and Cold Runners circuit

In this plate has several gaps inside the plate, the gaps are used for to fix the Hot and Cold runner system inside the moulds.

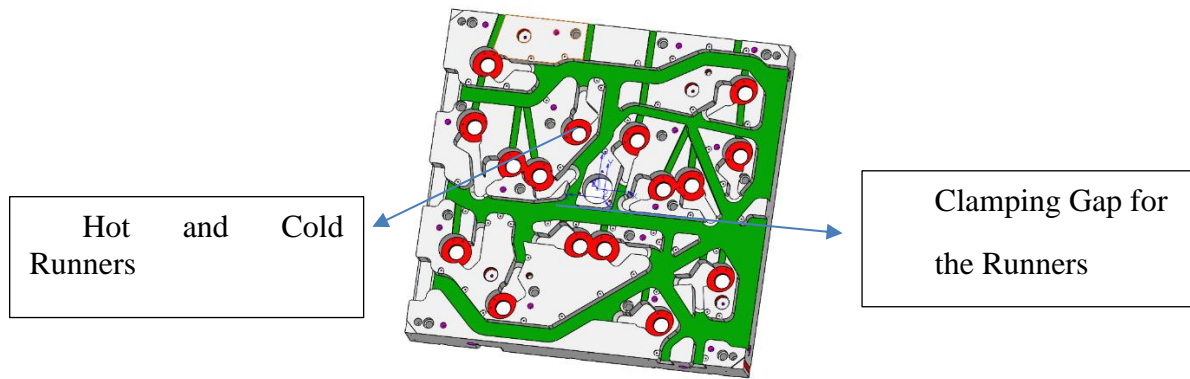

Figure 22 – Clamping plate for Runners

Hot Runners: In a hot runner system, a multilayer system heats the moulds and sends the molten plastic to every end, providing the plastic to the various pits within the mould. This type of runners can be heated internally or externally [30].

Cold Runners: In a cold runner system, plastic injection done through the spruce tool. The plastic fills the runner leading to the cavity.

Plate no	Working
100	Moulding zone injection side (To inject the plastic parts through the locating ring)
1	Clamping plate (To hold the locating ring in the bottom of the plate (Injection circle))
1.1	Clamping plate (To hold the Hot and cold Runners circuit)

Table 4 – Overview working of Stationary Half

The mold base is a set of steel blocks manufactured with specific dimensions, these dimensions are and can be found into all the mold-base manufactures. Mold sites can be bought from commercial mold base manufactures or produced by mold makers. Basic mold base is in two halves (A and B half). “A” half it is called the standard half (Injection side), and “B” half it is repeatedly referred to as the moving half (Ejection side). A mold Cavity that produces an external appearance or surface area of the mold is usually mounted on A half, while the mold Core that reproduces the inner look of the mold is usually attached to the B half of the mold. Collectively, the Cavity and Core parts are called as the ‘Mold Set’. Molding blocks (Cavity and Core) are usually made from special mold steel or some other materials like Beryllium, Copper, Stainless steel, Aluminum, Brass and other materials such

as epoxy. Softer mold materials are commonly used as the prototype molds and for limited product runs. All plastic products have their compact factor, which are compressed to cool and stabilize at a certain rate. Depending on the type of material to be injected, the producers should consider its shrink factor when creating the cavity set.

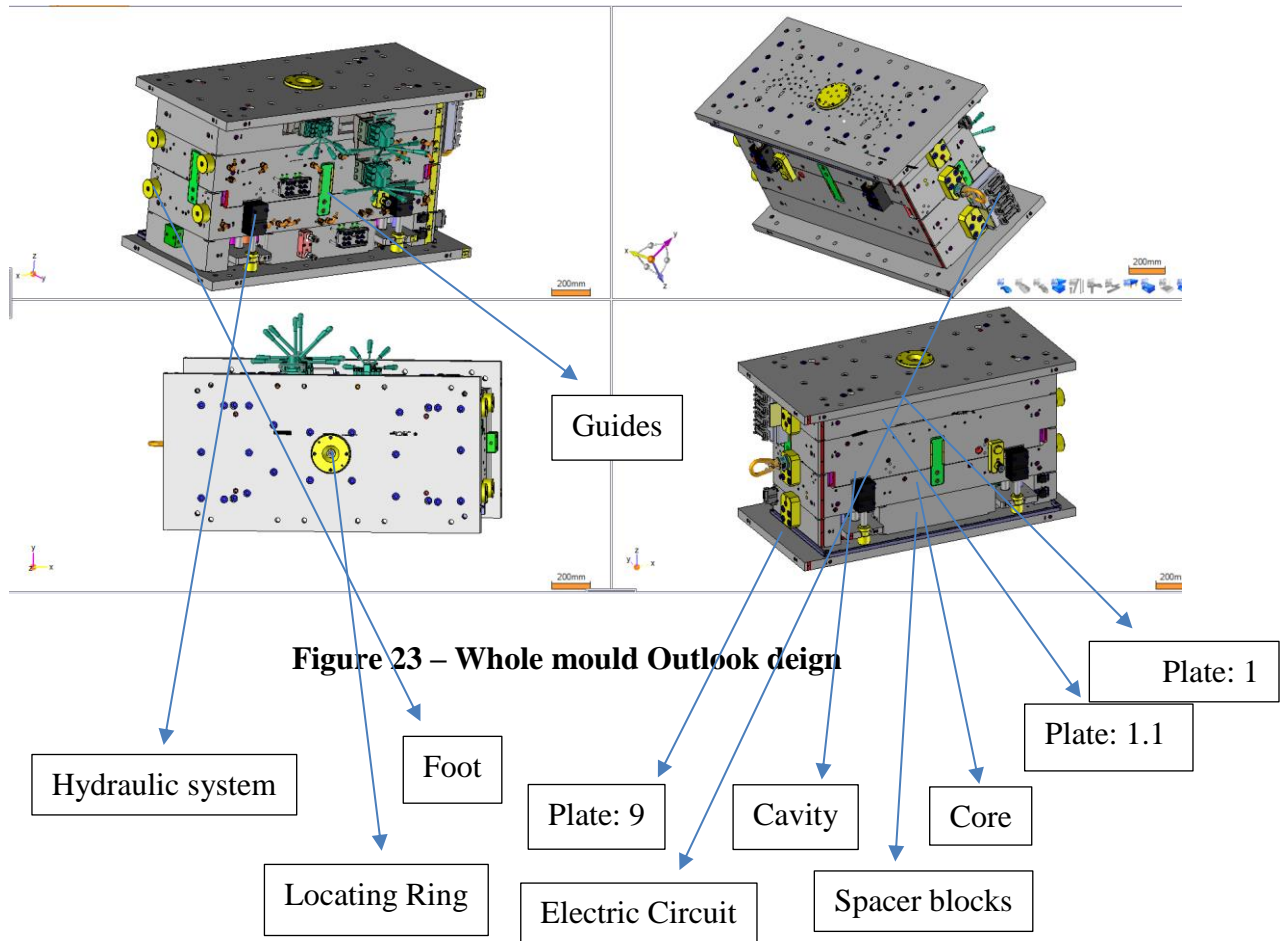

For example: if the material shrinkage is calculated to be one-hundredth of an inch to six inches long, a total of 6-hundreds of an inch must be added to the design to compensate for the shrinkage. In addition of draft angles or tapers are machined into the side walls of the cavity set to facilitate part removal from the mold. These tapers typically range from 1 degree to 2 degrees per side. Once done, low set heat can be used to protect them from an infusion environment. The molds may also be coated or plated with nickel and hard chrome wear resistant surface material. The middle part of the molds is called as a parting line. Depending on the complexity of the part, there may be many divisions of the parting line. Proper alignment of the mold halves is accomplished by using leader pins and bushings. To avoid mistakes one of the sets leader pin/bushing is dislocated from the metrical position. Now-a-days a more common way is to use a different internal diameter for the bushing and

componently for the leader pin. Due to outside diameter are equal in all the four sets, this allows the plates to be symmetrical regarding this point of view. The mold halves are mounted on parts which are components of the injection machine, most of the injection machines have three parts [16].

- The stationary part, which holds the A half of the mold;
- The movable part, which holds the B half of the mold and moves back and front on the injection machines;
- The rear stationary part, which holds the other end of the bars, thus the entire system;

A locating ring in the mold centers to a hole on the fixed area. This then allows the nozzle of the heating cylinder to seat firmly against the sprue bushing on the A half of the mold.

The sprue bushing directs the molten material from the heating cylinder nozzle into the molds runner system.

A mold runner system is a channels or channel network through the material flows to reach the cavity set [30]. Surface runner is the most common runner design, and half circuit channels machined into the surface of mold halves. When the melt thermoplastic flow through the molten system, it reaches the cavity set formed by the interface so called as gate.

The mold gate restricts, and controls flow of plastic in the mold. The path through the gate causes a frictional rise in the temperature of the material, expanding the flow of materials to the molten zone. Common types of gates present in the mold:

- In the Edge gate, it is usually located on the parting line and it is a general gateway;
- In the Submarine gate, it brings the material under the parting line to fill the cavity;
- In the Tabe gate, it redirects the flow of the material;
- In the Ring gate, it is used in the molding round or cylindrical part;
- In the Fan gate, it is used to spread material quickly over a large area.

To remove the air and process gases through injection, a mold venting system is required. The number and size of the vents are determined by Part Geometry, Material Type, Viscosity and the Rate of Injection. These vents are ground on the parting line of the mold. Hot thermoplastic will be under pressure until it gets cool. This cooling system is usually achieved through the cycling of water on the circuit of the mold. Proper cooling contributes to control Part Shrinkage, Part Strength and quality. In totally, the speed of injection of

plastic in the molds is controlled by the efficiency of the cooling system. When parts are sufficiently cool and solid, the movable open and discharge mode generally helps in the form of knockout pins, is used to aid in part ejection. Ejector systems are mounted on the ejection area of the mold, which are usually carried out by Pneumatic and Hydraulic cylinders. In addition to knockout pins, other emission modes include Stripper plates, Stripper Rings and Air Pressure Exhaust. Sometimes a sprue puller is used to remove the plastic from the sprue bushing as a part is ejected.

3.7. Injection Molding Machine

The Injection moulding machine to create a moulded product by plasticize the raw material inside the heating cylinder, injected into the mould and soldering it inside. The moulding machine is built with a mould clamping device that opens and closes the moulding device, and the machine that plasticize the material and inject the moulding material. There are many types of injection machine and their difference is made by how these two devices are organized [22].

- **Horizontal Injection Machine:** In this type of injection machine both mould clamping devices and injection machine components are fixed horizontally.
- **Vertical Injection Machine:** In this type of injection machine both mould clamping devices and injection components are fixed vertically.

3.7.1. Design of Injection Molding machine

The Injection machine will be of different types, depending on the type of volume we want, the clamping pressure, the nozzle system and the injection mechanism. In this type of Injection machine mainly it has two units.

- Injection Unit
- Clamping Unit

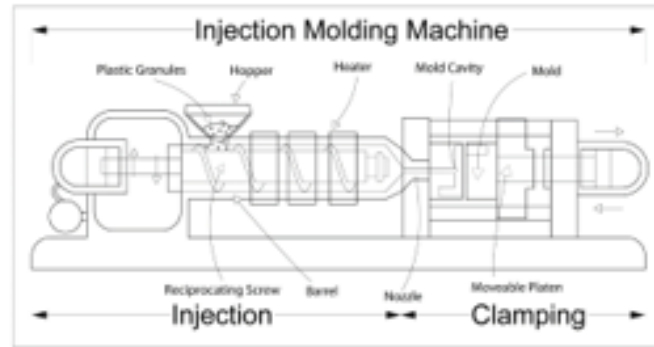

Figure 24 – Injection Moulding Machine [8]

Injection Unit: In Injection unit serves two functions: the material needs to be continuously and accurately fed, prepared, and sized at high pressure the volume of the material must be injected into the mould. It has a several distinct section like hopper and feeder throat section, Screw section and the Injection Nozzle section. There are several injection moulding parameters associated with the operation of the injection unit. These include settling the Melting temperature, settling the correct shot size, Setting the needle speed, and the mixing speed of the screws controlled by the Screw back speed. This is called as back pressure. This injection unit can be placed directly on the spruce during injection or to be retracted when dosing and cleaning if necessary [17].

Injection Capacity: The Proper injection potential is seen from the relationship of the Moulding mechanism to the weight of the 1 shot in injection. It is necessary to select a moulding machine that meets the potential of the mould. On the side where the capacity is small, the plasticization time and the injection time are prolonged, and it is used in short space capacity of moulding machine. This is a filling shortage due to the extension of cycle and also slow in filling rate.

Barrel: Generally, it's better to use the material such as Nitride steel to design Iupilon/Novarex. However, with respect to the design of the glass fibre reinforced quality (such as Iupilon GS) and the optical quality (such as Iupilon H-400). It is advisable to consider the barrel material. For a glass fibre reinforced system, it is better to use Bimetal (Dual-structure cylinder enclose with another metal and centrifugal casting) to prevent barrel abrasion. For example, (H-alloy Hitachi metals ltd, N -alloy Japan steel works ltd and K-alloys Kobe steel ltd).

Screw: In Screw design has a basic design based on the smooth conveyance of pellet, Plasticization for melting, compression and measurement with a little randomness.

- **Supply (Feed Section):** Stock particles have been long formulated to expose and melting the pellet, and also to increasing plasticity quantity.
- **Compression (Compression Section):** Turn out the air and water involved in the feeder section to the hopper side. In addition of adequate melting mechanism is required. Since plastic is a high viscosity material and it is fast compression type, its unsuitable compression type with gradually increasing external diameter.
- **Measurement (Metering Section):** Measurement in order to suppress the randomness of measurement, and usually stocks are designed to be long (4D-5D or more)

Backflow and Check Ring: This valve is used to maintain the injection pressure by preventing a part of measured resin from the backflow valve through the dich of the screw at the time injection.

Nozzle: Nozzles is used to transfer the resin from the injection chamfer to the mould or simply its help to inject the plastic to the moulds. And it is fixed on the machine side of the injection moulding machine. There are two types of nozzles are available,

- **Open Nozzle**
- **Shutoff Nozzle**

Normally they use only open nozzle, because it easy to be drooling and stringiness. Mainly it's necessary to avoid the shutoff nozzle due to the resin stagnation.

Heater: In these kinds of plastic material are melted in the high temperature, and in the heater the heat capacity is around 370° C usually in injection machine Band heaters are used.

3.7.2. Clamping Unit

In Clamping unit serves a several functions: It holds the core and the moulding cavity with proper alignments with each other with guiding pins. Covering the entire moulds during the injection process by applying the amount of clamping force required to counteract the injection force. To open and close the mould at prior time during the cycle. In clamping units have two plates, a fixed plate and a movable plate. These plates have a lock to hold the core and cavity. Mechanism for the movable plates is basically a power pressure and its operated

by hydraulic piston or mechanical toggle device. Hydraulic clamps are used in the large tons of moulds like 100 to 150 tons of moulds. These kinds of clamps are more flexible than the Toggle clamps in terms of setting tonnage at the given position during the stock [20].

Main motive of this chapter to discuss about the Injection moulding process, brief overview of the plastic industries and discuss about the industrial revolution in glass moulds. If we discuss about the Injection moulding means, it's necessary to discuss about the types of moulds and components of the mould. In injection moulding one of the the main processes is the cooling system. In further chapter it is addressed the cooling system and cooling circuits.

4. Mould Cooling System

The mould cooling process accounts for more than Two-Thirds of the total cycle time in injection moulding thermoplastic parts production. An efficient cooling circuit design decreases the cooling time, it's very helpful to increases the overall productivity of the moulding process. Moreover, stationary cooling system increases the plastic parts quality by reducing residual stresses and maintaining dimensional accuracy and stability.

A mould cooling system usually consists of the following items;

- Temperature controlling unit;
- Pump;
- Hoses and Supply;
- Cooling channels in mold.

A cooling system is necessary for the moulds. It has an external pump connected to passageways in the mould. During the injection process water is passed through the mould to remove heat from the hot plastic. The air must be expelled from the mould cavity as the plastic is injected inside. Most of the air passes through the small ejector pin clearances in the moulds. In addition, there are short air vents, often machined into the parting surface; These channels allow air to escape, but they are too small for the viscous polymer melt to flow through. Usually, the air vents are made in the area closest to the moulding zone or sometimes near the adjustment zone. This makes it easier to let air out [28].

4.1. Conventional Straight-Drilled cooling channel

The most common types of Conventional straight-drilled cooling channel consist; there are 3 types of cooling channels are used normally in the moulding field. It will explain detail below,

- Parallel cooling channel;
- Serial cooling channel;
- Conformal cooling channel.

4.1.1. Parallel cooling channels

In this type of cooling channels are drilled straight channel, which the flows of coolant from a distribution manifold to a collection of manifolds. Due to the flow characteristics of Parallel cooling channel, the different cooling flow rates may be different depending upon the flow resistance of each and every cooling channel. This is a variation of the flow rate; the heat transfer efficiency of the cooling channel varies from one to the other. As a result, mould cooling is not the same with a parallel cooling channel configuration [28].

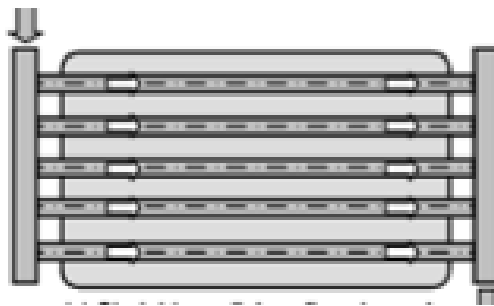

Figure 25 – Parallel cooling channel [8]

4.1.2. Serial cooling channels

This cooling channel are connected in a single cycle from the cooling gate to its outlet are called serial cooling channel. In this type of cooling channel network is commonly used in practice. By design, if the cooling channels are the same in size, the coolant can maintain its turbulent flow rate over its entire length. The turbulent flow helps to convert the heat very efficiently. In the large moulds, more than one continuous cooling channel may be required to assure to maintain stable cooling temperature and thus uniform mould cooling [28].



Figure 26 – Serial cooling channel [8]

4.1.3. Conformal cooling channels

To get a uniform cooling, the cooling channels must match the surface of the mould is known as the Conformal cooling channels. The implementation of new types of cooling channel for plastic parts with curved surfaces or free-form surfaces is based upon the development of Solid free-form technologies (SFF). These type of cooling channels can be created through a U-shaped milling groove using a CNC milling machine. Conformal cooling channels are different from the Straight-drilled conventional cooling channel. In conventional cooling channel, the free-form surface of mould cavity surrounded by straight cooling lines machined by drilling method. It's very clear that the cooling lines and the mould cavities vary with the distance from the surface and the uneven cooling occurs in the designed area. Conversely, for the conformal cooling channel, there is an almost constant distance between the cooling paths and the mould surface. It has been reported that these types of cooling channels offer a temperature distribution in the molten zone rather than the usual one [33].

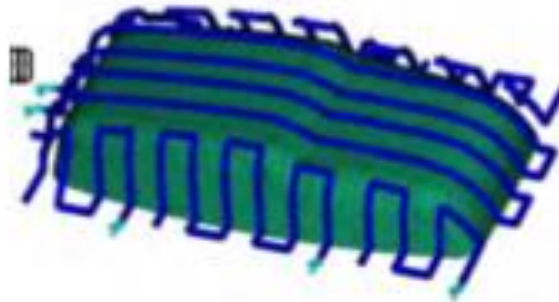

Figure 27 – Conformal cooling channel

4.2. Remarks for cooling system

In injection moulding, cooling system acts as the major role. The cooling time is the longest circuit of the injection moulding process, which takes 50 to 80% of the moulding circuit. Molten raw plastic material has a high temperature, while the plastic is injected and if there are no cooling channels are placed inside the mould means. It causes mould defects, while the plastic gets injected, some of the defects are mentioned (bending, sinking marks, and weld line). And also, some remarks are discussing below,

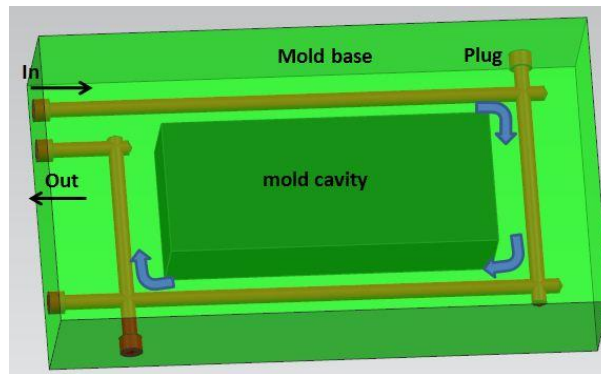

Figure 28 – Cooling channel circuit inside view in Cavity

- **First condition** is, when we design a mould, we need to create a cooling channels near to the largest thickness of the product.
- **Second condition** is, the diameter of the cooling channel is usually larger than 8 mm, which is equally required by the cooling channel.
- **Third condition** is, adjusts the mould temperature by pouring large quantities of water close to the temperature required for moulding.
- **Fourth condition** is, to avoid the enlargement of the diameter of cooling channel prefer to increase the number of the cooling channels.
- **Fifth condition** is, use a high heat conductivity mould material to improve the efficiency of the cold water.
- **Sixth condition** is, first it is necessary to conform the insert core and slider core to be cooled, if it is not cold meaning it is necessary to change the mould design or mould format.
- **Seventh condition** is, Best approach in cooling channels is to increase the number of cooling channel rather than increase the length of the cooling channels.

In this chapter is belong to the cooling channels and different types of cooling channels. For the cooling channels, Deep hole drilling process acts as a main role. So, the further chapter is belonging to the Deep drilling process and different kinds of drilling tools are used in the mould are explained.

5. About Deep Hole drilling

A Deep hole drilling is defined by its Depth-to-Diameter ratio ($D: d$) and typically holes greater than 10:1 are considered deep holes. The deep hole drilling in the metal has various applications in many industries. In this type of drilling consists of BTA drilling and GUN drilling. Additional processes designed for specific tolerance purposes and are usually performed in BTA-style deep hole drilling machines. Deep hole drilling from is used in various material like a super alloy, and is capable of touching tight diameter control, straightening and superior surface finish in the work pieces. Deep hole drilling processes using the special tools and system with the high-pressure sheets to clean the chips and obtain the Depth-to-Diameter holes in the metals to a general CNC machine. It allows the manufactures to achieve their productivity tolerance and productivity based on reliability, accuracy and its performance. Deep hole drilling is done in the Separate CNC machine and it's designed to improve the performance and efficiency processes. These technology developments allow CNC machining centres, tools with high pressure through the spindle coolant, a finite depth should have the ability to accumulate the Depth-to-Diameter. In Deep hole drilling method, there are two different kinds of tools are there [38],

- Gun drill
- BTA drill

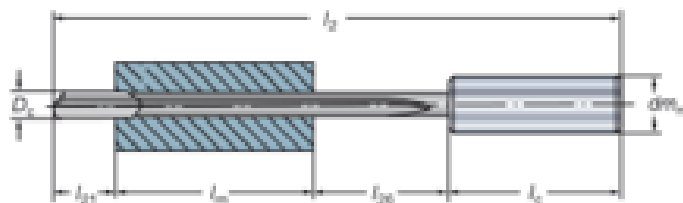

Figure 29 – Gun drill tool specification [38]

- D_c = Drill diameter
- L_2 = Overall length with or without driver
- L_{21} = Addition for regrinding
- L_m = Depth of hole

- L_{26} = Minimum chip evacuation distance
- L_c = Length of drive
- D_m = Driver diameter

5.1. Specification for Gun drilling

It is an ideal process for a deep hole drilled depths and diameters. Using this specific equipment to maintain accuracy and precise accuracy of gun speeds in very deep holes and small diameter holes. The process as inside cooling and chip removal due to the long and narrow holes that are being machined (Figure 30)

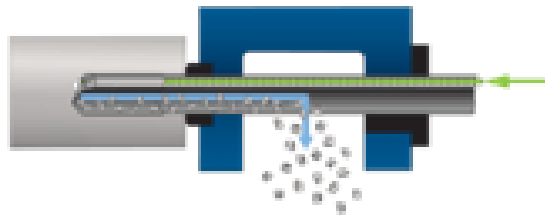

Figure 30 – Chip removal methodology in gun drilling [38]

Table 5 shows ranges of values for the diameter of the holes and his implications on the selection of the method and tool.

Diameters range	Description
1 – 3 mm	With proper equipment
3 – 25 mm	Common
25 – 50 mm	Common
50 – 70 mm	Possible than BTA appearance, but less productivity

Table 5 – Gun drill tool specification

In Table 6 is made a presentation of different ratios between diameter and length of the hole and the method that should be used to perform those operation of drilling.

Diameter ratio	Description
5:1	Common twist drill
10:1	High performance twist drill with cooling equipment
20:1	Deep hole drilling equipment for cooler specialized equipment
100:1	Gun drilling on a dedicated machine
200:1	Gun drilling tool on high performance gun drilling machine
400:1	Extreme drilling range and requires proprietary process and equipment

Table 6 - Gun drill D:d ratios (Diameter: depth)

The relation between the spoken ration can be analysed, in a graphic way, in Figure 31. It can be seen the challenge that represents drilling a hole of ratio 100:1 taking in consideration that it is performed, often, in hard materials.

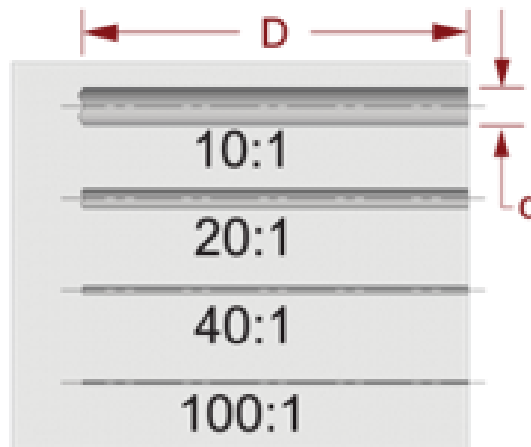

Figure 31 – Gun drill D:d ratios

5.2. BTA drilling

In BTA-drilling tool has three cutting inserts and two guiding straps. In this type of drilling tool heads are twisted or mounted in long drilling tube and use multiple cutting surfaces in one tool to effectively remove chips, exhaust them using the high-pressure coolant through the tool head, then the drill tube and the machining spindle. TiAlN coated carbide insert and straps are bonded to the tool body. And these processes involve the use of

a special drilling tool with a long inner tube, which allows the separation of cutting fluid and metal chips with more efficiency while it compares to the Gun drill tool. This tool can reach a minimum diameter of 12 mm until 300 mm in diameter. BTA drilling tool tips have various kinds of tungsten carbide inserts that allow for multiple cutting surfaces and work on materials with high hardness.

If we create a comparison between the two processes (BTA drilling tool and Gun drill), BTA tool has some advantages over gun drilling because of the higher drilling rates due to the design of the cutting tool, highly efficient extraction of metal chips which allows for greater efficiency compared to gun drilling [39].

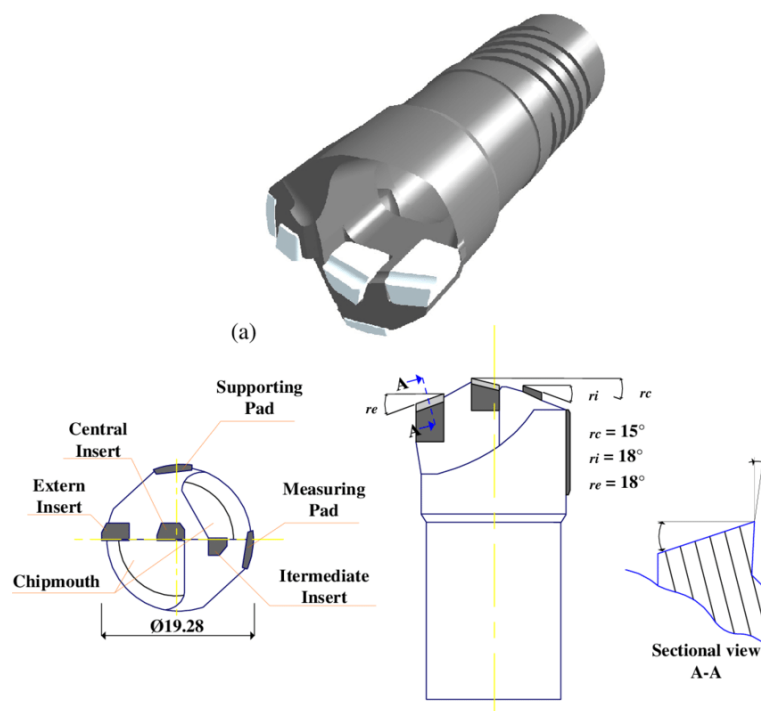

Figure 32 - BTA gun drill tool with plackets [39]

5.2.1. Specification for BTA gundrill

BTA deep hole drilling is the best process for longer deep hole drilled depths and diameters. In this kind of drilling tool have a different tooling diameter range,

- 8 – 65 mm = Brazed Disposable BTA
- 10 – 114 mm = Spade drill BTA
- 16 – 28 mm = Indexable BTA with a Single insert
- 25 – 300 mm = Indexable BTA with a multiple insert

5.2.2. Different types of BTA drilling tool

In BTA drilling equipment are typically penetrates 3-5 times faster than the penetration rates of Gun drill.

- **Brazed Disposable BTA drill:** In this type of BTA drill is an indexable tools, and it consumes replaceable carbide inserts. Brazed Disposable BTA drilling tool are effective in deep hole drilling process with disposable and relatively to small diameter. Drilling diameter range (8 – 65 mm). Cooling flow is from the external from the tool.
- **Indexable BTA drill:** Indexable BTA drilling tool use carbide inserts that consumed during the metal cutting process, and the inserts can be replaceable with a same tool body. In this type of drill have two types of tools (Indexable tool with Single inserts and Indexable tool with Multiple inserts) the only difference between these two tools are tool diameter range.

5.2.3. Deep hole Drilling process

Deep hole drilling process is mainly for the machining of holes, it can drill 10 times deeper than the drilling hole diameter. In this process have a different kinds strategy like BTA drilling and Gun drilling. Main challenges are we facing in deep hole drilling process is efficient cooling control and chip removal methodology.

Gun Drilling tool	BTA Drilling tool
Gun drilling process is for small diameter holes up to 50 mm. The process of origination of a gun drilling may differ from the appearance of BTA due to the cooling entrance and chip removal; the gun drilling tool is introducing to cool indoors by a small hole inside and the chips are removed by cooler through a dent outside of tool length	BTA drilling machines are introduced extremely cooling, through an assembly around the instruments and at the same time exhaust through drilling field.

Table 7 - Differentiation table between the Gun drilling and BTA drilling tool

5.2.4. Rotating Tool

Usually non-balanced elements or off-centre holes are used for round parts. The cutting tool speed is determined by rotational speed. Driller may be remarkable when compared to stainless work or counter rotating processes.

5.2.5. Rotating Workpiece

Usually round parts are used by a deep on centre hole. Reduce the speed is balanced by the area to allow higher rotational speed. The drum flow is reduced when compared to the rotational device.

5.3. Highly Productive Gun drill tool

In Solid carbide gun drill have a two types of gun drill. Only difference between the Single lip gun drill and Double Lip gun drill is the Solid Carbide. In the Single Lip it has only one carbide with one Partition side, but in the Double lip it has a double Partition in the carbide.

- Single Lip Gun drill
- Double Lip Gun drill

Table 8 presents specifications of gun drill tools design to perform at high productivity conditions.

Description	Values
Diameter range	(0.8 -12.00 mm) (0.031 – 0.472 inch)
Hole depth	300 mm (11.811 inch)
Hole Tolerance	IT8
Surface finish	0.1-0.3 μm
Filter resolution	5 – 10 μm
Coolant lubricant	Coolant required
Viscosity	\emptyset 0.8 - 2.0 mm = (7 – 10 mm^2 / s) \emptyset 2.0 – 12 mm = (10 – 20 mm^2 / s)

Table 8 - Highly Productive gun drill specification

5.3.1. Single lip Gun drill

In Single Lip gun drill has the ability to make a straight gun drill with the better results (specifications are shown in Table 9). This tool (Figure 33) is designed for perform a deep hole drilling in any material, it is a custom fit for every application and is available in a variety of carbide standards and coatings to help to remove tool life and chip ejection. In single lip gun drill have two different kind of tools [31],

- Single lip gun drill with brazed
- Single lip gun drill with solid carbide

Single lip gun drill is available in different design, in this type of gun drill have a main difference is brazed-on drilled head. [1]



Figure 33 – Single Lip gun drill tool

Description	Values
Diameter range	(1.90 – 40.50 mm) (0.075 – 1.594 inch)
Hole depth	$\leq 100 \times \text{diameter}$
Hole tolerance	IT9
Surface finish	0.1-0.3 μm
Filter resolution	10 – 20 μm
Viscosity	\varnothing 1.9 – 40.50 mm = (10 – 20 mm^2/s)
Cooling lubricant	Coolant required

Table 9 - Single Lip gundrill specification

5.3.2. Double Lip Gundrill

Double lip gun drill feeding rates can be doubled compared to a single-lip gun drill. This type of gun drill (Figure 34) based on the combination of the geometric angles and clearances, it is able to reduce the chip load up to 50% and it can reach greater penetration [32]. The specific benefits of our double lip gun drill are the high feeding rates that achieved in short chipping materials compared to the single-lip gun drill. [35]



Figure 34 – Double Lip Gun drill tool

Specifications for this kind of tool are shown in Table 10 and the angles of the lips commercially available are presented in Table 11.

Description	Value
Diameter range	(6.00 -26.50 mm) (0.236 – 1.043 inch)
Hole depth	$\leq 100 \times \text{diameter}$
Hole tolerance	IT10
Surface Finish	1.0 – 4.0 μm
Filter resolution	10 – 20 μm
Viscosity	\varnothing 6.00 - 26.50 mm = (10 – 20 mm^2/s)
Cooling	Coolant required
lubricant	Suitable for short chipping method. Feed rate can be increased compared to the single lip gun drill.

Table 10 - Double Lip Gun drill tool

Origin	Angle B	Angle A
1	35	7
2	35.5	10
3	15	15
4	30	0
5	0	20

Table 11 - Different angles in gun drill tool

5.3.3. External chip removal method in Gun drill

Many kinds of tools have been developed for accurate hole drilling and reaming holes are used under the pressure coolants. The most widely used external chip removal gun drill tool is made by three parts. Usually these three parts are solidly together [4].

- Tip
- Shank
- Driver

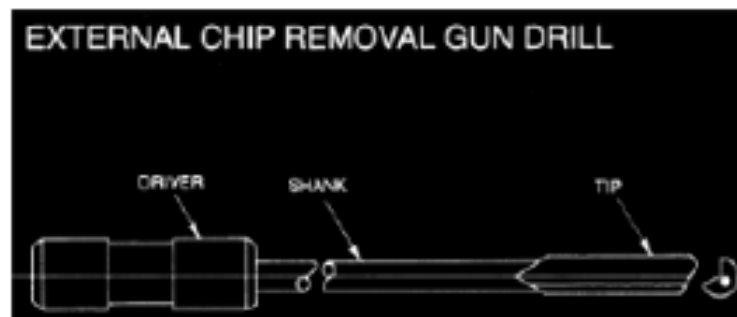

Figure 35 – External chip removal Gun drill tool

Tip: In gun drill maintain a three critical part, the tip of the tool cuts the hole and also it maintains the accuracy of the pilots directly through the hole assembly for making a straight hole, producing a true and high coating walls. Best carbide grade tip is used very long-life service and also guaranteed for the tool. A properly designed carbide tip can make an accurate hole and it can pass through almost any object. The gun drill tool reduces the duration of machine working time while compared to the normal drilling tool. These carbide tip can be re-sharpened almost repeatedly back to the shank. The diameter of the tip is slightly larger than the nozzle of the shank, thus helping to freeze the shank without touching the hole wall. In the centre of the tip have a two terminal of holes is the oil channel the oil channel makes a generous flow of high pressure of coolant to cut area.

Shank: One edge of the shank is connected to the driver, the other to the tip. The length varies with the holes deeply drilled and space for the machine elements. The shank should be properly adjusted and maintained the cutting edge is strong and it has a strong enough to absorb the cutting torque thrust as well as centrifugal forces. Stiffness of the shank with transfer minor misalignment in the machine to the tip. On the other hand, it should not be flexible enough out of the machine. A Shank of the gun drill is prepared from flexible heat treatment steel pipe, slightly smaller the diameter compared to the tip of the tool, which comes from suitably created a long Vee groove cut out the edge. This Vee groove (V-flute) it allows to pass the chips through the gap and offers for chips cool from the hole. In the front end of the shank have a hole to guide a flute to the gun drill tip [4].

Driver: The driver of a gun drill provides a means of adapting the drill to the machine spindle. The most common style of shank is the straight diameter with a centre section undercut or notched to provide a seat for the locking set screws in the spindle nose.

5.4. Different types of Drills

5.4.1. Step Drill

To make holes with two or more different diameters. Step drill are mainly designed to perform two jobs on the single passage. It's mainly used to drill a hole with Counterbore and Chamfer. It can be re-sharpening or easily replace them with a special length. Step drill are available in taper length also.

5.4.2. Core Drill

A core drill is a cylindrical drill with an empty bit, which allows to create a fully circular hole in the hole you drill. Because the bit is hollow, the drilling material gets extracted from the centre. This type of drill can be used to drill through the wood, stone and also in ice with vertical and horizontal position.

5.4.3. Counterboring & Countersinking

In the process of counterboring produce a cylindrical cavity with the greater diameter at the head of pre-drilled hole. The pre-drilled hole is meant to hold the fastener and prevent the separation of the two working pieces when they are attached to their two flat surfaces. The larger cavity matches the width and depth of the fasteners head.

5.4.4. Centre Drill

It is also known as a slocombe drill bit, they are used in metal work to provide the opening hole for a large-scale drill bit or to create a cone indentation at the end of a work piece in which to mount a lathe centre.

5.4.5. Spot Drill

This type of drilling tool is mainly to ensure the accurate hole location by avoiding drill deflection. It is highly recommended, when a drill tends to leave the centre, especially in deep hole drilling. These drills are designed to make it for an accurately spot a hole for a twist drill.

5.4.6. Spade Drill

It is commonly called as a Paddle bits or Spade bits or Flat-bladed bits. Mainly some common peoples (such as Electrician and Plumber) are used to make a hole on the walls to create a wiring circuit or pipping circuit.

5.4.7. Crankshaft Drill

In this type of drill has a variation of a twist drill designed to drill deep holes particularly in hard material.

5.4.8. Gun Drill

It is mainly used to make a long hole up to 400 to 1800 mm. the coolant flow is in inside of the tool.

5.4.9. Trepanning

This type if tool is for, when piercing the skull and removing a part of bone, dura matter is exposed without any damages to the blood vessels and brain. Trepanning is used to treat health problems associated with intracranial diseases, reducing internal stress, migraines and mental disorders.

5.4.10. Twist Drill

Twist drill is widely used for all drill bit types, mainly it will cut almost everything like (wood, plastic, steel and concrete). This type of tool is mainly used in the metal cutting process. So, normally it made up of M2 high-speed steel.

Conclusion: This topic is belonging to discuss about the different types of drilling tool. In day today life there is a lot of drilling tools are available in market for different application. In molding industries, few drilling tools are used in these industries like (Gun drill, Step drill, Core drill and Centre drill). But for my case-study I use only gun drilling tool, because main motive is to create a long hole like a (water circuit). For long holes gun drilling tools are preferable by the companies.

This is one of the main chapters for the work. In this chapter, it contains about the deep hole drilling and its methodology, for example “How its work”, and different types of drilling tools are used in day to day life. Already, we discuss about the tools, so it’s necessary to discuss about my case-study. In further chapter will be discuss about the case-study and technical information about the machine I work in my internship.

6. Case-study on Deep Hole Drilling

In this Chapter mainly discuss about the Fixing system (Normal fixing and FPT fixing), machine setup and its parameters. Finally, we are going to discuss about the Case study of my work and its parameters of the work.

6.1. Fixing System

In CNC machine, one of the main case studies is depends upon the Fixing system of the workpiece. In Tecnimoplás they are using two types of fixing system,

- Normal Fixing system
- FPT (Fast milling) Fixing system

6.1.1. Normal Fixing System

In Normal fixing system, the workpiece is fixed with the help of T-slot table holder, T-slot nuts and different types of Clamp (Bar clamp, Step clamp and Toe clamp) and screws.

T-slot Table holder: T-slots holding method is the most common method and keep your ergonomic solutions. It is a most common way to positioning and holding down your work piece. It is very simple, strong and work very well to fix the work piece, if we want to connect any of the t-slot table use the other slippers that fit the T-slot nuts and the appropriate earring.

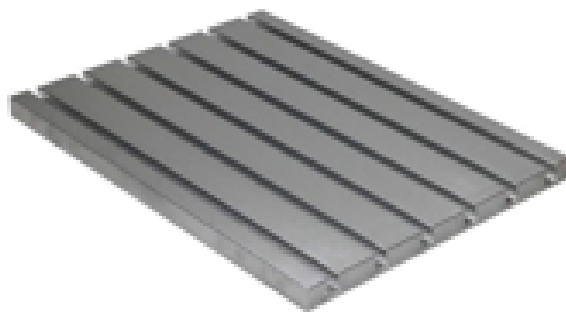

Figure 36 – T-slot table holder

Important aspects for the T-slot table:

Usually, this kind of fixing is used to fix the workpiece in Horizontal manner with the help T-slot nuts and Bar clamp. But some time it is necessary to fix the workpiece in Vertical manner, because of the height and they have some work in the front and back plane. If it is necessary to fix the workpiece in vertical position, they use another T-slot Table. It is in the vertical position. T-slots and about the clamps will be explained in further topics.

T-Slot Nuts: Although they are common, but there are some disadvantages of other solutions. Apart from the fact that T-slots can collect chips and other cracks, the biggest disadvantage is that your vice or other work holding fixture is difficult to regain onto the table. Every time a machine needs to be installed with a new workstation for a new job, it can work more. Overtime, the cost of performance will be very large.



Figure 37 – T-slot holder nuts

Clamps: In the Past day, they are using this normal fixing method. At that time, they are using some different kinds of clamping system to hold the work piece in T-slot holder table, it will be discuss below.

- **Bar clamp:** In bar type fixing usually we fix the work piece above the metal bars, but it needs some space (400 mm) from the starting point of working table, because we need a space to move the working table. And there is a standard size for the Bars:

Different sizes for the Bar clamps (Figure 38) that can be used are shown in Table 12.

Length	Breadth	Height
610	150	235
500	200	235
235	125	215
175	90	155
515	95	175

Table 12 – Different sizes for the Bar Clamp



Figure 38 – Bar Clamps

- **Step Clamp:** Step clamp (Figure 39 and 40) is one of the basic clamping systems, because they have little steps machined on them. It is commonly used with T-slots holder, although you can use them in a tool table with the help of T-slot nuts. Here are some common step clamps. You've got more clamping accessories to work so you can be handy over an extra set. By using the step blocks and using the long bolts, you can control the tallest things and clamp the big work piece. When using step clamp, keep the bolt close to the work piece rather than step block. Also, it can be helpful to angle the bottom clamp of the faded over the area by rising it one or two steps from the level. If you want, you can put the soft material in-between the work piece and clamp to avoid marring the work piece.

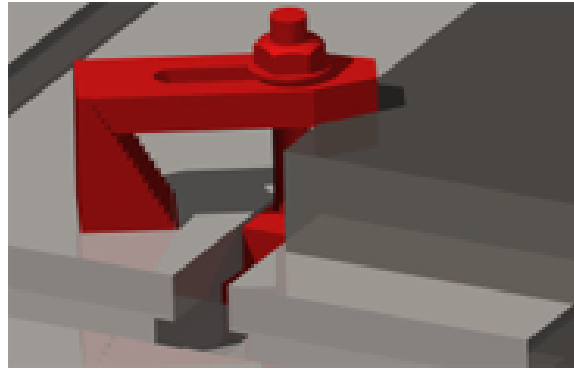

Figure 39 – Step Clamp



Figure 40 - Step clamp tools (screws, nuts and clamps)

- **Toe Clamp** (Figure 41): According to the Step clamp, it can increase the peak of the work, but sometimes it's difficult, because you may need to machine the area being gripped. Toe clamps grip the side of the work piece to give you full access to the top of the work piece. There are variety of different styles:



Figure 41 – Toe Clamp

6.1.2. FPT (Fast mill) Fixing system

The FPT fast mill product range includes a variety of formats designed to meet various requirements of the application. All products are divided into family and easy and quick advice should be made immediately.

Mechanical Modules: The hard and precise position of the hard and ground steel blocks is the self-centred three-jar tightening methods. They allow strikes to be restricted to a Vertical or Horizontal position and allow them to operate mechanically and easily on the sides without the use of vices and without the magnetic table. They are fully managed by CAD/CAM or simulator by the product library available in a standard format for any software. There is a similar set of different height that have the Position and Tightness of work environments with M6 to M60 threads [29].

- Line Inox,
- Single Modules,
- Double Module,
- Index Module.

Pins: Our standard stabilized pins package for mechanical modules a common range from M6 to M60 provides some innovative solutions (Patent pending) to maintain workloads in any object and dimension before and after Heat treatment.

Pneumatic modules FMZ: Accurate positioning and clamping – Pneumatic modules FMZ for fast and zero allows for rapid changes of pallets and large size of pieces. The range consists of fully equipped positioning devices without the functionality of the packaging devices and workplace refinements. All of which contain Pins with M12 and M16 thread sizes. With the cubes of different dimensions designed specifically for your needs and specific and matching solutions, the table can be adjusted purchasing the available FMZ tray range available in stocks, In addition to this parabolic, it has the unique single Pneumatic module of FMS, Which can be used for mechanical modules in FPT with which it shares the height and the type of centering. While this solution does not make it easy to deactivate mechanical blocks, strikes or plates will be adjusted when a quick change in static positions.

- Pneumatic Module FMZ
- Single Module FMZ
- KIT Plates with 4 module FMZ

- FMZ Cube

Plate modules: Stainless steel and tempered steel plates with calibrated seats and ground surfaces. They are designed to ensure accurate engraving positioning by measuring grid (usually with a grid pitch of 50 or 100 mm) blocks. They are available in standard editions in modular version for small/medium sized engines and large-scale engines, which ensure the precise stance of the measured scale. The possibilities are widely available in designing the pitch plates measured in stocks and tailor-made plates [29].

- Modular plates,
- Cube,
- Special plates,
- Circular standard plates,
- Standard plates.

Fixing Method for SINGLE MODULE:

Workpiece Preparations: Before fixing the workpiece there is a main condition to follow the workpiece preparation in FPT method. Usually in Single module have a standard size diameter (90 mm and Height 160 mm). Main motive of the single module is to reduce the time, while they fix the workpiece. For that FPT create an innovation idea. In single module needs some equipment to fix the workpiece in FPT. Fixing methodology is explained below,

Fixing Methodology: First it is necessary to check the holes in FPT table. After that use the pin (use of this pin is to connect the FPT module and FPT table) and fix the module with the help of M16 screws directly to the FPT table.



Figure 42 - Pins

After that second condition is to fix the Female pin into the workpiece. In female pine have one ring, one M16 screw and one pin. This female pin is used to direct the FPT module.

Next step is to fix the workpiece directly to the module and then tighten the module with the separated tool. Photographic view is shown below Figure 42.



Figure 43 – Female Pin

- Fix the bush into the Interface tray.
- Fix the Module with the help of screws.
- Fix the Pin and the Ring through the screw to the work piece.

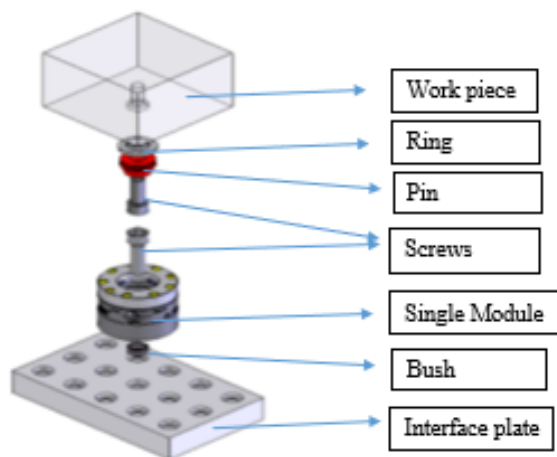

Figure 44 – Fixing Method for Single Module

Fixing Method for DOUBLE MODULE

Fixing methodology: The procedure is same to fix the workpiece into the table. But there is a little difference from the Single module, because in single module they use the normal pin to fix the module to the table. But in Double module, they use the Female pin to fix the module to the table. It's more accurate than the Single module. Because female pin has a good fixation process with table and workpiece.

- Fix the Pin and the Ring to the Interface plate with the help of screws.
- Fix the Module with the Pin.

- Fix the Pin and the Ring to the work piece with the help of screws.

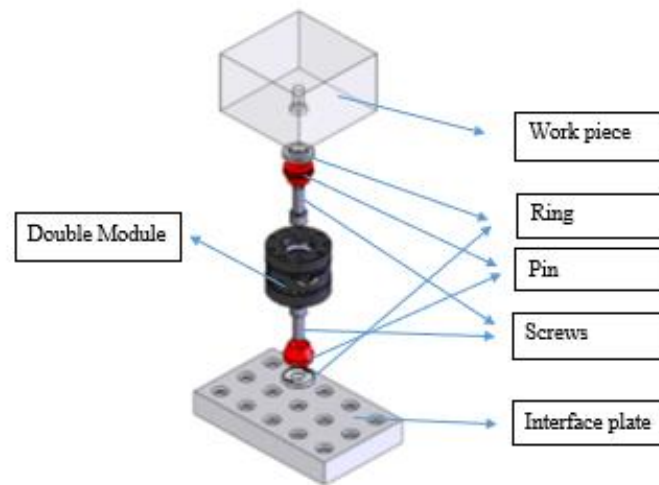

Figure 45 – Fixing method for Double Module

Advantages of FPT (Fast mill)

- Reducing the clamping time.
- Clamping force is high.
- Accuracy setting is zero.
- Work piece positioning accuracy is high.

6.2. Setup of Machines & Workpiece

Tool changing systems is quick and easily serve between deep hole drilling and grinding processes. Structured of this machine is used to increase the grinding capacity (Chip Removal Rate).

Main feature of this drilling machine is to create a long hole until 1600 mm., and it have tilting angle with $\pm 25^\circ$. This machine is one of the main machines from past days, because it has a lot of specifications and it can do every operation for example: Deep hole drilling, milling, threading and finishing the holes and finishing the outer work piece.

Main technical information is explained in below Table 13. But I can explain main features here. For the machine main feature is different types of axis they travel and Torque, Power and Speed. This machine belongs to 6-axis machine (X-2500 mm, Y-1200 mm, Z-650 mm, A- $\pm 25^\circ$, B- 360° , W- 1630 mm). And maximum Speed is 4500 rpm, maximum Torque is 429 Nm and Maximum power is 33 KW.



Figure 46 - Heto 2500 Master CNC machine

6.2.1. Technical Information about the Information

CNC axis	Mm	Inch
W-axis maximum	1630	64.2
X-axis maximum	2500	98.4
Y-axis maximum	1200	47.2
Z-axis maximum	650	25.6
B-axis maximum	360°	-
A-axis maximum	±25°	-
DRILLING CAPACITY	Mm	Inch
Drilling axis (W+Z)	1650 + 650	-
Drilling Capacity	∅ 5 – 40	∅ 0.2 – 1.58
MILLING CAPACITY	cm³/min	inch³/min
Milling	500	30.5
Rigid tapping	M34	-
Helical threading	Standard	-
SPINDLE UNIT	-	-
Spindle taper	ISO 50 DIN 69871	-
Speed	0 – 4500 rpm	
Power	22/33 Kw	30/45 hp

Torque	280/429 Nm	207/310 ft-lbs.
AUTOMATIC ROTATORY TABLE	Mm	Inch
Table size	1600 × 1300	63 × 51.2
Positioning type	360°	-
Maximum load in rotation	15 Tons	33.070 lbs.
LAYOUT DIMENSIONS	Mm	Inch
Total Weight	34 Tons	74.958 lbs.
Foot print (W×L)	6090 × 5500	239.8 × 216.5

Table 13 - Technical information about Heto 2500 master

Analysis: Compare to the other drilling machine, this machine has a high torque and speed, and another benefit is length of the tool travel inside the work piece W- 1600mm). Main motive of this machine is to create a long hole without any defects. Because for the cooling system deep hole drilling is the main process.

6.3. About the Tools

From this topic to know, what are the tools they using to create a mould in drilling section. We are using different kinds of tools in our machine it is shown below,

- Tester (3D tester)
- Drilling Tool
- Milling Tool
- Threading Tool
- Chamfer Tool

6.3.1. 3D- Tester

The 3d tester is the most accurate and versatile edge-finding equipment for all the CNC machines (laboratory diagnosis). Once the tester is fixed with a tool head and it is fully adjustable to zero. Then you can find the exact position of the spindle in the edges of the work.

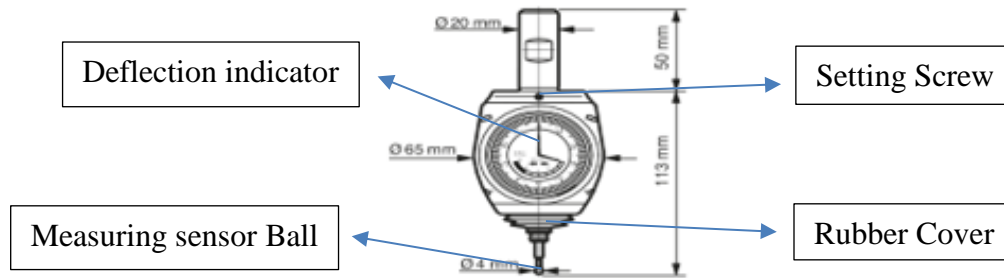

Figure 47 – 3D-Tester

Detail Analysis: To fix a proper 3D-tester means, it is necessary to know about the tools this belongs to this tool and follow some of the steps to fix the Tester. Rubber cover, Setting Screws, testing screws, Testing Gauge, Measuring sensor ball and Deflection of indication. Detailing of the parts in Figure 47,

First, fix the measuring sensor ball with the help of screw that placed upper side of the rubber cover. Fix the sensor ball in the middle of the rubber cover and tighten the screw that placed up of the rubber cover. It is necessary to verify the concentricity, if it is not fine it can be reset. Finally, it is compulsory to check centre alignment for the tester with help of comparator. Fix the tester into the tool head and then fix the comparator in the table. While the tester touches the comparator, it can show the difference. After that adjusting the settling screw to put in the centre.

Benefits

- Fast and accurate positioning.
- Find and set the null point of the work.
- With adjustable concentration.
- It works in 3-axes (X, Y and Z).
- It's suitable for all CNC and corrosion machines (bracelet between stylus and case).
- The real dimensions are independent of the reading direction.
- Accuracy is exceeding 0.01 mm.

6.3.2. Drilling Tool

In drilling tool, there are two different kinds of drilling tools are mainly used in the molding field. About these tools are explain below

- **Rapid Drilling Tool:** A rapid drill or hammering drill is a rotating drill with a hammering action and its abdominal efficiency provides a short, rapid hammer throttle with a relatively fragile material and effortlessly snoring.



Figure 48 – Rapid Drill

In Figure 49, It shows the deviation graph between the Length of rapid drill and Rapid drill diameter. There is a lot of deviation like up and down in this graph, it belongs to the length of the tool. Each and every tool has a different diameter and length. This graph is depending upon the tool that they use in Tecnimoplás and also the values are taken from the tool place in Tecnimoplás.

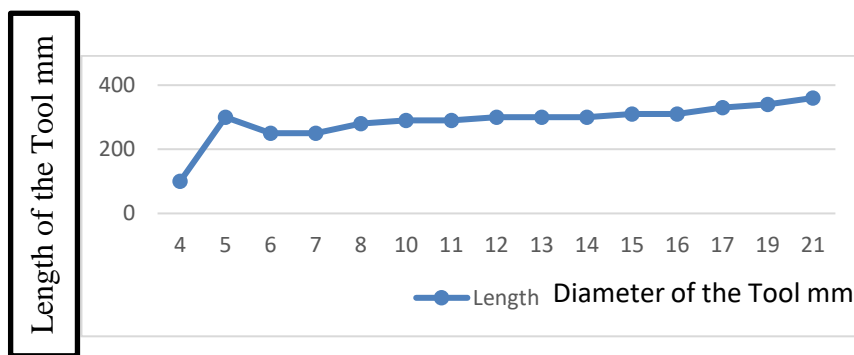

Figure 49 – Parameters for Rapid drill (Length vs Diameter of tool)

In Figure 50, it shows the graphical view between the Spindle speed and Tool Diameter. Normally, if the tool higher getting higher the spindle speed needs to be lower because to avoid the tool breakage. But some case (For example: $\varnothing 4$ mm for this tool is different from other, because this tool is very small. So, we cannot give too much of speed. Compare to other tools the speed needs to be very low to remove the steel in straight line.

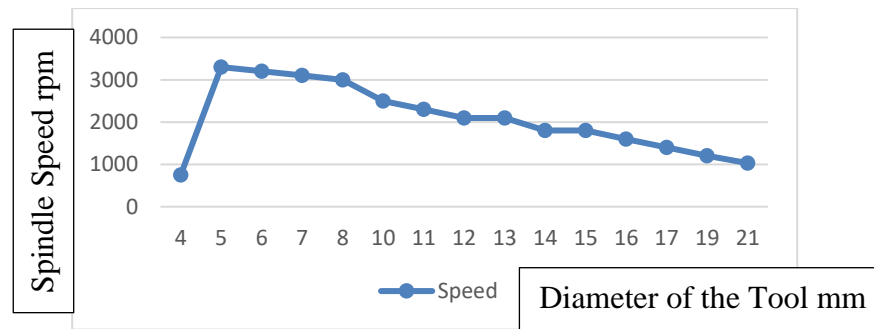

Figure 50 – Parameters for Rapid Drill (Spindle Speed vs Diameter of the tool)

In Figure 51: This graph is representing the different parameters between the Rapid drill diameter and Feed rate. This one is also same as a spindle speed. If the tool getting higher and then the feed rate needs to be low. This is a general rule in rapid drilling process. As explained above (For the $\varnothing 4$ mm it's totally different from the other tool).

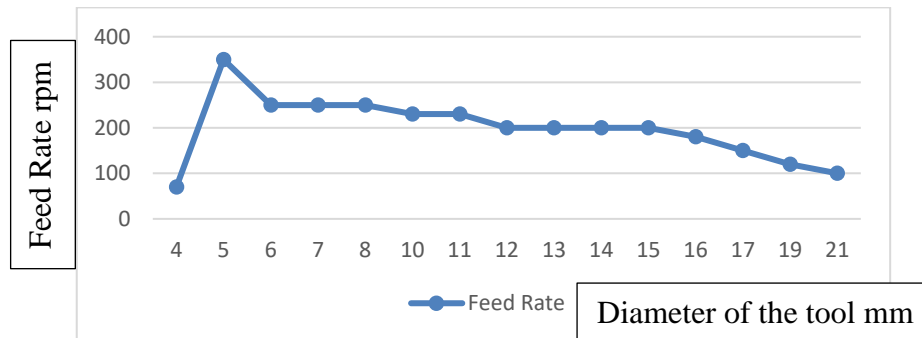

Figure 51 – Parameters for Rapid Drill (Feed rate vs Diameter of the tool)

- **HSS Drilling Tool (High Speed Steel tool):** High speed steel (HSS) is a form of tool steel; HSS are harder and more resistance than high-carbon steel. HSS drill can be used to handle metal like hardwood and other material, and it have a more cutting speeds than carbon steel and also it can often replace carbon steel. In HSS tool have a different diameter (2.5 to 40 mm).



Figure 52 – HSS drilling tool (HIGH SPEED STEEL)

In Figure 53: In this graph is belong to the Parameters of HSS tool and it represent the variations between the Tool diameter and Length of the tool. As mentioned earlier each and every tool have different types of length and diameter. This information belongs to Tecnimoplás.

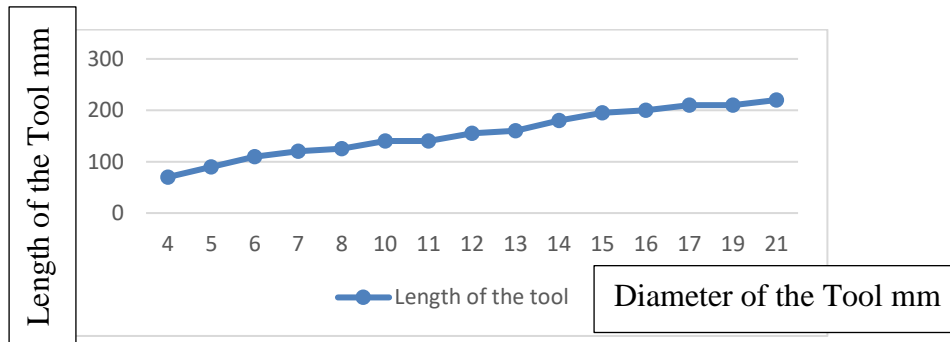

Figure 53 – Parameters for HSS tool (Length vs Diameter of the tool)

From Figure 54: In third graph represent the parameters between Tool diameter and Spindle speed for HSS (High Speed Steel) tool. Always the conditions are same, if the tool diameter gets higher the Spindle speed getting increase. HSS tool is totally different from the rapid drilling, because in rapid drill if diameter getting high speed and feed getting low. But in HSS, if diameter getting high the Spindle speed is also getting high.

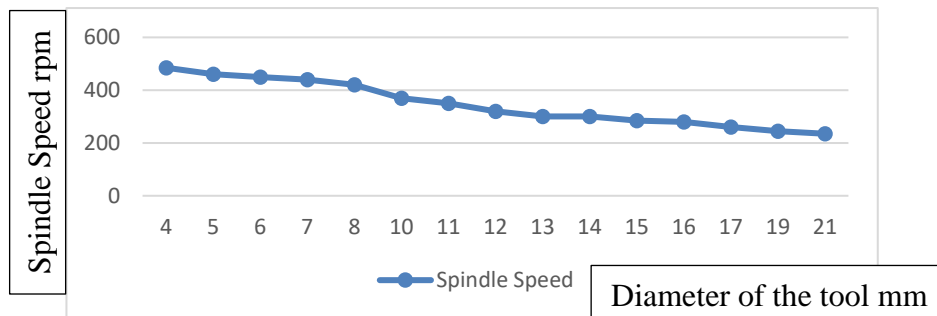

Figure 54 – Parameters for HSS drilling tool (Spindle speed vs Diameter)

In Figure 55: This graph is representing the parameters between the Tool diameter and Feed rate of HSS tool. For the HSS tool have more or less standard same feed rate with little increments between the tools. Conditions are same, if the tool diameter getting higher and then the feed rate is also getting higher. (In the graph shows the same feed rate from $\varnothing 7$ to $\varnothing 15$ mm), because as mentioned before sometimes feed rates are same. This value were taken from experiments performed during internship.

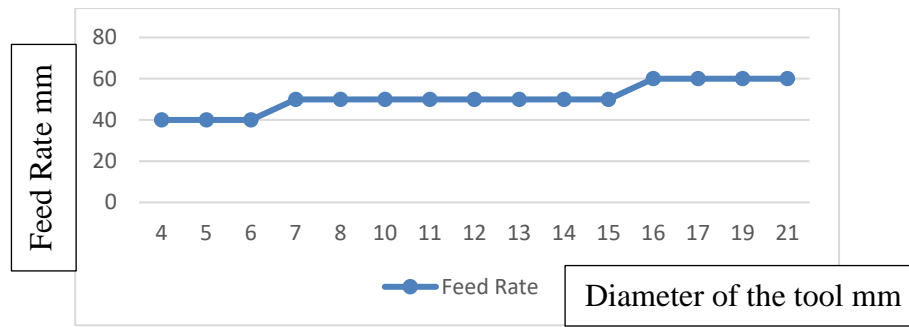

Figure 55 – Parameters for HSS drilling tool (Feed rate vs Diameter)

Differentiation table between the Rapid drill and HSS drilling tool

Rapid Tool	HSS Tool
In rapid tool, it's not necessary to make the pointing and pre-hole. Normally rapid drill likes to do direct drilling.	In HSS tool, it's necessary to create a pointer and pre-hole. This type of drilling tool can't make drilling.
Usually, Rapid drill are used in the CNC machines, because it's too fast compare to the HSS.	Usually, HSS drilling are used in both CNC machine and Conventional machine, but if it's used in CNC machine feed rate and Spindle speed needs to be slow to avoid the tool breakage.
In rapid drill coolant flow is from inside of the tool.	In HSS tool the coolant flow is always from the outside.

Table 14 – Comparison table between Rapid Drill and HSS drilling tool

Conclusive analysis for the Drilling tool (both Rapid and HSS):

If it's about the Rapid drill means, it looks lot of benefits from rapid drill like if they use the rapid drill means, it's easy to cut the steel with rapid movement, so its saves time. And also, it's not necessary to create a pre-hole. But the length of the rapid drill has a standard size. If it's necessary to create an inclination hole means, it's not preferable because of the length.

If it's about the HSS drilling means, for HSS drilling tool its necessary to create a pre-hole, because in HSS tool have a different length for a single tool (for example: if look about

the diameter 10 means it has a different length like from 140 mm to 600 mm) it just an example. But if they use HSS tool means it takes a lot of time to finish the entrance hole, because spindle rotation is low when they compare with the rapid drill.

I am going to conclude from this topic is, our preferable tool is rapid drill tool for the Straight hole. But if its inclined hole means HSS is a preferable to finish to avoid the collision between the Tool head and Working table.

6.3.3. Milling Tool

The Milling machine is the most common form, a material removal process, and can be created as a part of the unwanted material. Milling machines are very versatile. They are usually used on flat surface, but it can create irregular surfaces. The type of milling machine is typically found in the student stores is a vertical spiral engine with a vertical head.



Figure 56 – Milling Tool

- **Face milling** - Machining flat surfaces which on the right angle on the cutter axis.
- **Plain or Snab milling** - Machining on flat surfaces that are parallel to the cutter axis.
- **Angular milling** - Machining on flat surfaces that are inclination to the cutter axis.
- **Form Milling**- Machining surfaces having an irregular outline.

Different types of Milling Machines

- Knee-type Milling machine
- Universal Horizontal Milling machine
- Raw-type Milling machine
- Universal Raw-type milling machine

6.3.4. Threading Tool

Metric threading Tool with Normal Pitch: A threading tool is used to create a thread in a solid part. It is mainly used to remove external and internal threads in one or several passage and it is depending upon the technique chosen. Taps are commonly used to cut the internal thread up to 50 mm in diameter, taps are mainly for the hand taps, nut taps, machine-hand taps and threading-die taps [6].

In Figure 57 is to represent the variation between the standard values for the threading tool, because for the threading tool pitch is the important source. With the pitch value it possible to analyse several situations that will be explained in detail further ahead.

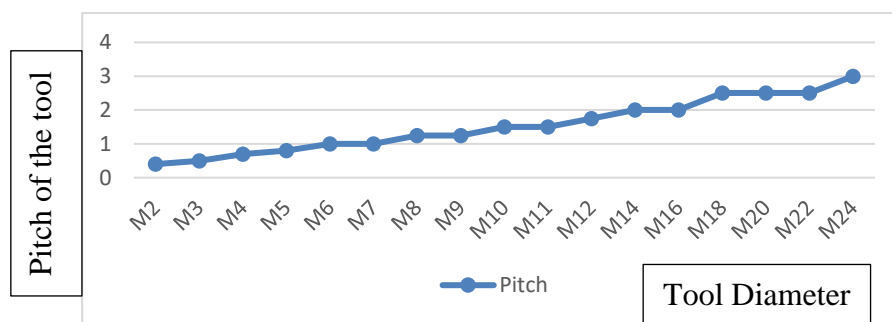

Figure 57 – Parameters for Threading tool vs Pitch of tool (Normal pitch)

In Figure 58 to show the Drilling tool values for the threading tools. While we do thread process, before drilling is the main process. If the pitch value is known, it is easy to find drilling tool diameter, as it is explained in detail below.

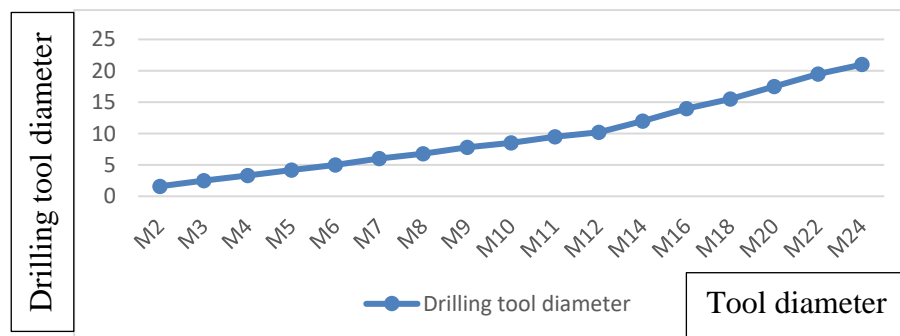

Figure 58 – Parameters for Threading tool vs Drilling Diameter (Normal pitch)

D_e = Exterior Diameter of the tool

D_p = Internal Diameter of the pitch

Drill = Thread - Pitch → Equation: 1

$$H = 0.866 P$$

$$h = 0.6495 P$$

$$t = 0.125 H$$

$$D_m = D_e - 0.6495 P \quad \text{Equation: 2}$$

$$D_p = D_e - 1.299 P \quad \text{Equation: 3}$$

$$r = 0.1082 P$$

For Example: $D_m = D_e - 0.6495 P$

$$D_m = 16 - 0.6495 \times 2$$

Drilling diameter tool $D_m = 14.7$

In this formula is used to find some the values that we can find, D_e – Exterior diameter of threading tool, P – Pitch of the tool with these values, it’s possible to find the Drilling diameter tool and find Threading tool diameter with pitch value.

Metric threading Tool with Fine pitch: It is common to assign metric texts with capital M and is an indication of their normal outer diameter and their pitch. For example (M 10 \times 1.5).

In Figure 59: As explained above in threading tool with normal pitch, Pitch value is the main for the threading tool for this type threading tool have a different types of pitch values. That’s the values are shown in the graph.

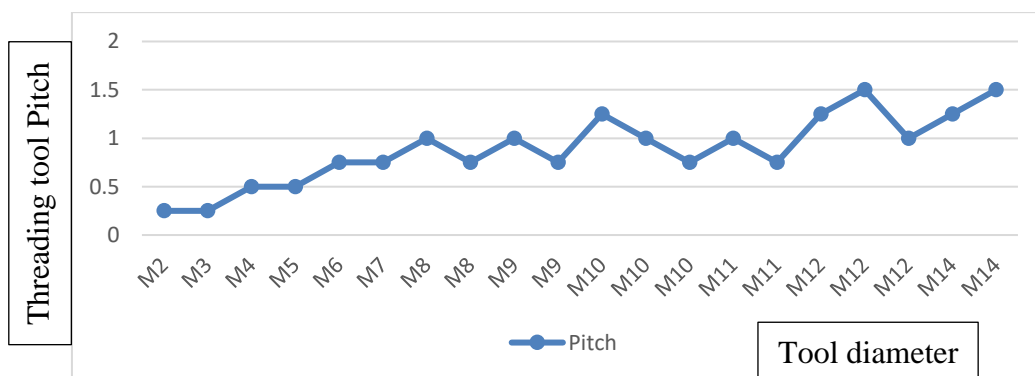

Figure 59 – Parameters for threading tool vs Pitch of the tool (Fine Pitch)

In Figure 60: It shows the different diameter for the drilling tool to use before the threading tool used. And it has a formula to find the drilling tool diameter. It will be explained below.

For Example: $D_m = D_e - 0.6495 P$

$$D_m = 14 - 0.6495 \times 1.5$$

Drilling Tool Diameter $D_m = 13$

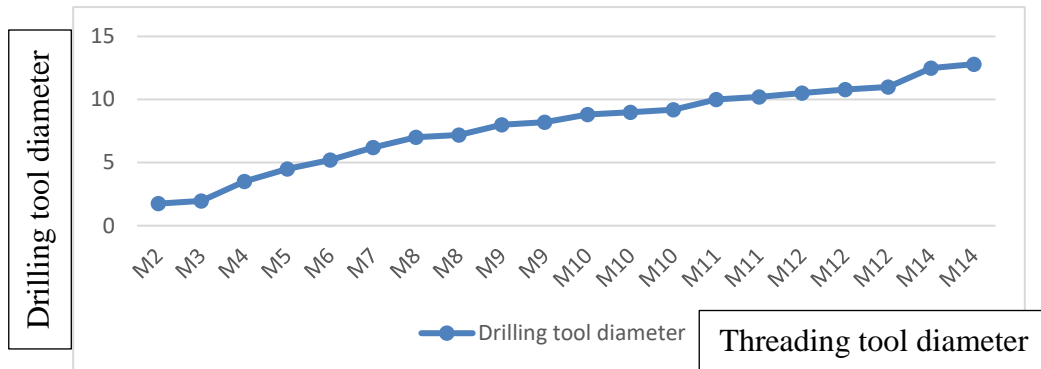

Figure 60 – Parameters for Threading tool vs Drilling diameter (Fine Pitch)

$$\text{Drill} = \text{Thread} - \text{Pitch}$$

$$H = 0.866 P$$

$$h = 0.6495 P$$

$$t = 0.125 H$$

$$D_m = D_e - 0.6495 P$$

$$D_p = D_e - 1.299 P$$

$$r = 0.1082 P$$

Comparison between the Metric Normal pitch threading vs Metric Fine pitch threading tool:

In Figure 61: This graph is representing the comparison chart between the Normal pitch and Fine pitch threading tool. With this chart we can find the comparison between the two different types of threading tool. These values are the standard values it taken from Tecnimoplás.

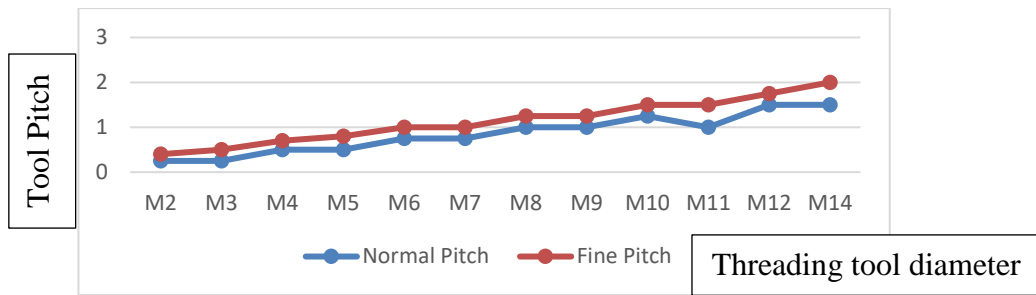

Figure 61 – Comparison between Normal pitch vs Fine Pitch threading tool

In Figure 62: This graph is used to know the difference value for Normal pitch and Fine pitch drilling tool. Already i explained about this topic, but this graph is used to know the comparison between the both the tools. According to this graph my opinion is almost the same but there is a little difference that is because of the pitch value for the tool.

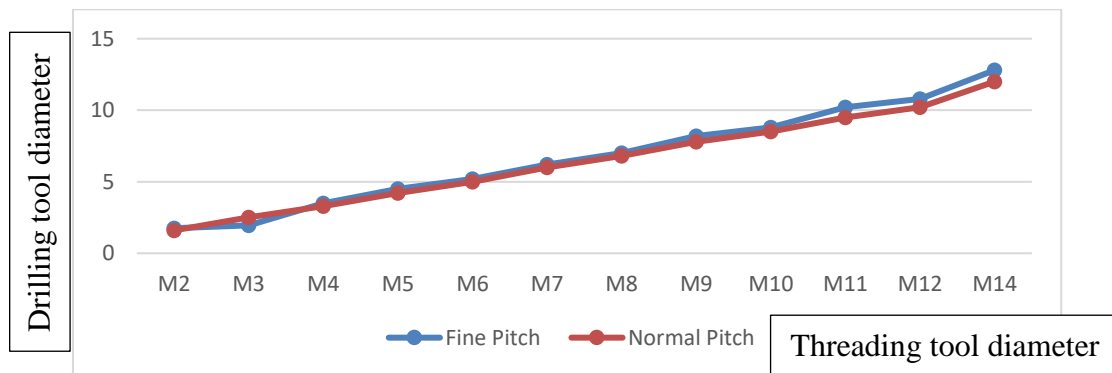

Figure 62 – Comparison between drilling diameter (Normal vs Fine threading tool)

Conclusive Analysis for the Threading Tool (both Fine and Normal pitch)

From this comparison topic, we ca get an exact conclusion for the threading tool, why because the tool diameter and drilling tool diameter both of them are belongs to the Pitch the threading tool. If you verify value in Figure 61, it’s easy to get an idea about the pitch of the different type of threading tool. My conclusion for this topic is both of the tools are almost same, but little difference in pitch of the tool. In company they prefer to use both the tools, it belongs to the work what they want to do.

6.3.5. Chamfer Tool

The chamfer tool has an intermediate edge between the two faces of a substances. The two-sided right faces are formed at 45-degree angle and it is used for protection and to prevent damage to the substance, otherwise remove the sharp edges. It is used to perform various types of works such as V-cuts, undercuts, welding preparations and often functional

performance at work ends, depending on the type of mechanism and the setup of the machine, these activities can be done in different ways. Usually depth of cutter and cutter width have a small relationship to depth of cutter diameter. This means that the higher cutting speed recommendations for small engagement should be used and feed for the teeth (blankets) can also be increased significantly its request for the surface finish. Using the same tool and inserts, the hole can be captured after the thread is completed. This is done using a circular grid path.

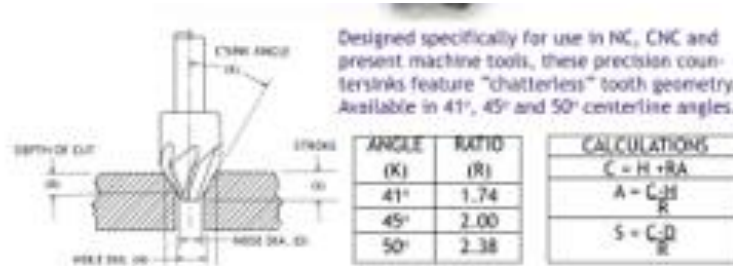

Figure 63 – Chamfer Tool

6.3.6. Gun drilling Tool

Normally, gun drilling tool is used to do the long holes for the cooling system. Already this topic is described in chapter 5. Now, this topic is to know the comparison chart for the Spindle rotation and Feed rate with Tool diameter.

In Figure 64: This graphical view is used to know the Spindle rotation values that used for every Gun drill. If we go through this graph means, we can understand one standard condition, (if the diameter goes higher the feed rate gets lower for example: if we compare with the $\varnothing 12$ and $\varnothing 16$ for $\varnothing 12$ – 1400 rpm and for $\varnothing 16$ – 1050 rpm).

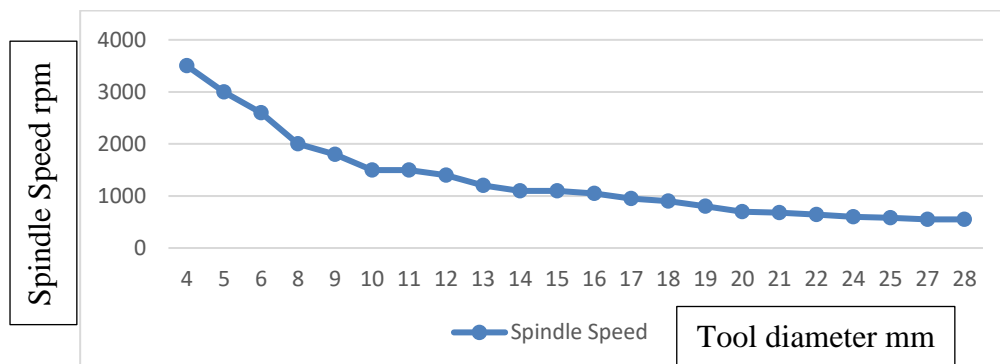

Figure 64 – General Parameters for gun drill tool (Tool diameter vs Spindle speed)

Figure 65 will be used to explain the variation level in Feed rate. As the same, tool diameter getting high the feed rate getting low, to avoid the tool breakage. Sometimes the feed rate is same while it compares to others.

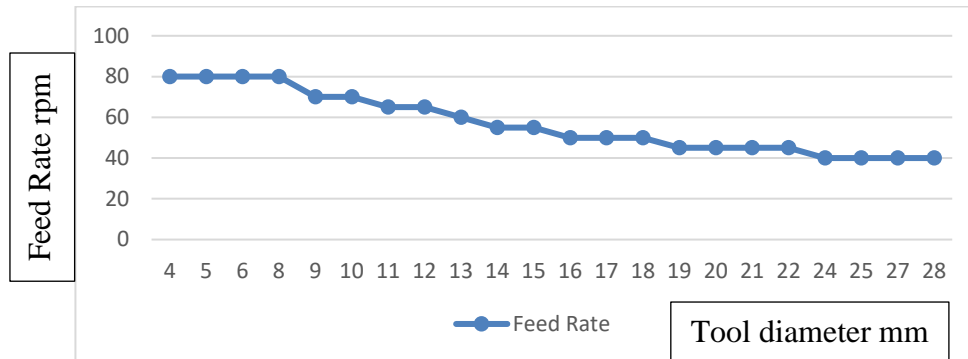

Figure 65 – General Parameters for gun drill tool (Tool diameter vs Feed Rate)

The Spindle rotation and feed rate may differ belong to the length of the tool and Material.

$$V_c = \frac{\pi d N}{1000} \text{ m/min}$$

$$N = \frac{V_c * 1000}{\pi d} \text{ m/min}$$

- Dc (d) - Drill Diameter
- P - Pressure
- S - Spindle Rotation
- Fz - Specific Cutting Force
- F - Feed Rate
- L - Length of the Tool
- Vc - Velocity of Cutting speed
- Tr - Torque Caused by Friction
- N - No of Rotation

Conclusion: From Figure 64 and Figure 65, we can get a clear conclusive result for the gun drilling tool Spindle Rotation and Feed rate, As described above for both Spindle rotation and Feed rate have same conclusion, If the tool diameter gets high means Spindle rotation and Feed rate needs to be low because due to avoid the tool breakage.

6.3.7. Conditions: 1 (1.1730/1.2344)

Main condition for this table, this will be going to compare the values to the Spindle rotation and Cutting Force for this material (1.1730/1.2344) with this length of the tool (300-400), because each parameter can differ with the length of the tool and material type.

Procedure

In this type of material is less hardness material, so we can use the 100% of value for the Spindle Rotation and Cutting Force. In the pressure is more are less same because if it makes a small hole with small diameter and small length means there is no difference in the pressure. In case if it needs to make a large hole with large diameter and small length means there is a little difference in the pressure (pressure needs to be low to avoid the breakage of tool and allows some time to take out the cutting steels that's why if the diameter of the tool get large the pressure get low and cutting force get high.

Parameters

For example: Usually we use diameter 12 for the oil and water circuit, so I going to explain the parameter for diameter 12 tool. And also, we can find a no of Tool rotation for each and every tool using with this formula. It shown below, Example parameter are shown in the Table 14

$$V_c = \frac{\pi d N}{1000} \text{ m/min}$$

$$N = \frac{V_c * 1000}{\pi d} \text{ m/min}$$

Description	Values
Diameter	12 mm
Pressure	12 bars
Spindle Rotation	1858 rpm
Cutting Force	0.035
Feed Rate	65 mm/min

Table 15 – Specified used parameters in 1.1730/1.2344

Diameter	Pressure	Spindle Rotation	Specific Cutting force	Feed Rate
D mm	P Bar	S Rpm	Fz N/mm ²	F mm/min
8	12	2787	0.025	70
9	12	2477	0.027	67
10	12	2229	0.03	67
11	12	2027	0.03	65
12	12	1858	0.035	61
14	10	1592	0.035	56
15	10	1486	0.035	52
19	10	1173	0.04	47

Length of the Tool L = 300 – 400 mm

Vc = 65 mm/min

Tr ≤ 1100 N/mm²

Table 16 – Parameters for Condition: 1 (1.1730/1.2344)

Remarks for Spindle Rotation vs Tool diameter

In this Graph, we are going to compare the values between the spindle rotation and Diameter of the tool. The main experience I realize with this graph is if the diameter gets high and then the spindle rotation gets low because of to reduce the tool breakage. The value is shown in the Figure 66

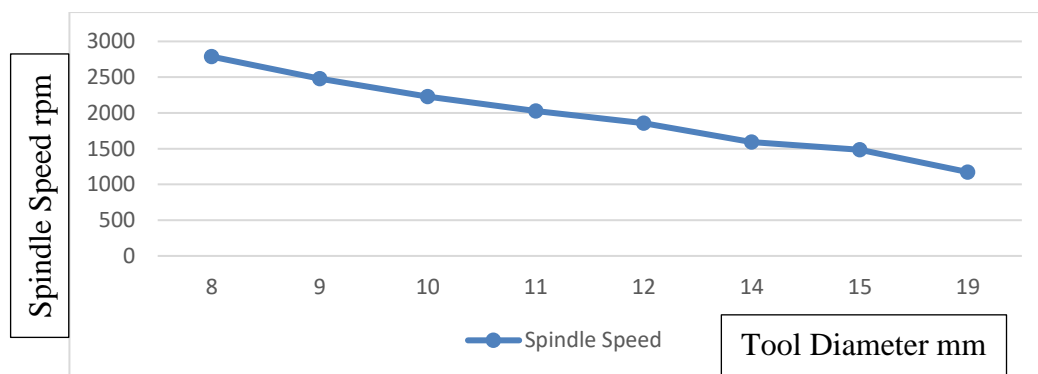

Figure 66 – Parameters for Spindle speed vs Tool diameter (Condition: 1)

Remarks for Spindle Rotation vs Tool diameter

In this graph mainly we discuss about the Cutting force. For the cutting is totally different from the Spindle rotation, because in spindle rotation if the tool diameter gets high means spindle rotation get low. But in cutting force if the tool diameter is high means the cutting force is also high that's the thing I explain in this graph. The values are shown below in Figure 67

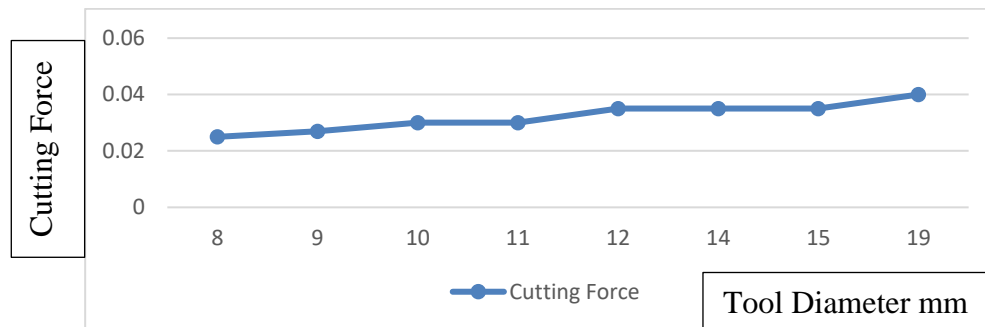

Figure 67 – Parameters for Cutting Force vs Tool diameter (Condition: 1)

Conclusion for Condition-1: In condition: 1, it belong to the gun drill tool in material (1.1730/1.2344). This material is a low hardness material, as mentioned earlier for the low hardness material have a lot of benefits, spindle rotation gets low, while the tool diameter gets high and Cutting force needs to be high, while the tool diameter gets high, it's easy to get a clear view in Figure 66 and Figure 67.

6.3.8. Conditions: 2 (1.2311/1.2738)

Main condition for this table, this will be going to compare the values between the Spindle rotation and Cutting Force for this material (1.2311/1.2738) with this length of the tool (500-600), because each parameter can differ with the length of the tool and material type.

Procedure

In this type of material is little hardness material when we compare to this material (1.1730/1.2344), so we can use the 90% of value for the Spindle Rotation and Cutting Force that I indicate in that table. The pressure is more are less same when it compares to the other type of material. But the condition is same (if it makes a small hole with small diameter and small length means there is no difference in the pressure, in case if it needs to make a large hole with large diameter and small length means there is a little difference in the pressure.

Pressure needs to be low to avoid the breakage of tool and allows some time to take out the cutting steels that's why if the diameter of the tool get large the pressure get low and cutting force get high).

Parameters

For example: Usually we use diameter 12 for the oil and water circuit, so I going to explain the parameter for diameter 12 tool. Example parameters are shown in Table 16.

Description	Values
Diameter	12 mm
Pressure	12 bars
Spindle Rotation	1672 rpm
Cutting Force	0.026
Feed Rate	43 mm/min

Table 17 – Specified used parameters for Condition: 2 (1.2311/1.2738)

Diameter	Pressure	Spindle Rotation	Specific Cutting force	Feed Rate
D mm	P Bar	S rpm	Fz N/mm^2	F mm/min
8	12	2508	0.02	50
9	12	2229	0.021	47
10	12	2006	0.022	44
11	12	1824	0.024	44
12	12	1672	0.026	43
14	10	1433	0.03	43
15	10	1338	0.03	10
19	10	1056	0.035	37
Length of the Tool L = 500 – 600 mm				
$V_c = 63 \text{ mm/min}$				
$Tr \leq 1100 \text{ N/mm}^2$				

Table 18 – Parameters for Condition: 2 (1.2311/1.2378)

Remarks for Spindle Rotation vs Tool diameter

In this Graph, we are going to compare the values between the spindle rotation and Diameter of the too. The main experience I realize with this graph all the conditions are same (if the diameter gets high and then the spindle rotation gets low because of to reduce the tool breakage). The value is shown in the Figure 68

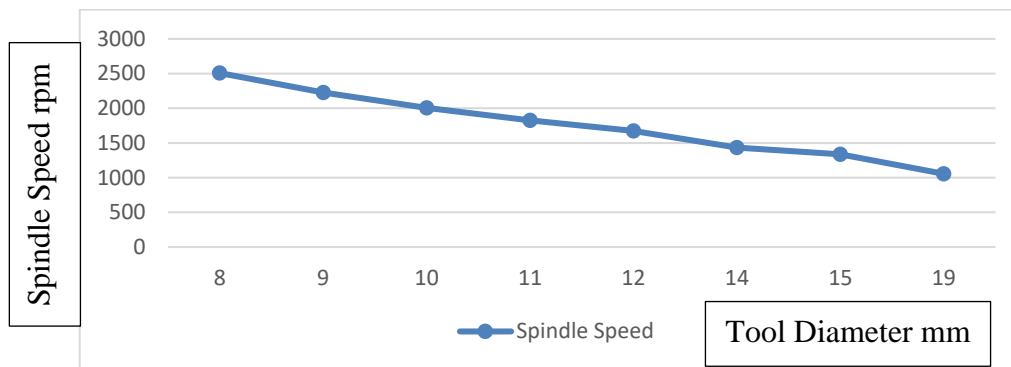

Figure 68 - Parameters for Spindle Rotation vs Tool diameter (Condition:2)

Remarks for Cutting Force vs Tool diameter

In this graph mainly we discuss about the Cutting force. For the cutting is totally different from the Spindle rotation, because in spindle rotation if the tool diameter gets high means spindle rotation get low. But in cutting force if the tool diameter is high means the cutting force is also high that's the thing I explain in this graph. The values are shown below in Figure 69

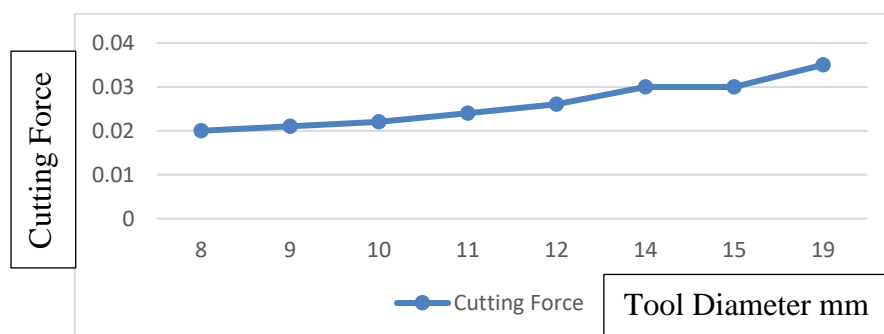

Figure 69 – Parameters for Cutting Force vs Tool diameter (Condition: 2)

Conclusion for Condition 2: (1.2311/1.2378) In this material, its not a too hard material but compare to the Condition: 1 Material hardness. This material is little hard always the Conclusion is same, if the material hardness is high means Spindle rotation gets low, while the tool diameter gets high and Cutting force needs to be high, while the tool diameter gets

high to avoid the collision between the steel and Tool. In Figure 68 and Figure 69, it has a clear a view the conclusion in graphical manner.

6.3.9. Condition: 3 (1.2711)

Main condition for this table is going to compare the values between the Spindle rotation and Cutting Force for this material (1.2711) with this length of the tool (700-1000), because each parameter can differ with the length of the tool and material type.

Procedure

In this type of material is a hardness material, so we can use the 70-80% of value for the Spindle Rotation and Cutting Force that I indicate in that table. The pressure is high because of the tool length and material type. But the condition is same (if it makes a small hole with small diameter and small length means there is no difference in the pressure, in case if it needs to make a large hole with large diameter and small length means there is a little difference in the pressure. Pressure needs to be low to avoid the breakage of tool and allows some time to take out the cutting steels that's why if the diameter of the tool get large the pressure get low and cutting force get high).

Parameters

For example: Usually we use diameter 12 for the oil and water circuit, so I going to explain the parameter for diameter 12 tool. Example parameters are shown in Table 18

Description	Values
Diameter	12 mm
Pressure	15 bars
Spindle Rotation	1672 rpm
Cutting Force	0.026
Feed Rate	43 mm/min

Table 19 - Specified used parameters for Condition: 3 (1.2711)

Diameter	Pressure	Spindle Rotation	Specific Cutting force	Feed Rate
D Mm	P Bar	S Rpm	Fz N/mm^2	F Mm
8	15	2189	0.01	21
9	15	1946	0.011	22
10	15	1752	0.0125	22
11	15	1592	0.014	22
12	15	1460	0.015	22
14	12	1251	0.0175	22
15	12	1168	0.018	21
19	12	922	0.02	18

Length of the Tool L = 700 – 1000 mm

$V_c = 55 \text{ mm/min}$

$Tr \leq 1400 \text{ N/mm}^2$

Table 20 - Parameters for Condition: 3 (1.2711)

Remarks for Spindle Rotation vs Tool diameter

In this Graph, we are going to compare the values between the spindle rotation and Diameter of the too. The main experience I realize with this graph all the conditions are same (if the diameter gets high and then the spindle rotation gets low because of to reduce the tool breakage). The value is shown in the Figure 70

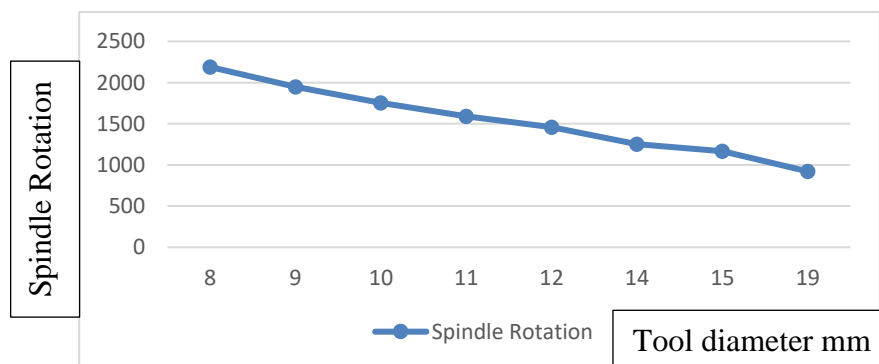

Figure 70 - Parameters for Spindle Rotation vs Tool diameter (Condition: 3)

Remarks for Cutting Force vs Tool diameter

In this graph mainly we discuss about the Cutting force. For the cutting is totally different from the Spindle rotation, because in spindle rotation if the tool diameter gets high means spindle rotation get low. But in cutting force if the tool diameter is high means the cutting force is also high that's the thing I explain in this graph. The values are shown below in Figure 71

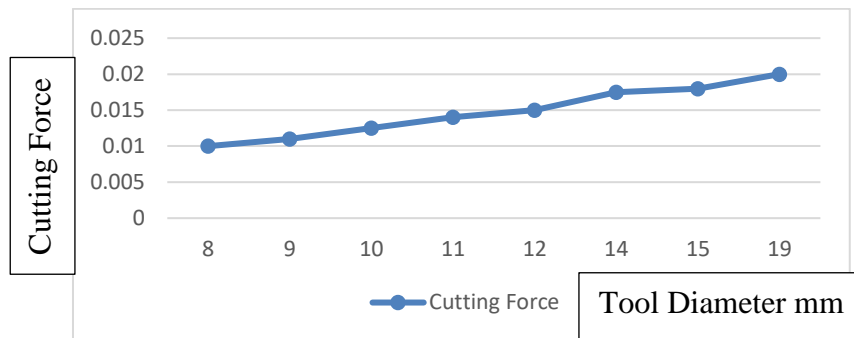

Figure 71 - Parameters for Cutting Force vs Tool diameter (Condition: 3)

Conclusion for Condition-3: (1.2711) This material is a high hardness material, as explained in before topic. The material have a high hardness means Spindle rotation gets low, while the tool diameter gets high. Cutting for gets high, ehile tool diameter gets high.

6.3.10. Condition: 4 (1.2714)

Main condition for this table is going to compare the values between the Spindle rotation and Cutting Force for this material (1.2714) with this length of the tool (1100-1500), because each parameter can differ with the length of the tool and material type.

Procedure

In this type of material is a very hardness material, so we can use the 60% of value for the Spindle Rotation and Cutting Force that I indicate in that table. The pressure is high because of the tool length and material type. But the condition is same (if it makes a small hole with small diameter and small length means there is no difference in the pressure, in case if it needs to make a large hole with large diameter and small length means there is a little difference in the pressure. Pressure needs to be low to avoid the breakage of tool and allows some time to take out the cutting steels that's why if the diameter of the tool get large the pressure get low and cutting force get high).

Parameters

For example: Usually we use diameter 12 for the oil and water circuit, so I going to explain the parameter for diameter 12 tool. Example parameters are shown in Table 20

Description	Values
Diameter	12 mm
Pressure	15 bars
Spindle Rotation	1380 rpm
Cutting Force	0.015
Feed Rate	21 mm/min

Table 21 - Specified used parameters for Condition: 4 (1.2714)

Diameter	Pressure	Spindle Rotation	Specific Cutting Force	Feed Rate
D mm	P bar	S Rpm	Fz N/mm ²	F mm/min
8	15	2070	0.01	21
9	15	1840	0.011	21
10	15	1656	0.0125	21
11	15	1506	0.014	21
12	15	1380	0.015	21
14	12	1183	0.0175	20
15	12	1104	0.018	20
19	12	872	0.02	17
Length of the Tool L = 1100 – 1500 mm				
Vc = 52 mm/min				
Tr ≤ 1400 N/mm ²				

Table 22 - Parameters for Condition: 4 (1.2714)

Remarks for Spindle Rotation vs Tool diameter

In this Graph, we are going to compare the values between the spindle rotation and Diameter of the too. The main experience I realize with this graph all the conditions are same (if the diameter gets high and then the spindle rotation gets low because of to reduce the tool breakage). The value is shown in the Figure 72

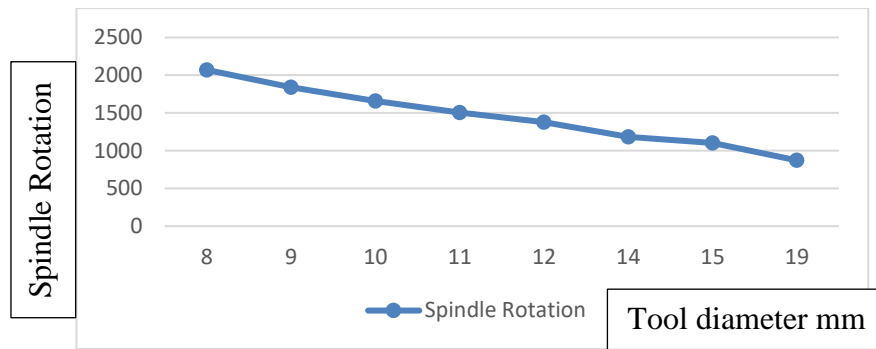

Figure 72 - Parameters for Spindle Rotation vs Tool diameter (Condition: 4)

Remarks for Cutting Force vs Tool diameter

In this graph mainly we discuss about the Cutting force. For the cutting is totally different from the Spindle rotation, because in spindle rotation if the tool diameter gets high means spindle rotation get low. But in cutting force if the tool diameter is high means the cutting force is also high that's the thing I explain in this graph. The values are shown below in Figure 73

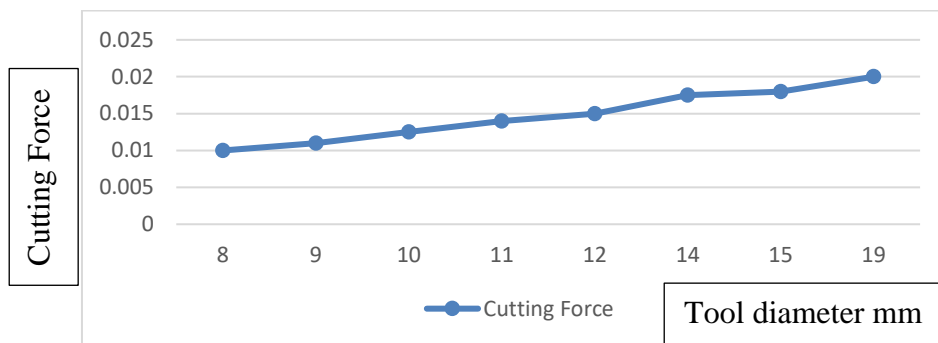

Figure 73 - Parameters for Cutting Force vs Tool diameter (Condition: 4)

Conclusion for Condition-4: (1.2714) This material has a more hardness, so always the condition is same. Material have a high hardness means spindle rotation gets low, while tool diameter gets high and Cutting force gets high, while the tool diameter gets high.

6.4. Case-Study about Different angle of Intersection Holes

This Case study is mainly depending upon the Different angle of Intersection holes and its properties. Normally, in gun drill have lot of intersection holes. But my case-study is Different types of inclination with intersection. In this case-study, I choose 4 different angle of inclination holes (Case-study: 1 belong to Straight intersection hole with 90°, Case-study: 2 Belong to Cross-intersection holes with 45°, Case-study: 3 belongs to Cross-intersection

holes with 30°, final case-study: 4 is belong to Cross-intersection hole with 10°-15°). In further topics we are going to see about this case-studies,

6.4.1. Case-study 1: (Straight intersection hole with 90°)

If the angle of hole is 90-degree, then the length of intersection hole will be smaller, the parameters of this tool followed with the normal feed rate and Spindle rotation (ex: F – 60% & S – 90%). As the intersection holes are smaller, there is a less tool wear rate. After drilling 6 to 8 holes, the tools should be grinded once in order to reduce the tool damage.

$$N = (55 \times 1000) / (3.14 \times 12)$$

$$N = 55000 / 37.68$$

$$N = 1460 \text{ m/min}$$

Analysis: This Case-study is about straight-intersection holes with 90° angle. In Figure 74, it easy to see where is located the entrance of the hole and where it gets intersect with another hole. Usually, if it is necessary to make a long hole with intersection means first, we need to finish the long hole, because to avoid the tool breakage. If we finish the long hole means already it have space, so it is easy to finish the other small holes. The used parameters are mentioned below in Table 22.

Possibilities to avoid tool breakage: In this Intersection hole have a two entrance, it's necessary to finish long entrance first, because after finishing long hole, it has space to finish the second entrance at the end.

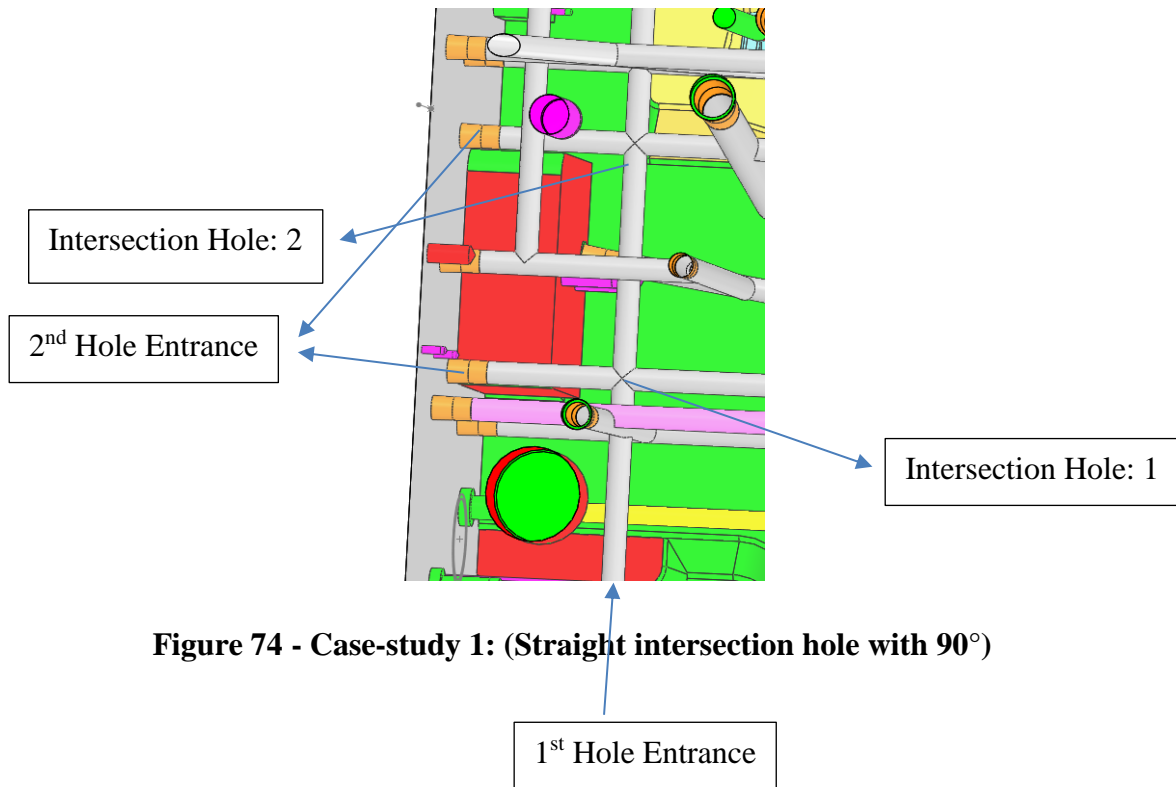

Figure 74 - Case-study 1: (Straight intersection hole with 90°)

Description	Values
Diameter	12 mm
Pressure	15 bars
Spindle Rotation	1460 rpm
Specific Cutting Force	0.015 N/mm^2
Feed Rate	22 mm/min
Length of the Tool	1000 mm
Material	1.2711
Velocity of cutting speed	55 mm/min
Number of the Rotation	1460 m/min

Table 23 – Parameters for Case-study: 1

Conclusion: For the material 1.2711 Straight-intersection hole of diameter 12 mm with the length of 1000 mm and the parameters are used in this study with the spindle rotation of 1460 rpm, cutting speed is 0.015 N/mm^2 , and the Feed rate is 22 mm/min, because in this this type steel hardness is high. This hole was performed during internship without any tool breakage and was not felt any difficulties to finish these holes because it just straight

intersection holes it has a more steel to cut, so there no possibilities to deviate from the hole. These parameters are suitable for this type of steel and the length of the tool. But sometimes the parameters get differ due to the tool cutting.

6.4.2. Case-study 2: (Cross intersection holes with 45°)

If the angle of hole is 45-degree, then the length of intersection hole will be little bit long and also it has more intersection holes, the parameters of this tool followed with the normal feed rate, but little bit differ because it has a more intersection holes (ex: F – 50% & S – 90%). As the intersection holes are not small, so there is a little tool wear rate compare to the 90-deegree holes. After drilling 5 holes, the tools should be grinded once in order to reduce the tool damage.

$$N = (52 \times 1000) / (3.14 \times 12)$$

$$N = 52000 / 37.68$$

$$N = 1380 \text{ m/min}$$

Analysis: This Case-study is belonging to the Cross-intersection holes with 45° angle. In Figure 75, it is easy to find where is located the intersection. As mention earlier, first it is necessary to finish the long hole and then continue to finish smaller one. While it enters the main intersection, place means it's necessary to reduce from normal feed to finish the holes more accurate. In table 23, are presented the used parameters.

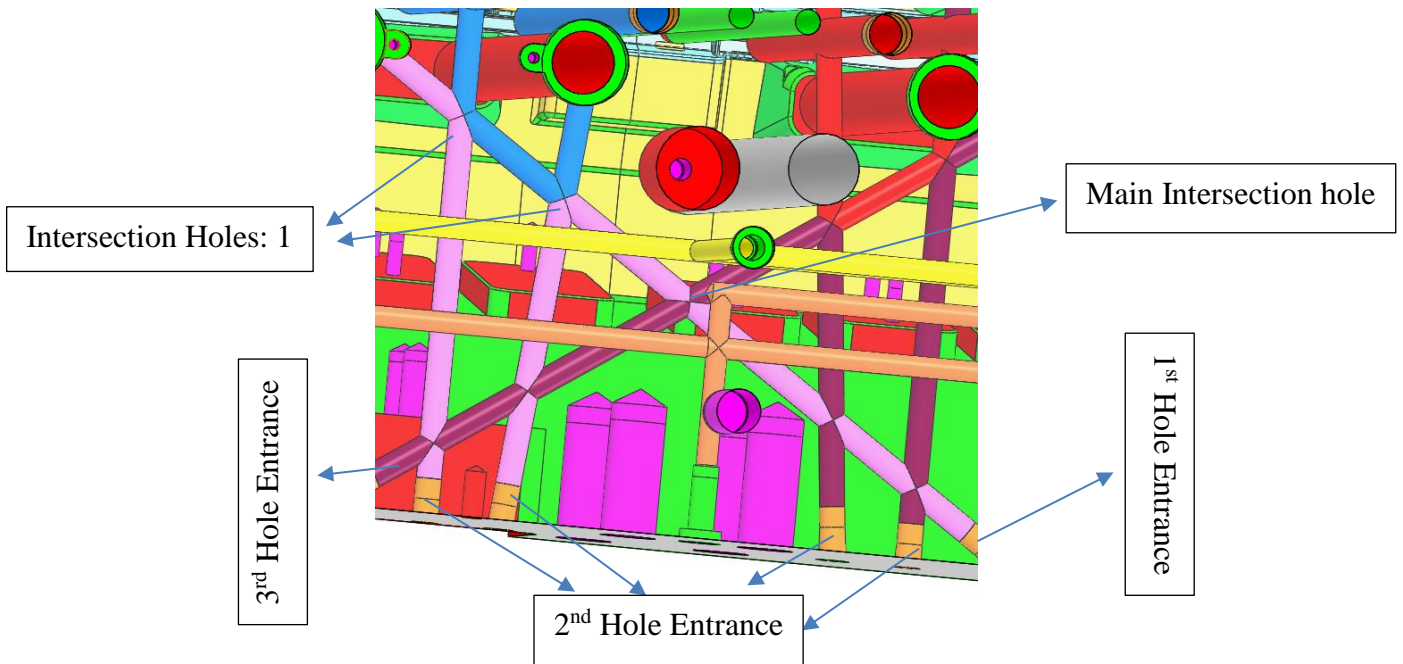

Figure 75 - Case-study 2: (Cross intersection holes with 45°)

Description	Value
Diameter	12 mm
Pressure	15 bars
Spindle Rotation	1380 rpm
Specific Cutting speed	$0.015 N/mm^2$
Feed Rate	21 mm/min
Length of the Tool	1200 mm
Material	1.2714
Velocity of Cutting speed	52 mm/min
Number of the Rotation	1380 m/min

Table 24 – Parameters for Case-study :2

Conclusions: In case-study 2, The material 1.2714 with the Cross-intersection hole (45°) of diameter 12 mm with the length of 1200mm and the parameters that are followed with the Spindle rotation of 1380 rpm and the cutting force is $0.015 N/mm^2$ with feed rate 21 mm/min, In this case-study 5 intersection are there, one long hole and 4 small intersection holes, the long hole is in 45° angle, first it's necessary to finish that long hole because after this long hole is finish they have a space to finish the small entrance hole. This is one of the possibilities to reduce the tool damage. As this type of material is very hard for this material

type, it's necessary to be careful with the tool deviation, because it have more number intersection holes are placed.

6.4.3. Case-study 3: (Cross intersection holes with 30°)

If the angle of hole is 30-degree, then the length of intersection hole will be long, the parameters of this tool is totally different compare to the 90 & 45- degree holes (ex: F – 40% & S – 85%). As the intersection holes are long, so there is a more tool wear rate compares to the 90-degree holes. After drilling 3-4 holes, the tools should be grinded once in order to reduce the tool damage.

$$N = (63 \times 1000) / (3.14 \times 12)$$

$$N = 63000 / 37.68$$

$$N = 1672 \text{ m/min}$$

Analysis: This analysis for the Cross-intersection hole with 30° angle. In Figure 76, it is easy to identify the intersection holes. In this case-study I face little difficulties to finish this hole. Because length of intersection is too high, and angle is also too high. For this kind of works it is necessary to be careful, there is a lot of possibilities to break the tool, while tool get enter into the intersection. Parameters are mentioned below in Table 24.

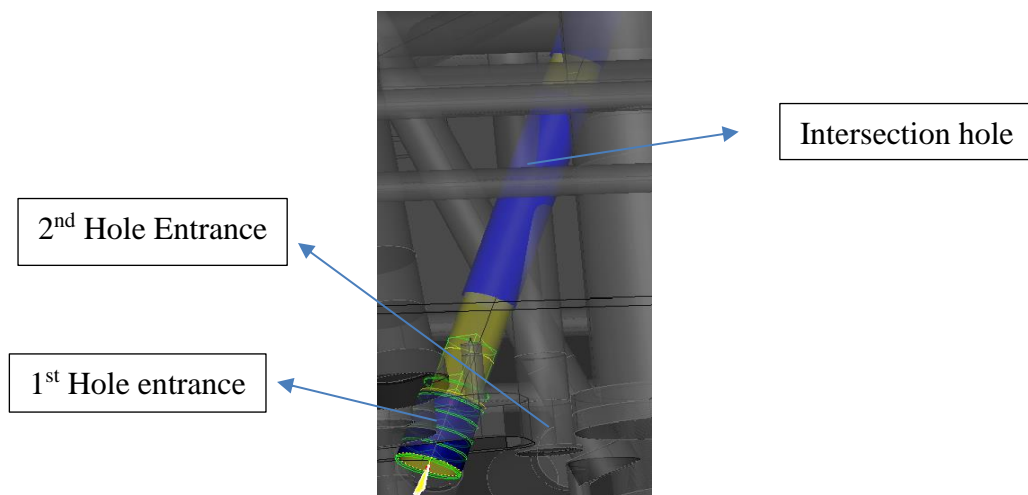

Figure 76 - Case-study 3: (Cross intersection hole with 30°)

Description	Values
Diameter	12 mm
Pressure	15 bars
Spindle Rotation	1672 rpm
Specific Cutting speed	0.026 N/mm^2
Feed Rate	43 mm/min
Length of the Tool	600 mm
Material	1.2311
Velocity of Cutting speed	63 mm/min
Number of the Rotation	1672 m/min

Table 25 - Parameters for Case-study:3

Conclusion: In Case-study 3, the material 1.2311, has been experimented with the Cross-intersection hole (30°) of diameter 12 mm with the length of 600 mm with parameters Spindle rotation of 1672 rpm and cutting force $0.026 N/mm^2$, and the feed rate 43 mm/min. As the material is lighter the above parameters have been followed. In this case-study, it has two holes with one intersection, but the intersection length is too high. In this condition its necessary to finish the inclination hole first, because in straight hole there is no possibilities to deviate to another hole. For that reason, intersection holes needs be finish first.

6.4.4. Case-study 4: (Cross intersection holes with 10° to 15°)

If the angle of hole is 10 to 15-degree, then the length of intersection hole will be too long, the parameters of this tool is totally different while it compares to normal feed rate (ex: DF – 35-45% & S – 75%). As the intersection holes are too long, so there is a more tool wear rate compares to the 90-deegree holes. It needs to grind each and every hole, to reduce the tool damage.

$$N = (65 \times 1000) / (3.14 \times 12)$$

$$N = 65000 / 37.68$$

$$N = 1725 \text{ m/min}$$

Analysis: This Case-Study to know about the Cross-intersection with 15° angle. In Figure 77, there is an exact view for this intersection hole. These Case-study is more difficult I face it, because in front of the tool head its necessary to put the gun drill front of the head, so it has a lot of possibilities to get broke the tool. But luckily, I finish this hole without any tool breakage. Feed and spindle rotation are literally half of the normal value. In Table 25, it has a parameter I used it for this hole.

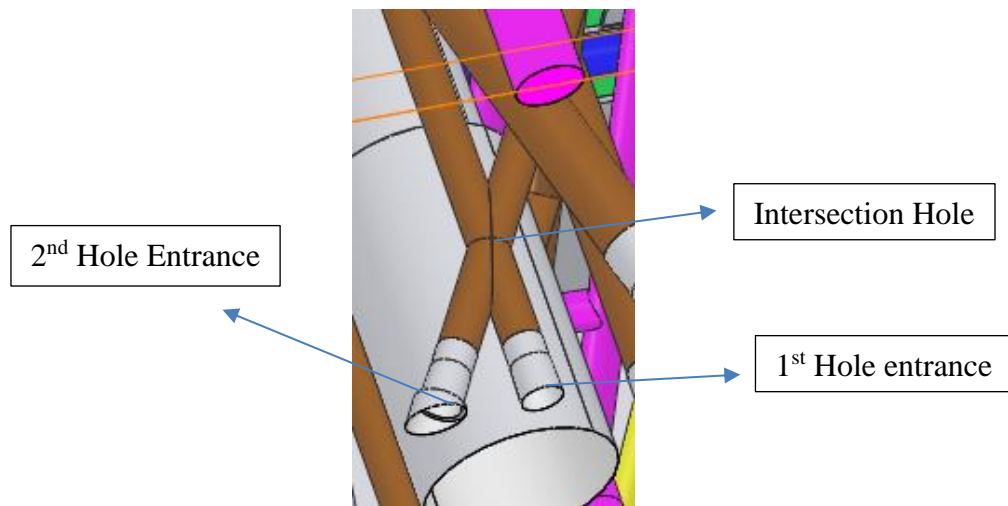

Figure 77 – Case-study 4: (Cross intersection holes with 10° to 15°)

Description	Values
Diameter	12 mm
Pressure	15 bars
Spindle Rotation	1725 rpm
Specific Cutting speed	0.035 N/mm^2
Feed Rate	65 mm/min
Length of Tool	1200 mm
Material	1.2344
Velocity of Cutting Speed	52 mm/min
Number of rotations	1725 m/min

Table 26 - Parameters for Case-study:4

Conclusion: Finally, the material 1.2344 with the cross-intersection hole (15°) of diameter 12 mm with the length of 1200 mm and the parameters that are followed with the spindle rotation of 1858 rpm and the cutting force is 0.035 N/mm^2 with feed rate 65 mm/min. As the material type is very lighter the above parameters haven been followed. In

this case-study, it has a two intersection holes. As I explain before, it's necessary to finish first inclination hole, because to create a space for the tool passage.

Disadvantages

Only drawback for this kind drill, if we have long with many intersections means the tool get affects. And also cooling rate of the tool is higher while we compare to the Normal drill.

Prevention

If we need to avoid the breakage of the tool while we make a large intersection holes means, there is some possibilities to avoid. First condition we need to grind the tool for each and every hole, second condition is we need to use the older tool with small tip tool.

6.4.5. Case-study 5: Feed Rate and Spindle Rotation analysis

Main motive of this Case-study is to compare the spindle rotation and cutting force with different kinds of materials.

With this experiment the same conclusion is proved (if the Diameter of the tool gets high means the spindle rotation gets low, because to avoid the breakage of the tool). But there is some advantages and disadvantages while the spindle rotation gets low. In Figure 78, it shows the different kinds of materials and its spindle rotation. If we came to the conclusion for this study means material is low means the Spindle rotation is high or if material is heavy the spindle rotation is low.

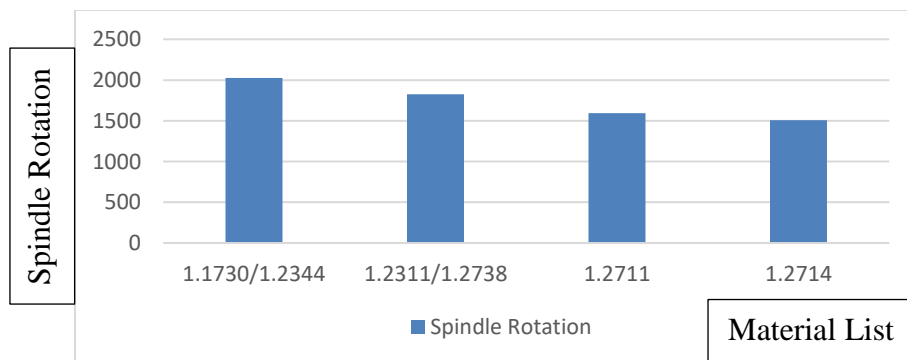

Figure 78 – Comparison chart between the Spindle rotation vs Different types of material list

From this Graph, for example I am to compare the values between the tool diameter 11 and its Spindle rotation with different kinds of material. The comparable values are shown in Table 26

Material list	Spindle Rotation Rpm
1.1730 / 1.2344	2027
1.2311 / 1.2738	1824
1.2711	1592
1.2714	1506

Table 27 – Comparison Table between the Spindle Rotation vs Different types of material list

Conclusion: In this topic, we can compare the value between the Spindle Rotation and different types of material, each and every material has a different parameter. If we use gun drilling tool for the different material means, its necessary to find the spindle rotation value for every material. (for example: I pick four different materials). I am going to conclude from this topic is, if we use the low hardness material means the spindle rotation gets high. If we use the high hardness material means the spindle rotation gets low to avoid the tool breakage. It’s easy to see comparison value in Figure 78.

Comparison value for the cutting force between the different kinds of material are shown in the Figure 79,

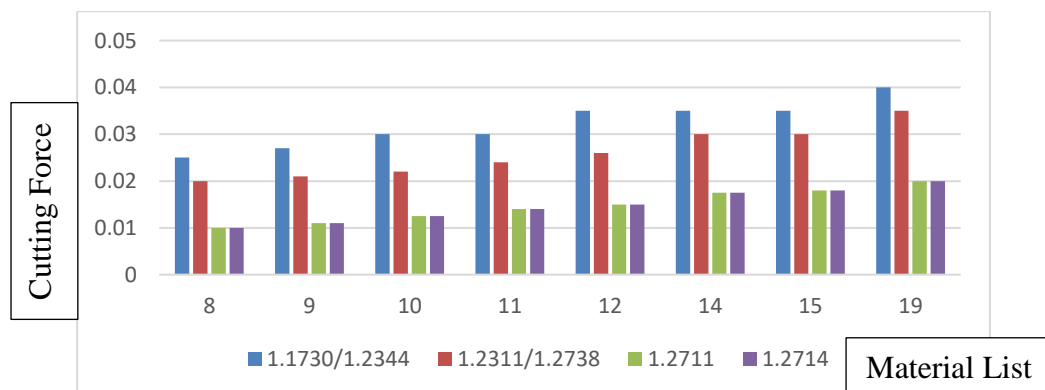

Figure 79 – Comparison chart between the Material list vs Cutting Force

Diameter	1.1730/1.2344	1.2311/1.2738	1.2711	1.2714
8	0.025	0.02	0.01	0.01
9	0.027	0.021	0.011	0.011
10	0.03	0.022	0.0125	0.0125
11	0.03	0.024	0.014	0.014
12	0.035	0.026	0.015	0.015
14	0.035	0.03	0.0175	0.0175
15	0.035	0.03	0.018	0.018
19	0.04	0.035	0.02	0.02

Table 28 – Comparison Table between the Material list vs Cutting Force

Conclusion: From this experiment, we can get the conclusion for the cutting force with the different material type. From figure 79, it's easy to get a graphical view for the cutting force. It's totally opposite from the spindle rotation, because for the cutting force is (if it uses the high diameter tool means the cutting force gets high, and if we use the low diameter tool means the cutting force is low), to avoid the collision between the tool and the Steel. And also, it depends upon the material hardness.

Advantages : To reduce the breakage of the tool.

Disadvantages : Time consuming is high, while we fix everything for the drilling process.

7. Conclusions

From these different types of case-study, I going to conclude the different possibilities. In case study 1, it has straight intersection hole with 90° angle for this hole have a more steel to cut while it gets intersect, so there is no problem for the tool and spindle rotation and cutting force.

From Study 2, In this hole are Cross intersection hole with 45° angle, according to this angle of hole it has 80% of steel is there to cut but its necessary to be careful while it intersect with another hole because sometimes the tool get deviate to another hole.

According to the Case study 3, This hole is cross intersection hole with 30° angle hole, this hole is little bit difficult because the hole has a little bit of steel is there while it enters into the intersection hole by reducing the spindle rotation and Feed rate from normal value, we can avoid the tool breakage.

In case study 4, this type of angle hole is difficult to made, because while it intersects to another hole at that time it makes a huge sound and get little bit vibrations because there is less 40% of steel is to cut, to avoid these things usually we reduce the Feed rate and spindle rotation value.

In final case, I just compare the value of Spindle rotation and Cutting force with different types of material.

Normally I use some strategy to finish these kinds of holes, first I prefer to finish the inclination hole, because after finishing the inclination hole it's easy to finish the straight holes. From those study, we can get a clear conclusion about the different angle intersection holes.

So, from my Internship training, I've got serious knowledge about the deep hole Drilling in Injection Moulding process. Tecnimoplás is such an industry where one of the most important things of any products is the dimensional accuracy. In terms of client request, we need to be fully accomplished from the tolerance. Therefore, frankly deep hole drilling in moulds should be used to produce a water & oil circuits and also in standard values and its

accurate dimension. I got a lot of information and experience from my internship about deep hole drilling in moulds. I have also been into the other department such as Milling, Erosion and Assembly for a few weeks. So, I have some knowledge about the milling, erosion and assembly department. The main thing I understand from my company's production is to be produce the moulds and solving the problem methodology in moulds. The way they solving the problem was a lesson for me. I've saw many problems and they try to solve the problems and that solutions come through finding the possibilities to solve the problem. Some of the problems were difficult to solve and some solutions were not able to solve it and they were resolved with a rational thinking or approach to complications with a close approach, which provided solutions. To understand about the Deep Hole Drilling method was pretty interesting as the machining was fast and clear. I got to know how to make a precise cut and drill are not possible in conventional machining are machined perfectly in drilling department. This is understood by checking the part that it is produce and comparing it with the design that provided by the customer. By identifying the flow of plastic and cooling system in the mould we will find several factors, by identifying the flow of plastic and cooling system in the mould we can rectify a number of factors by the flow, which will be rectify in production. So, I got the idea of how a flow has been adjusted. Furthermore, it is in the deep hole drilling department, which finds out how a water injection vacuum is prepared and understands what parameters are to be given priority when producing part advantages, defects and other information. From my entire Internship, I learned a lot of lessons and skills on moulding filed and also, I got a maturity to deal the problems with patience.

8. Bibliography

1. (TBT), T. (20 de July de 2019). *Single Lip gundrill*. Obtido de (TBT): <http://www.tbt.de/en/deep-hole-drilling-tool/single-lip-gundrill>
2. A, P. (1849). *Curiosities of Glass making*. London.
3. A.H.A. (November 11, 1959). *Insurance Contract*. Leiria: Diario de Vendas.
4. Broyles, K. (20 de July de 2019). *Kays Engineering INC*. Obtido de Kays Engineering: kbroyles@kays-dehoff.com
5. Chemheritage. (8 de july de 2005). *Chemheritage*. Obtido de <http://www.chemheritage.org>
6. chetverikov. (1965). *Metallorzhushchire Instrumentry*. Moscow: 5th edition.
7. Crescentind. (2015). *Important factor to Injection Moulding*. Obtido de Injection Moulding: [http://info.crescentind.com-factors-important to injection moulding](http://info.crescentind.com-factors-important-to-injection-moulding)
8. Dai, X. (20 de 19 de 2019). *Mechanical eng blog*. Obtido de Plastic injection cooling system: <http://mechanicalengblog.com>
9. Design, M. (2006). *Injection Mould design Technology end Engineering*.
10. G.A, A. (1, 1960). Machinery and Labour-saving devices in the Glass trade - Glass Technology. *Journal of the society of Glass technolgy*, 29-34.
11. G.A, A. (1, 1978). Machinery and Labour-Saving. *Journal of the Society of Glass Technology*, 105-108.
12. Gomes. (April 4,2000). Structure of the Mould. *Regiao de leiria*, 25.
13. Groover. (2007). Fundamental of Modern Manufacturing. *Fundamental of Modern Manufacturing*, 3.
14. Hardt, D. E. (19 November 2015). A review on the importance of surface coating of micro mould. *Journal of Micromechanical and microengineering*, Volume 26 Number 1.
15. Hume, I. (3, 1961). The Glass Wine bottle in Colonial virginia. *Journal of Glass Studies*, 63.

16. *Injection moulding Process*. (7 de 4 de 2011). Obtido de Mould Technology:
<http://www.mould-technology4all.blog.com>
17. Jonhannaber.F. (2008). *Injection moulding machines*. 378.
18. Lopes. F, A. (1958). *Satisfy the Technical demands*. Leiria: Diario de Vendas.
19. M.E, C. (june 24, 2004). A Origem da Industrial. *Os Plasticos em Portugal*, 34-35.
20. M.L. (1991). *SPI Plastics Eengineering*. Society of the plastic industry.
21. mould, J. (20 de 09 de 2019). *Three plate Moulding*. Obtido de Jave mould:
<http://mouldingmould.com>
22. Moulding., H. (2011). *Injection Moulding machine*. 33.
23. Murti. (2010). *Simulation and Analysis of Injection Moulding*. Arcada University. Finland:
Arcada University.
24. Parts, M. S. (10 de May de 2019). *Injection Moulding Parts*. Obtido de
<http://www.sinotech.com/resources/tutorial/injection Moulding Parts>
25. Parts, S. (10-05-2019). *Injection Moulding Parts*. <http://www.sinotech.com/resourses>.
26. R.J, C. (1560-1640). English glass used in England. *Developement of English glass making*,
228-32.
27. Ryan, V. (20 de 09 de 2019). *Injection Moulding for Plastic*. Obtido de Techonolgy student:
<http://www.technologystudent.com>
28. Shoemaker. (2006). *Madflow design guide*. Munchen, Hanser Verlage: A resource for Plastic
engineers.
29. SRL, K. (20 de 2019 de 2019)). *REM Industries*. Obtido de (<http://fastmill.it/pt/products>)
30. Stelray. (5 de 9 de 2017). *Injection Moulding part design Hot runners*. Obtido de Injection
Moulding part design Hot runners: <http://www.stelray.com>
31. Sullc, S. (20 de 09 de 2019). *Single Lip Gundrill*. Obtido de Single Lip gundrill:
<http://www.star.su.com>
32. Sullu, S. (20 de 09 de 2019). *Double Lip Gundrill*. Obtido de Double Lip Gundrill:
<http://www.star.su.com>

33. Sun.Y.F, L. N. (2004). Design and FEM analysisof the milled groove insert method for cooling of plastic injection moulding. *Journal of Advanced manufactured and Technology*, 715-726.
34. Talbot. (8, 1974). The Evolution of Glass bottles for Carbonated drinks. *Post-Medieval Archaeology*, 29-62.
35. TIEFBOHRTECHNIK. (20 de july de 20-07-2019). *Double Lip Gundrill*. Obtido de (TBT): <http://www.tbt.de/en/deep-hole-drilling-tool/double-lip-gundrill>
36. Turner, W. (6, 1922). The British Glass Industry. *Journal of the Society of Glass Technology*, 100.
37. Turner, W. (6,1922). The British Glass Industry. *Journal of the Society of Glass Technology*, 129.
38. UNIDIG. (20 de July de 2019). *BTA deep hole drilling*. Obtido de <http://www.unidig.com/products and technology/tooling/bta-deep-hole-drills/>
39. UNISIG. (15-05-2019). www.unisig.com. USA.
40. Wheatley, H. (October, 1663). New bottles. *The Diary of Samuel Pepys*, 23.

