



## **Curriculum Internship Report**

**(02/11/2016 – 02/08/2017)**

**Master's in Product Design Engineering**



**Submitted by:**

**Naveen Bharadwaj D N**

**Student ID: 2151914**

**Department of Mechanical Engineering**

**Polytechnic Institute of Leiria, IPL**

Leiria, August, 2017





## **Curriculum Internship Report**

**(02/11/2016 – 02/08/2017)**

**Master´s in Product Design Engineering**



**Submitted by:**

**Naveen Bharadwaj D N**

Master´s internship carried out under the supervision of Prof. Carlos Capela and Prof. Henrique Amorim Almeida, professors of the School of Technology and Management at polytechnic Institute of Leiria.

Leiria, August, 2017



## **Acknowledgement**

I am very thankful to **Electrofer Grupo** for having given me an opportunity to undertake my curriculum internship at their prestigious organization. It was a very good learning experience for me , so I could get exposed to an industry that involved variety of unique construction practices and challenges. I would like to convey my heartfelt thanks to **Mr. Jose G.M. Gregorio**, Managing Director and **Mrs. Sara Verde**, Director Human Resources who heartily welcomed me for the internship. I express my deep sense of gratitude to **Mr. Joao Marques**, Director Quality Department, who was the supervisor of my intership and the one who guided me through out my internship and who provided sincere supervision during the works of my internship. I would also like to thank all the department heads of Electrofer Grupo for training me by spending their valuable time and by giving me good guidance during my internship programme.

I owe my whole hearted thanks to all the staff of Electrofer Grupo for being so helpful during the phase of my internship.

I want to give special thanks to **Prof. Carlos Capela** and **Prof. Henrique Amorim Almeida**, proferrors of the School of Technology and Management at polytechnic Institute of Leiria for their required support and encouragement.

I am also thankful to my parents who have always been as a source of inspiration and motivation for me.

I hope that I can build upon the experience and knowledge that I have gained and make a valuable contribution towards the Enterprise in coming future.

Last but not the least, I have tried my heart and soul to write the report accurately, however there might be some errors and impracticle mistakes due to my aptitude and time constraints. In this regard, I request your good-self to seek your kind consideration as I am in the process of learning.



## **Resumo**

O relatório de estágio é um amplo espectro dos trabalhos de estágio em que tento explicar a experiência da minha empresa de hospedagem de estágio (Electrofer Grupo). Este relatório é amplamente construído com aspectos teóricos e práticos do trabalho de construção que é realizado na organização.

Depois de ter um curso de curso intensivo, procurei ter um estágio em uma empresa de construção metálica para obter experiência prática e familiaridade com a construção de estruturas de aço. Para o segundo ano de Mestrado em Engenharia de Design de Produto, realizei estágio no Electrofer Grupo. Esta empresa tem uma importância fundamental na construção de obras de aço e tem uma das maiores unidades de produção em todo o país que funciona em várias regiões para produzir estruturas de aço.

Este relatório consiste em muitos capítulos que são escritos de acordo com cada estágio do meu estágio. A primeira fase do meu estágio iniciou-se no departamento de preparação e posteriormente foi seguida por Qualidade, Produção, Pintura, Gestão Comercial e de Construção.

Por isso, este relatório é uma coleção de todas as obras de diferentes departamentos envolvidos na produção de aço. No que diz respeito à minha preocupação com este estágio, ganhei muita visão sobre como usar o conhecimento teórico aplicável em conformidades práticas.

Tenho certeza de que, com essas habilidades profissionais com abordagem teórica e prática, poderei usá-las para ganhar meu potencial para realizar trabalhos industriais com os aspectos de qualidade.



## **Abstract**

The internship report is a broad spectrum of the works of internship in which I try to explain the experience of my internship hosting company (Electrofer Grupo). This report is broadly constructed with theoretical and practical aspects of the constructional work that is carried out in the organization.

After having intensive course work, I looked upon to have internship in a metallic construction company in order to get practical experience and familiarity with the construction of steel structures. For the second year of Master's Degree in Product Design Engineering I took internship in Electrofer Grupo. This company owes a pivotal importance in the construction of Steel works and has one of the largest production units in whole of Portugal functioning in various regions to produce steel structures.

This report consists of many chapters that are written according to each stages of my internship. The first phase of my internship started in the department of preparation and later it was followed by Quality, Production, Painting, Commercial and Construction Management.

Hence, this report is a collection of all the works of different departments that is involved in the production of steel works. As far as my concern with this internship, I gained much insight into how to make use of theoretical knowledge applicable in practical conformities.

I am sure that with these professional skills with theoretical and practical approach, I will be able to use them to gain my potential towards to carry out industrial works with the aspects of quality.

**Keywords:** Metallic Constructions, Fabrication Process, Quality



## List of Figures

Figure 1: Electrofer General Organization Structure .....	4
Figure 2: Grid dialog box .....	8
Figure 3: Reference model imported from 2D software .....	9
Figure 4: Grid values for modelling silos and it's structures .....	10
Figure 5: Detailing for pad footings .....	10
Figure 6: Footings for silos and columns .....	11
Figure 7: Column properties dialog box .....	11
Figure 8: Silos and its structures .....	12
Figure 9: Placement of beams over the silos .....	12
Figure 10: Construction of slabs on the beams .....	13
Figure 11: Structure modelled to assembled with the structure of silos.....	13
Figure 12: Change Phase1 to Model1 .....	14
Figure 13: Assembly selection dialog box .....	14
Figure 14: The completed model of silos and it's structures .....	15
Figure 15: Exercise for placement of bolts .....	15
Figure 16: Grid Values to model a Steel container .....	17
Figure 17: Top view of grid for Steel container .....	17
Figure 18: Stiffeners.....	18
Figure 19: Cuts for welds .....	18
Figure 20: Completed model of Steel container.....	19
Figure 21: Grid values for Bridge .....	20
Figure 22: Base of the Bridge structure .....	20
Figure 23: Shoulders for supporting pedestrian's passage .....	21
Figure 24: Barriers attached to the shoulder .....	21
Figure 25: : Side view of the arch for bridge .....	22
Figure 26: The surface view of the arch.....	22
Figure 27: Completed model of the bridge .....	23
Figure 28: Beam properties dialog box to name prefixes .....	23
Figure 29: Numbering of the parts .....	24
Figure 30: Parts converted to 2D drawing for manufacturing.....	24
Figure 31: ITP reference document for steel structures .....	26
Figure 32: ITP reference document for steel structures .....	27
Figure 33: ITP reference document for steel structures .....	27
Figure 34: Recommended matrix for determination of execution classes .....	29
Figure 35: Metal Active Gas welding, process 135 .....	29
Figure 36: Flux Cored Arc Welding, process 136 .....	30
Figure 37: Submerged Arc Welding, process 121 .....	30
Figure 38: Drawn arc stud welding with ceramic ferrule, process 783.....	31
Figure 39: Shielded Metal Arc Welding, process 111 .....	31
Figure 40: Various positions that a welding can be made .....	32
Figure 41: Visual inspection and major welding defects chart .....	33
Figure 42: Fillet welding terms .....	34

Figure 43: Digital throat weld measuring gauge .....	34
Figure 44: Leg-length measuring cam type gauge .....	34
Figure 45: Ultrasonic test equipment .....	35
Figure 46: Couplant applied on the weld part .....	36
Figure 47: Magnetic particle testing.....	36
Figure 48: Arrangement of plates for CNC cut.....	39
Figure 49: Plasma cut.....	40
Figure 50: Section plate cutting machine .....	41
Figure 51: Drilling machine .....	41
Figure 52: Bending machine .....	42
Figure 53: Flux cored arc welding .....	43
Figure 54: Flux cored arc welding machine.....	43
Figure 55: Submerged Arc welding process .....	44
Figure 56: Shielded metal arc welding process.....	44
Figure 57: Hot dip galvanizing process .....	46
Figure 58: Uniform corrosion on steel .....	48
Figure 59: Crevice corrosion.....	48
Figure 60: Pitting corrosion .....	49
Figure 61: Erosion corrosion in a tube wall .....	50
Figure 62: Corrosion products will have volumes higher than steel and cause deformation .....	51
Figure 63: Sharp edges to be rounded to obtain uniform and thick paint coat thickness .....	51
Figure 64: Right angled bends to be eliminated to avoid turbulence which may cause corrosion .....	51
Figure 65: Cathodic protection .....	52
Figure 66: Peeling of paint .....	56
Figure 67: Saponification .....	57
Figure 68: Blistering due to entrapped air or solvents in the coating .....	57
Figure 69: Formation of craters .....	58
Figure 70: Cracking of paints .....	58
Figure 71: Solvents disappearing from the spray before it reaches the surface .....	59
Figure 72: Orange peel .....	59
Figure 73: Copy of a daily log report.....	65
Figure 74: Wet film thickness measuring gauge .....	68
Figure 75: Wheel gauge to measure wet film thickness .....	69
Figure 76: Magnetic induction instrument .....	70
Figure 77: Magnetic pull off instrument for measuring dry film thickness .....	70
Figure 78: Structural Organization of Commercial department in Electrofer Grupo .....	72
Figure 79: Activities of commercial management .....	73
Figure 80: Characteristics of buyer seller relationships .....	74
Figure 81: Budget preparation flow chart .....	75
Figure 82: Cash flow budget analysis (quarterly) .....	76
Figure 83: Sample cost estimation for site, footings and foundations .....	77
Figure 84: Construction Management organizational structure .....	78
Figure 85: Sample schedule for an assessment plan .....	80

Figure 86: Steps involved in collecting datas, choosing methods and planning for data processing and analysis .....	81
Figure 87: Flowchart for the developement of a project .....	83
Figure 88: Factors affecting initial cost of the project .....	84
Figure 89: Construction budget.....	85



## List of Tables

<i>Table 1: Atmospheric corrosivity categories and their influence on typical environments</i> .....	60
<i>Table 2: Daily record for paint applications</i> .....	64



## List of Symbols

CAD	Computer Aided Design
QA	Quality Assurance
QC	Quality Control
ITP	Inspection and Test Plan
CEN	European Committee for Standardization
CENELEC	European Committee for Electrotechnical Standardization
ANSI	American Institute of Standard Institute
AWS	American Welding Society
NDT	Non-Destructive Testing
ISO	International Organization for Standards
SC	Service Category
PC	Production Category
CC	Consequence Class
EXC	Execution Class
MAG	Metal Active Gas
GMAW	Gas Metal Arc Welding
MIG	Metal Inert Gas
CO2	Carbon di Oxide
FCAW	Flux Cored Arc Welding
SAW	Submerged Arc Welding
SMAW	Shielded Metal Arc Welding
MHz	Mega Hertz
CAM	Computer Aided Machining
CNC	Computer Numeric Control
PVC	Pigment Volume Concentration

Sa	Sand Blasting
St	Hand and Power Tool Cleaning
F1	Flame Cleaning
BOQ	Bill of Quantities
CM	Construction Management

# Table of Contents

Acknowledgement.....	v
Resumo.....	vii
Abstract .....	ix
List of Figures .....	xi
List of Tables.....	xv
List of Symbols .....	xvii
Table of Contents .....	xix
1. Introduction .....	1
1.1. Sections of the company I have been working .....	1
2. About the Organization .....	3
2.1. Structure of the organization .....	4
2.2. Quality Policy.....	5
2.3. Environment, Health and Safety policy .....	5
2.4. HR Policy .....	5
2.5. Work Culture.....	5
2.6. Vision .....	6
2.7. Mission.....	6
3. Department of Preparation .....	7
3.1. Modelling with Tekla Structures.....	7
3.2. Training on Tekla Structures.....	7
3.3. Experience while working on Tekla Structures: .....	9
3.4. Placement of bolts .....	15
3.5. Working on Project 1(Steel Container):.....	16
3.6 Working on Project 2 (Bridge).....	19
3.7. Drawing:.....	23
4. Department of Quality.....	25
4.1. Quality Testing.....	25
4.2. Role of quality assurance manager:.....	25
4.4. Welding Process used in Electrofer: .....	29
4.5. Welding Positions: .....	31
4.6. Welding Inspection: .....	32
4.7. Ultrasonic inspection.....	35
4.8. Magnetic particle inspection .....	36
5. Department of Production .....	37
5.1. Production .....	37

5.2. Production procedure: .....	38
5.2.1 Design for economic production-.....	38
5.2.2 Cut optimization.....	38
5.2.3 Fabrication process:.....	40
6. Department of painting.....	47
6.1. Introduction to Painting:.....	47
6.2. Corrosion:.....	47
6.3. Protection against corrosion.....	50
6.4. Paint coatings.....	53
6.5. Composition of paint.....	53
6.6. Types of Paints.....	54
6.7. Paint coating failures.....	55
6.8. Painting Standards.....	59
6.9. Procedures and documentations.....	62
6.10. Inspection.....	66
7. Department of Commercial.....	72
7.1. Commercial Management.....	72
7.2. Commercial Relationships.....	73
7.3. Role of budgeting in Managements planning.....	75
7.4. Understanding cash flow.....	76
7.5. Estimation in Construction Industry.....	77
8. Department of Construction Project Management.....	78
8.1. Construction Management (CM).....	78
8.2. Construction Management chart.....	78
8.3. Mission of Construction Management department in Electrofer.....	78
8.4. Objectives of the department.....	78
8.5. Assessment plan.....	79
8.6. Developement of a Project by Project Manager.....	82
8.7. Budgeting for the assessment.....	83
8.8. Project Execution.....	85
9. Conclusion.....	86
10. Bibliography.....	88



# 1. Introduction

Since, I finished first year of my Master's in Product Design Engineering. I wished to take up Internship for the second year works. So, I was searching for an internship in the companies that deals with Energy conversion or industry that deals with the construction of metallic components. When I was searching internships in these fields I was not able to search one that suits my área of interest. Later, I requested my Professors to find an internship for me in any of these fields. Later, my Professors explained me about Electrofer Grupo that deals with construction of Metallic components and surface treatment.

On later stages, the company accepted me to do internship in various áreas that existed in the company. I really liked the work culture of this enterprise; everyone encouraged me to learn different strategies of applications that existed in their department. All the doubts I had were clearly explained by the representatives of every department without hesitation. The Director of Quality department and my internship supervisor Mr. Joao Marques gave me in-depth knowledge of welds and standards that are used to produce construction materials. In similar fashion, all the representatives of different departments gave an insight clear idea about the information about the functions and the importance of their department that is responsible to carry out overall activities to achieve organizational goals. All the information that I collected from every department and the works that I have carried out during my internship are explained in my report.

In this, I try to explain my nine months work that I progressed in different departments of my internship hosting company (Electrofer Grupo). The report is broadly constructed with theoretical and practical aspects of the constructional work that is carried out in the organization. This report consists of many chapters that is written according to each stages of my internship.

## 1.1. Sections of the company I had been working

The first phase of my internship started at the department of preparation and later it was followed by Quality, Production, Painting, Commercial and Construction Management.

- Department of preparation: In this department, training was given on using Tekla Structures, a building information modelling software. In the beginning stage, I was taught how to visualize drawings and plot them on the software. After learning the software, I could freely experiment designing different steel structures and in the first chapter, I have clearly discussed the things that I have learnt in this department.
- Department of Quality: In this department, training was given to formulate inspection and test plans and how to execute them for producing quality products. Thorough training was given to visualize welds according to European and American standards. In second chapter, all the details that is related to welding and producing constructional structures according to the European and American standards are discussed.

- Department of Production: In the department of production, training was given on all the productional aspects of constructional structures.
- Department of Painting: In the department of painting, theoretical aspects of different rust grades of steel and protection of steel from corrosion were explained. Selection of paints according to the standards for corrosion protection and environment were explained.
- Department of Commercial: The relationship management with the customers were thought. Suituational analysis of marketing plan, budgeting and tender estimation was thought.

Department of Construction Management: In this department, selection of materials,

## 2. About the Organization

Electrofer Grupo is the biggest legacy of a Portuguese Entrepreneur, Mr. José Gregório e Joaquim Fernandes, who built a heritage that facilitates Metallic Constructional Works. Electrofer Grupo is a world class organization which has successfully erected beautiful complex structures all over the world and now is a leader in construction of steel structures. Their erections included pedestrian bridges, steel bridges, railway bridges, steel stanchions, steel structures, communication towers, slab support structures, modular housing projects, auxiliary towers, structures for swimming pools, factories, logistic centres, shopping malls, biodiesel power plants, roads and railway support equipments, football stadiums, acoustic barriers etc. All these erections were so successful because of the perseverance and dedication towards the quality of work.



**Address:** Rua Casal de Lebre N°45, Apart. 605

2430-446 Marinha grande

Portugal

**Telephone:** +351- 244 570 500

+351-244 570 509

Electrofer Grupo was founded in the year 1985 with an objective to produce metal structures to electricity networks for mid and low voltages. Later, Electrofer expanded their business and they expanded their business towards public works and anti-corrosion protection. By this, Electrofer II and Electrofer IV were born. Electrofer II produce steel structures and Electrofer IV deals with surface treatment. These two companies join together to make services to Electrofer Grupo.

Electrofer Grupo is EN ISO 9001 Quality Certified Company and now Electrofer has launched Execution Class IV for the construction of special structures.

## 2.1. Structure of the organization

# Organograma Grupo Electrofer

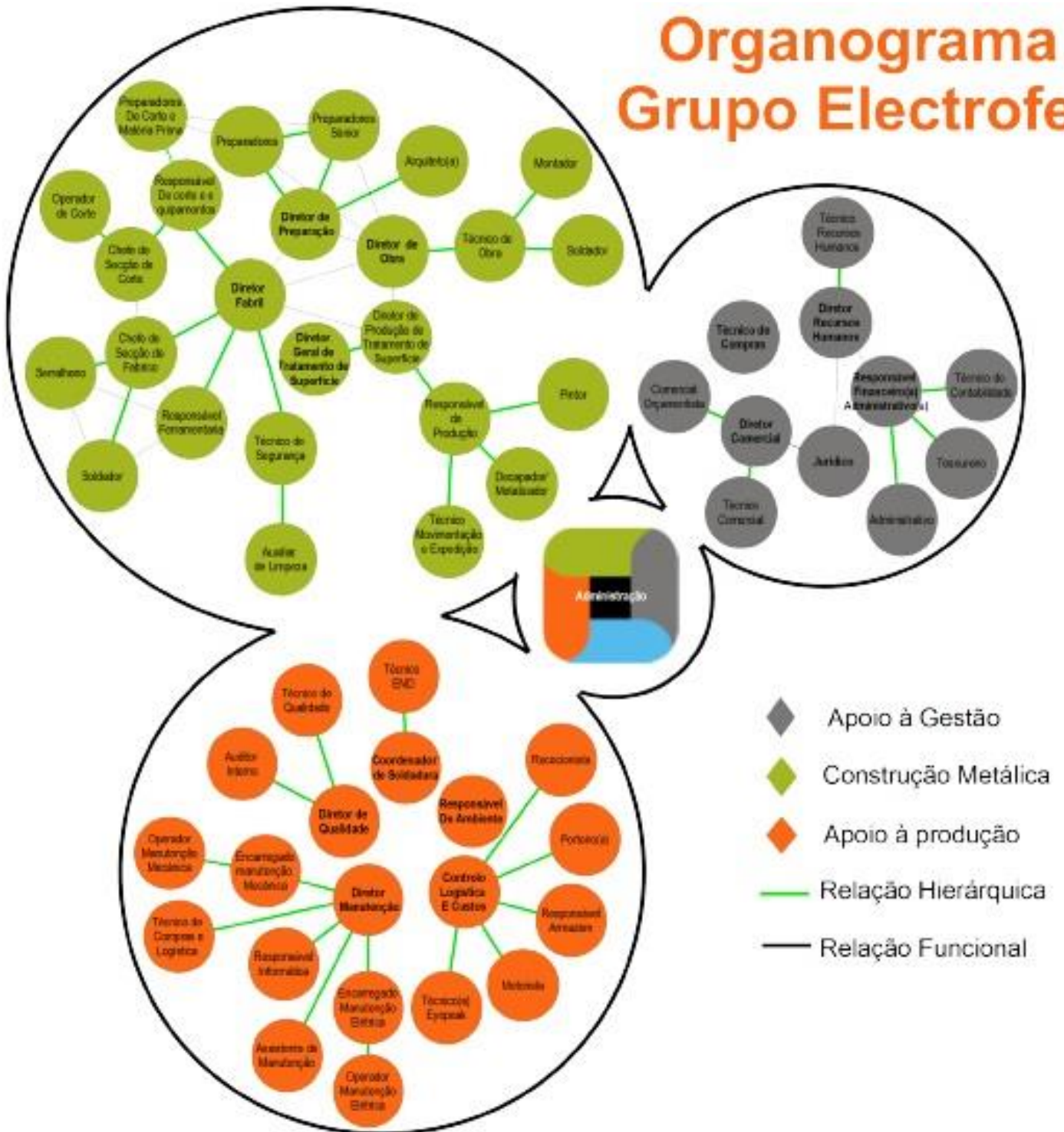

Figure 1: Electrofer General Organization Structure (Electrofer Group, 2017)

## **2.2. Quality Policy**

Electrofer quality policy has the ultimate goal of satisfying their customers. Electrofer's quality policies are defined as:

- Careful customer care
- Effective and efficient work management
- Meet customer requirements
- Have motivated and satisfied employees

Electrofer quality policy explains that these four points are the subject of a continuous process of evaluation and improvement.

## **2.3. Environment, Health and Safety policy**

At Electrofer Grupo, health and safety are given with the highest priority. The policy enunciated by the management of Electrofer lays emphasis on environment, health and safety through structured approaches and well defined practices. Electrofer's Environment, Health and Safety objectives include:

- Ensure working conditions that safeguard the safety and physical and mental health of workers.
- Prevent accidents at work.
- Develop the technical conditions that ensure the application of measures to prevent accidents at work.
- Inform and train workers in the field of occupational safety and health.
- Managing stocks and purchasing personal protective equipment.
- Manage cleaning and building maintenance
- Execution of policies to prevent occupational risks;
- Compliance with legislation on occupational safety and health.

## **2.4. HR Policy**

We at Electrofer Grupo believe that people are our most valuable resource and play a vital role in helping us realize our vision. We are committed to:

- Manage the difference between the expectations of employees and the reality in wages and employment stability.
- Ensure compliance with all processes that affect you, in a precise and timely manner
- Fulfill all your goals efficiently, with the least waste of time and money.
- To answer all the doubts of employees who fit into the field of human resources.
- Anticipate the needs of other departments.

## **2.5. Work Culture**

Work culture emphasises:

- Continuous learning and training
- Degree of transparency and clarity is very high
- Freedom to experiment
- Quality of work

- Customer loyalty
- Employee engagement

## **2.6. Vision**

To be the leader in the market of Metallic Constructions continuously competing with the aim of improving more.

## **2.7. Mission**

To contribute to the innovation, growth and competitiveness of the metal mechanical industry, in parallel with the defence of the legitimate interests of share holders and financiers.

## **3. Department of Preparation**

### **3.1. Modelling with Tekla Structures**

Tekla Structures is building information modeling software that helps us in modeling structures using different kinds of building materials like steel and concrete. Tekla allows the engineers, drafters to structure the design of a building in 3D, access the information of the structure and also to generate 2D drawings. Tekla has a user friendly manual that helps a beginner to learn and use variety of tools in the software. Tekla also have another manual named First steps with Tekla structures, it is an interactive tutorial, where they help the beginner to build a complete structure with step by step information. After completing the basic trainings, I was very confident to build a small project according to proper dimensions and assemble them.

Later, I was thought how to read the details of the drawing and model a structure using those details. After the basic model was structured using the details; I was given with three projects, where I had to design a structure and compare it with the models that were already designed. This training boosted the level of my confidence; the cuts for welds, placement of bolts in proper orientation, to place the beam in angular positions, the attachment of stiffeners etc all these important detailing were thought. So, the structures I modeled could be ready for manufacturing as well.

### **3.2. Training on Tekla Structures**

- i. Before starting any project on Tekla Structures, the details of the drawing are analyzed first. Analysis of the drawing is done by going through the detailing of the structure completely (i.e. analyzing the dimensions, section detailing, type of profile, material used and visualizing the structure in 3D form.
- ii. We open the Tekla Structure software. Then we login into the software by filling up the parameters by selecting the environment, role and configuration and by clicking ok. When Tekla structure starts, Welcome to Tekla Structure dialog box appears.

The dialog box contains some useful links and at the bottom of the links we select an option whether to create a new model or to open an existing model.

- If a new model is selected the parameters has to filled and has to be saved in the directory.
  - If an existing model is selected a dialog box opens to choose the model that we had saved before.
- iii. After choosing an option, Tekla guides us on to a modeling platform. Modeling platform will have an automatically generated grid.
  - iv. Now select file and click on select project properties in the drop down menu. In project properties toolbar, fill in all the fields required.
  - v. According to the details in the drawing sheet the grid is plotted. The grid is the base outline for any structure because the complete structure is modeled on the

grid. The grid can be changed by altering the parameters in X, Y, Z Coordinates and by altering the values in the labels.

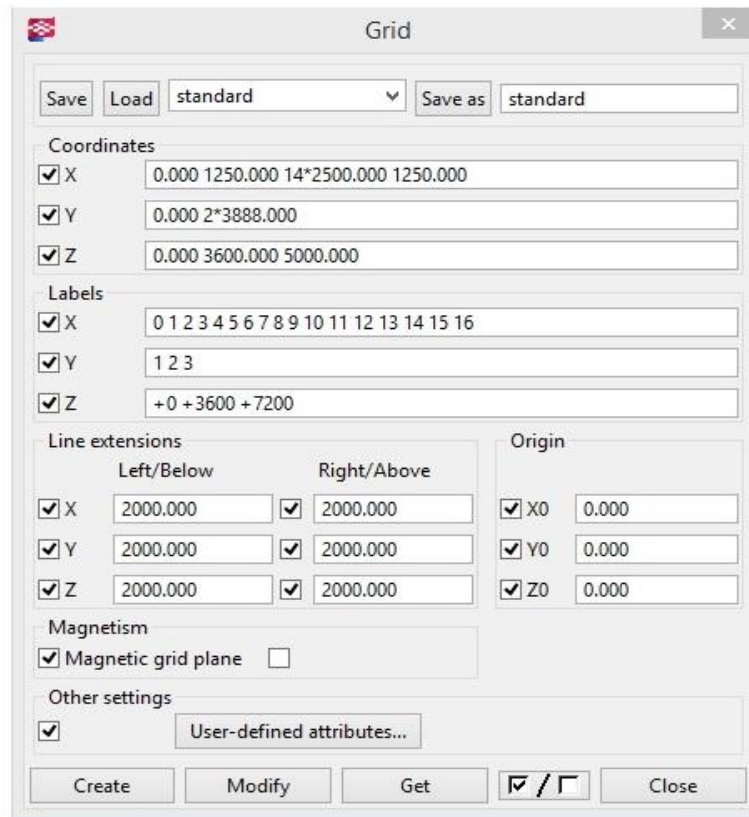

**Figure 2: Grid dialog box** (Structures, Tekla.)

- vi. The beams or columns can be directly plotted according to the draft dimensions or it can be plotted on the reference model that is imported.
- vii. It is also possible to import a reference model from AutoCAD or from other 2D modeling software (Note: The reference model has to be scaled before or after importing into Tekla Structures). It is always better to scale the drawing in a 2D modeling software and save it in a folder.
- viii. Click on create view using two points - choose the view according to the direction of the model to be designed. Another window opens with the direction of the selected view. Select plane parallel to view plane and place the plane on the start point of the model to be designed.
- ix. To import the saved reference model, click on file - select insert reference model - reference model properties dialogue box appears on the screen - in the file name option click on browse and select the saved reference model and change scale 1:1. Click on modify. Place the cursor on the origin of the selected view. The reference model will be placed on the selected view. Now the selected view can be closed.
- x. The reference model can also be adjusted to the required position by selecting the model and right clicking the mouse button and by selecting the move option the reference model can be placed to the required position.
- xi. The beams or columns can be plotted on the reference model for quick modeling of the structure.

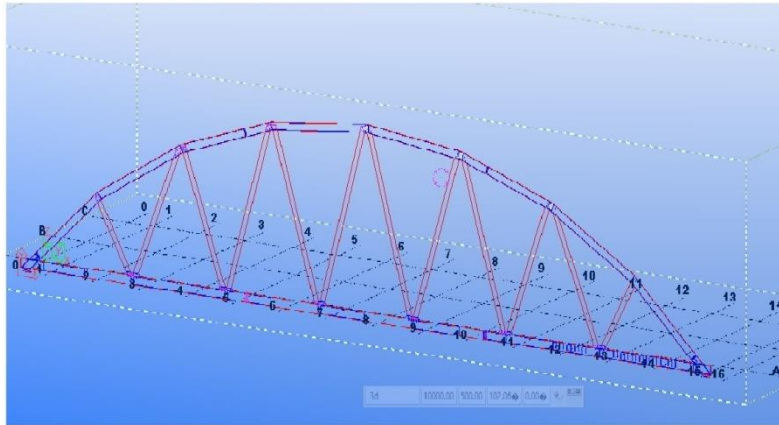

**Figure 3: Reference model imported from 2D software (Structures, Tekla.)**

### 3.3. Experience while working on Tekla Structures:

#### Modeling of Silos and it's structures:

Modeling of Silos with structures is an interactive training with Tekla Structures. This training is very important for a beginner because a beginner will understand how to start a project and end them. In this interactive training, the manual will give an idea about how to alter grids, how the foundations are laid, how the beams and columns can be placed in different angles, formation of roofs, placement of hinges and assembling the projects.

#### Steps for modeling the Silos and it's structures:

- The existing grid has to be modified by double clicking the grid and by completing the grid dialog box as shown below by entering the values in X, Y, Z co-ordinates and labels for the grid lines.
- Click on modify and apply.
- Enter a name in the box next to Save as and click on Save as to save the grid values for later use.

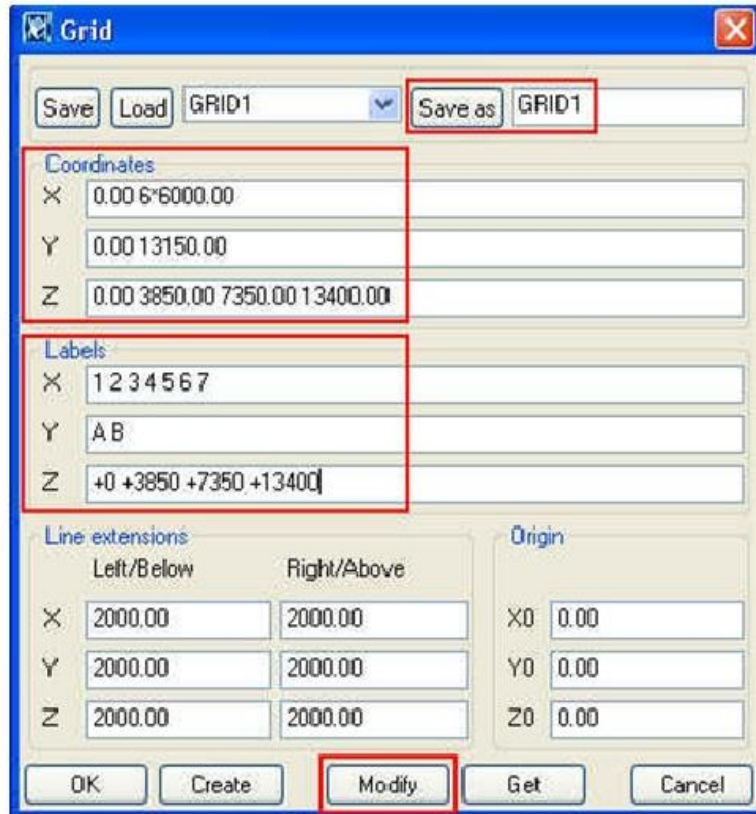

Figure 4: Grid values for modelling silos and its structures (Structures, Tekla.)

- After modifying the grid, foundations are laid as per the general drawing shown below. Foundations for silos are also made according to the general drawing.

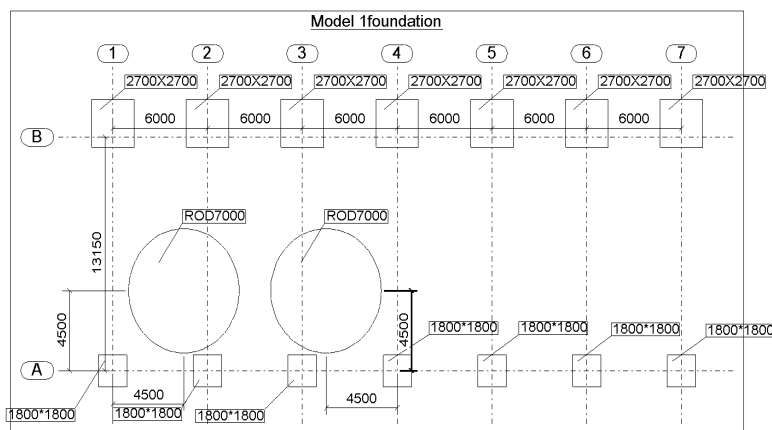
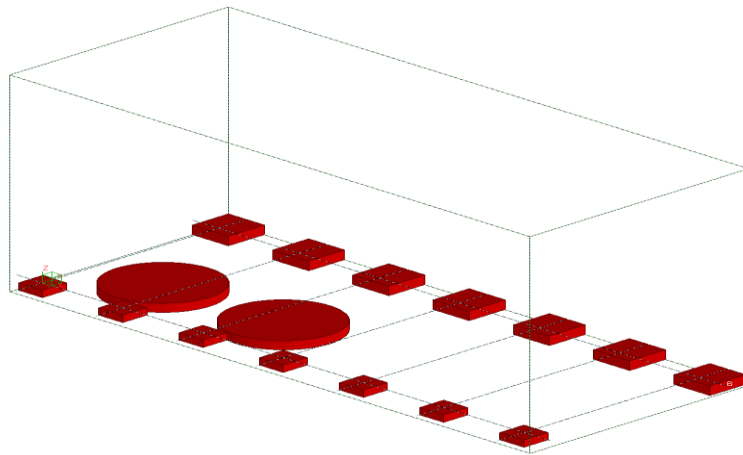

Figure 5: Detailing for pad footings (Structures, Tekla.)

To create the concrete footings, double click on the create pad footing icon, complete the required fields. Click on modify and apply. Place the footings on A1 and B1 (note: The footings have different values).Footings for Silos is made by changing the profile to circular. To translate the footings on the grid, select the footings - right click - copy special - select linear - enter the distance in X - enter the number of copies. Before copying, it is important to check whether the work plane is on the origin.

Now, the footings will look like those shown below:



**Figure 6: Footings for silos and columns (Structures, Tekla.)**

- Steel columns and Concrete Silos are laid on the concrete footings. Like the previous step, we first lay first two columns and copy linear to create other columns. To create columns, Double click on create column- Column properties dialog box opens - complete the table - click modify and apply. To create Silos double click on concrete column - select circular profile and enter the diameter - Select the centre of the silo footings - the silos will be created.

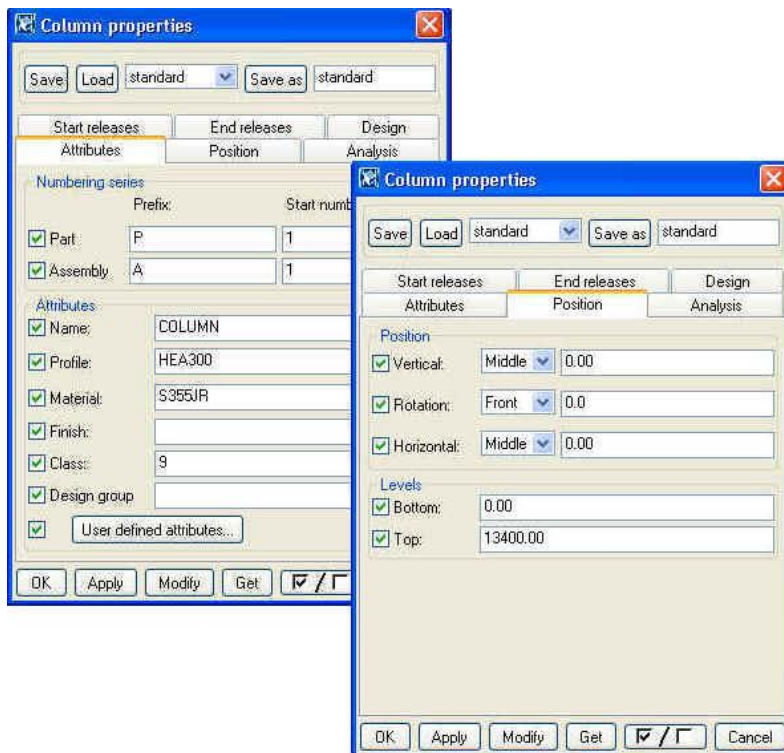

**Figure 7: Column properties dialog box (Structures, Tekla.)**

Pick the intersection of grid A-1 to create one column and pick the grid B-1 to create the second column. Select the columns and copy on to other footings as explained before. Now the Silos and columns will look like those shown below.

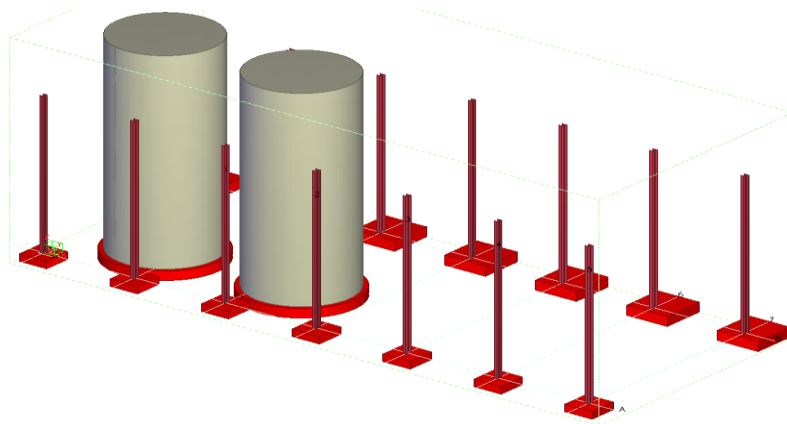

**Figure 8: Silos and its structures** (Structures, Tekla.)

The beams are placed according to the general drawing. To create beams- double click on create beam icon - beam properties dialog box opens - complete the table - click modify and apply. Select the columns accordingly where the beams are to be placed. The structures of beams are created. The height can be adjusted by moving the beam. The beams will look like those shown below.

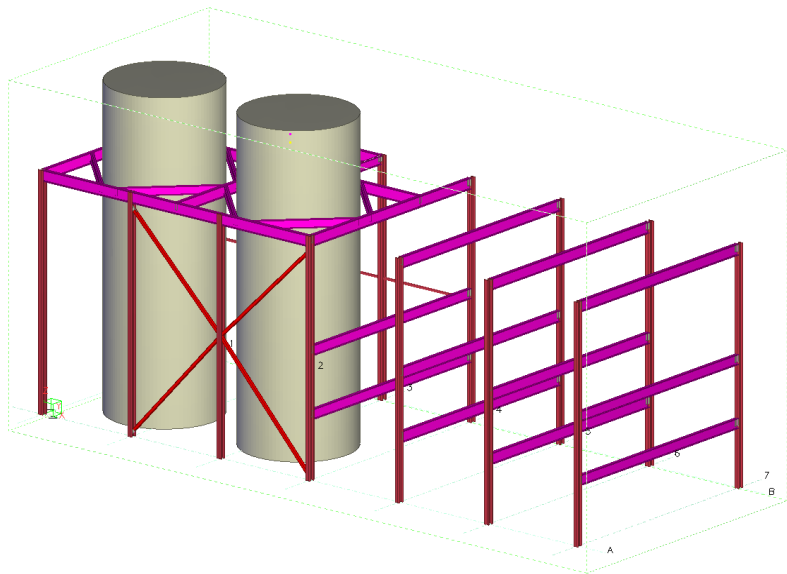

**Figure 9: Placement of beams over the silos** (Structures, Tekla.)

Concrete core hollow slabs are created on the beams. To create slabs - double click on create concrete slab icon - Concrete slab properties dialog box opens - complete the fields - click modify and apply - select four closed points on the beams - Slabs are created. Click on slab and right click to copy - select a corner point and place on the required place. Concrete slabs are created.

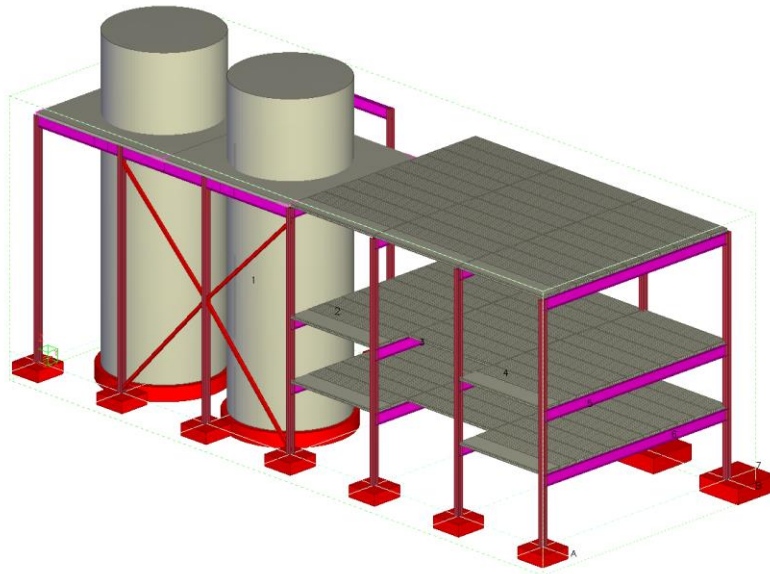

**Figure 10: Construction of slabs on the beams (Structures, Tekla.)**

- Similarly another structure is created with columns, beams and concrete slabs as shown below and is assembled to the above structure.

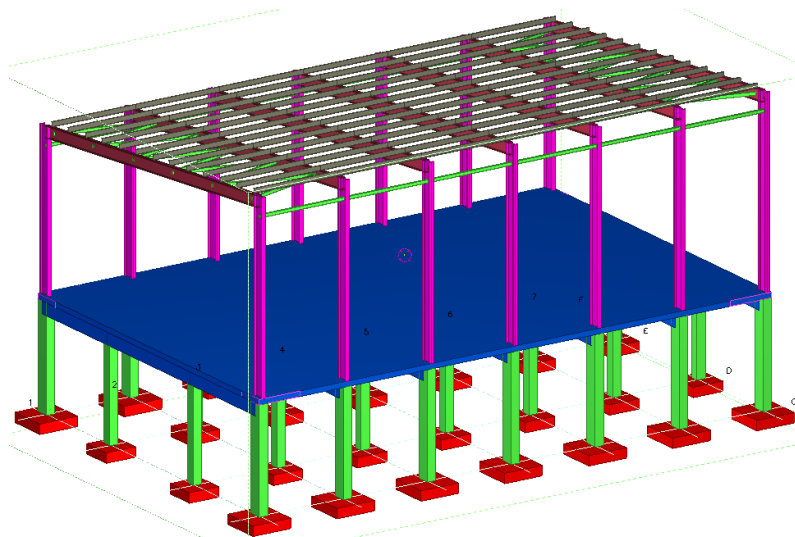

**Figure 11: Structure modelled to assemble with the structure of silos (Structures, Tekla.)**

To assemble the structures, click on tools - select phase manager - select phase 1 - click objects by phases. All the parts in the model get highlighted, indicating they belong to phase1. Now change the phase name to Model1.

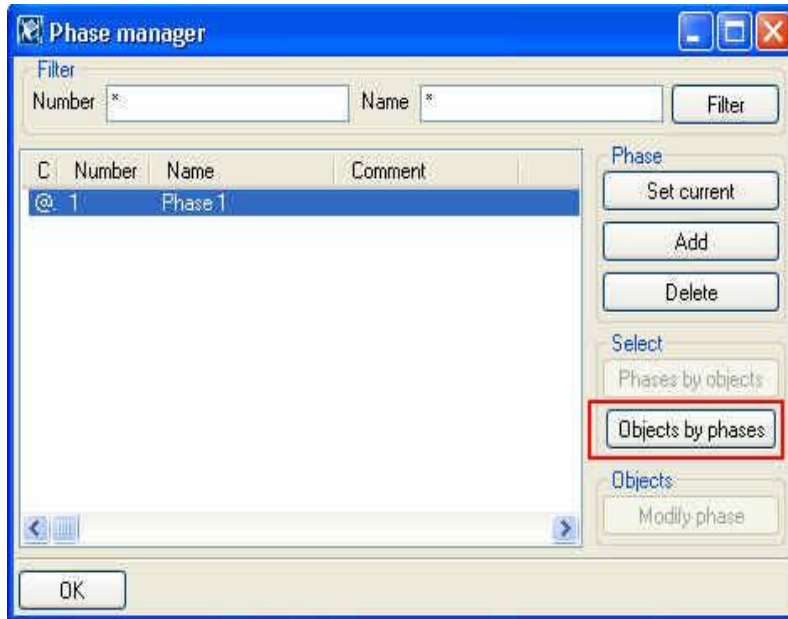

**Figure 12: Change Phase1 to Model1 (Structures, Tekla.)**

Now click Edit - copy special - open from new model - select the second saved structure - enter 1 in the phase number from which to copy the objects - click copy - the model1 parts will now be a combined model.

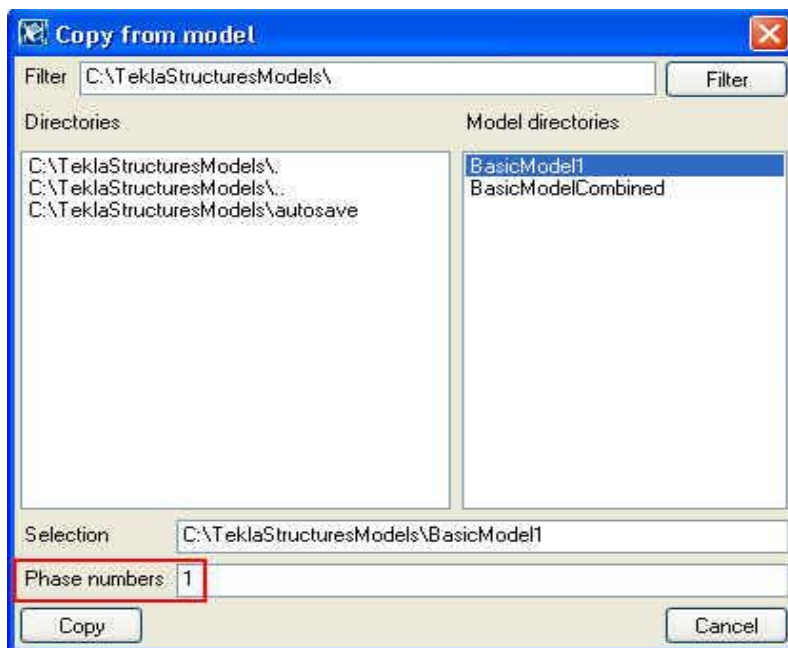

**Figure 13: Assembly selection dialog box (Structures, Tekla.)**

Now the combined model looks as shown.

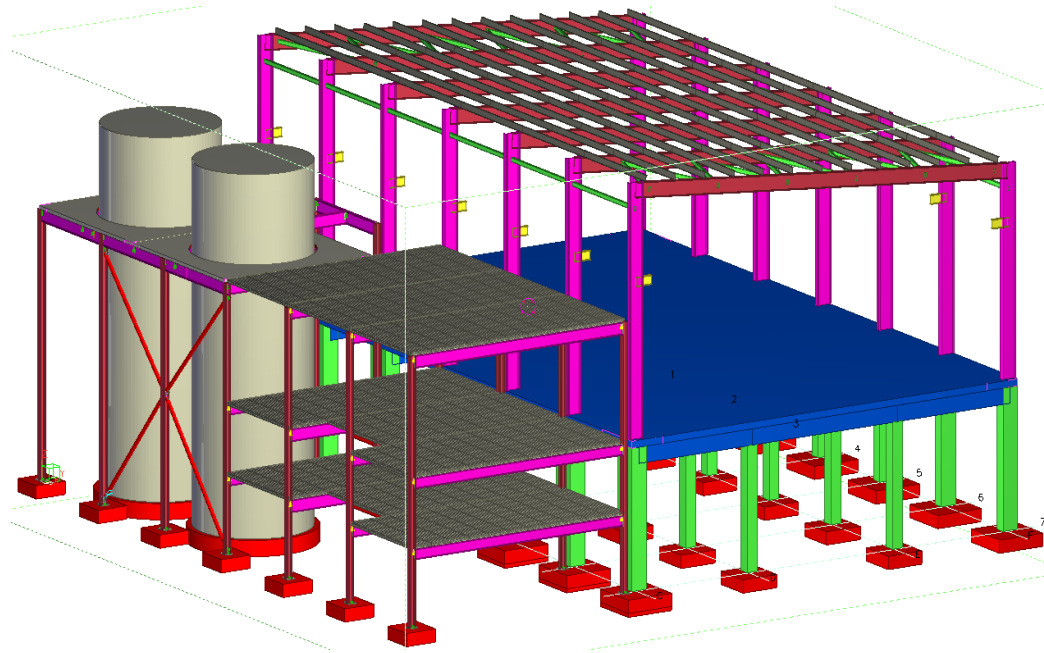

Figure 14: The completed model of silos and its structures (Structures, Tekla.)

### 3.4. Placement of bolts

The basic model training was completed by interacting with Tekla basic model training tutorial. After the completion of the model training, it was time to enter into projects. I was asked to complete some projects during the phase of my training in design. Before starting the projects an additional training was given to place the bolts in proper orientations and to detail the bolt parts.

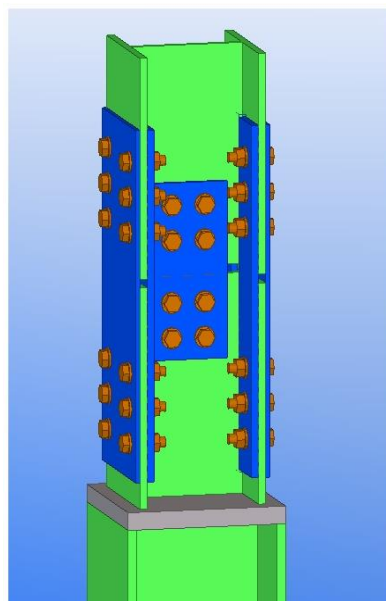

Figure 15: Exercise for placement of bolts (Structures, Tekla.)

Steps to place the bolts:

- i. Double click the create bolts option. Fill in the required details. Select the bolt size, bolt standard etc. In the bolt group the shape can be selected whether the bolt has to be placed in array or circle or XY list and the distance of bolts can be adjusted by altering the values in Bolt distance X and Y. The position of the bolts can also be altered by altering different position tabs on plane or rotation or at depth. The washers, nuts, slotted holes can be selected by highlighting the empty boxes of the diagram present in the Bolt properties dialog box. Click on modify and apply.
- ii. Now select the plate that has to be bolted and click on the middle mouse to set the orientation of the placement of the bolts and select the start and the end points. The bolts will be placed on the part depending on the orientation of selection.
- iii. It is a very important to give detailing to the bolt. Select the Detailing option on the upper task bar - select bolts - edit bolted parts - select the bolts and click on the parts where the bolt has to enter and click on the middle mouse button. The bolts will be placed on the parts exactly.

### **3.5. Working on Project 1(Steel Container):**

My first project on Tekla was to construct a Steel Container. General drawing was given with detailing to construct the project. I had to construct a steel container on Tekla Structures for manufacturing purpose based on the details in the general drawing. In the beginning, it was important for me to understand the drawing as per the details in the drawing sheet. It was also very important to give cuts for the welds.

Steps followed to construct the Steel Container:

- A new model was created and saved the file into a folder. A new model opens with an in-built grid.
- The grid was modified by entering the values in the co-ordinates and labels as shown below.

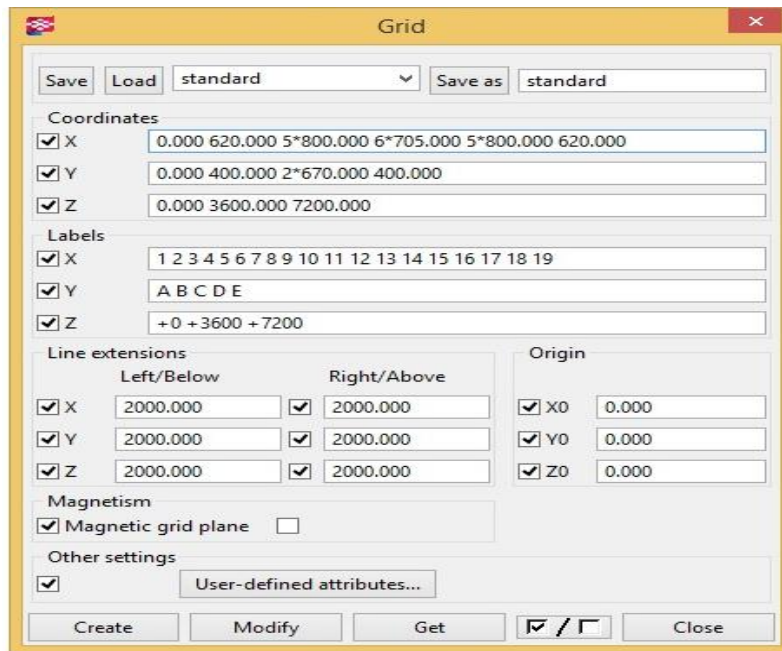

Figure 16: Grid Values to model a Steel container (Structures, Tekla.)

- The grid will look like those in the diagram below.



Figure 17: Top view of grid for Steel container (Structures, Tekla.)

- HEA200 beam profile is used as the base of the steel container. The selection of the beam profile and material has been explained while sharing the information in experience while working on Tekla Structures. The stiffeners are placed at the edges of the beams on either side. To select stiffeners click on component catalog - select stiffeners on the store - the stiffener parameters can be changed by double clicking the selected stiffener - place it on the required position, the stiffener will automatically place on the selected part. The red color part in the below diagram represent the stiffeners.

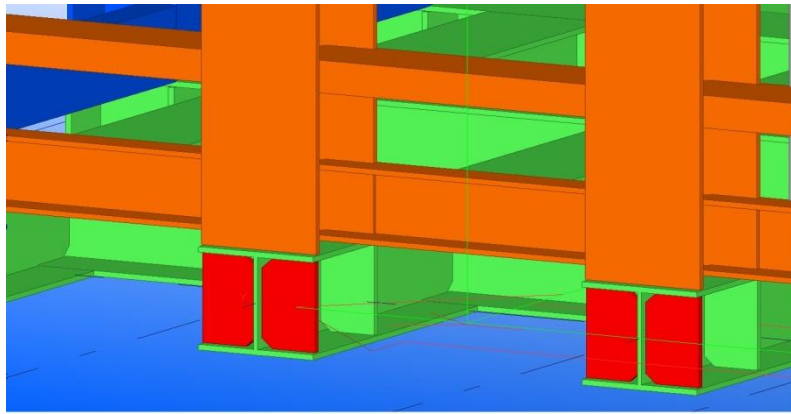

**Figure 18: Stiffeners** (Structures, Tekla.)

Similarly, the beams and columns are created as per the general drawing to complete the Steel Container. One side of the grid is created perfectly and is copy translated according to the dimensions.

- The cuts for welds are given according to the profile of the part selected, a small structural catalog will have the complete information about the type of profiles, and based on the radius of the material the cuts for welds are given.

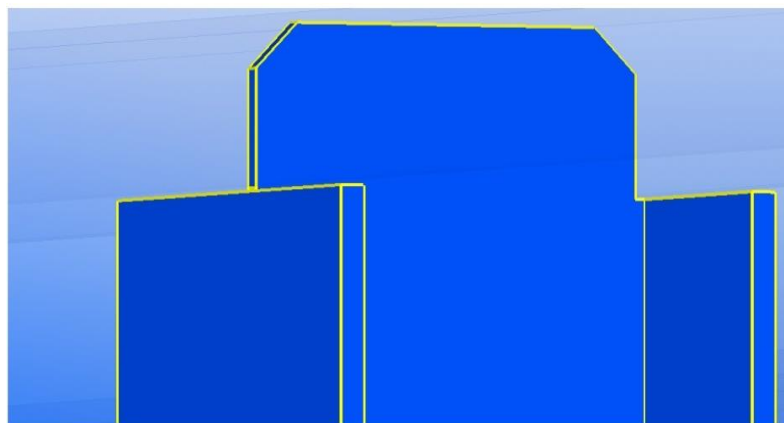

**Figure 19: Cuts for welds** (Structures, Tekla.)

The parts are weld at the required places. Verification of welds is done by holding the ctrl+alt button and selecting the part.

- Now, the complete structure is modeled and will look like in the diagram below.

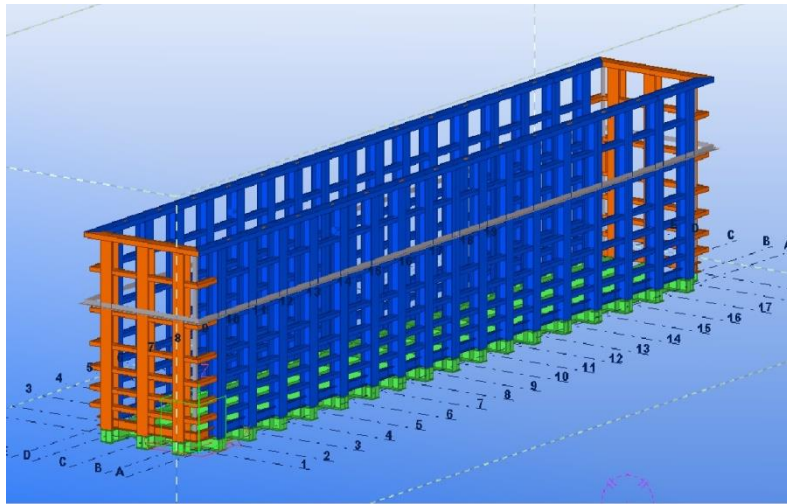

**Figure 20: Completed model of Steel container** (Structures, Tekla.)

### 3.6 Working on Project 2 (Bridge)

Bridge project was a challenging task because there were many detailing and had to carefully cut the beams in particular angles, cuts for welds were to be given, placement of bolts and the application of reinforcement was also important. The bridge project was an important task because many other important tools which I was not familiarized in the previous concepts. For example: i. the use of Macros to view any surface was a very important tool, this tool made it very convenient for me to create a view for any surface on the bridge; ii. To measure the distance of bolts (there is a special tool to measure the bolt spacing's); iii. Use of filters; iv. Creating report.

Steps followed while constructing the bridge:

- The basic step to construct any structure on Tekla is the modification of the grid according to the detailing on the general drawing. The grid was modified by altering the values and co-ordinates as shown below.

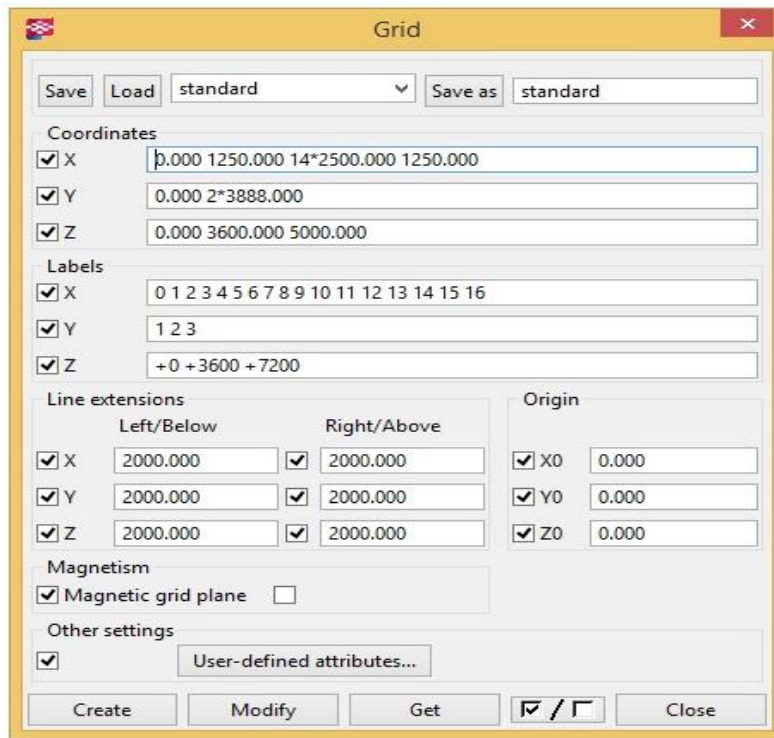

**Figure 21: Grid values for Bridge (Structures, Tekla.)**

The construction of the bridge started by importing a scaled 2D AutoCAD drawing into Tekla structures. The steps for importing the saved 2D models into Tekla structures have been explained previously.

- HEB300 profile type of beam was used as the base of the bridge. But there was a small problem, the beam was supposed to be made tapered. If the beam has to be cut to make tapered then there will be loss of material, instead a plate profile was selected with the profile as mentioned in the general drawing and the plate was converted as a beam to reduce the loss of material. And the connectors were fixed on top of the beam to support the concrete. Connectors are also attached the same way as bolts but while selecting the bolt standard Connector has to be selected.

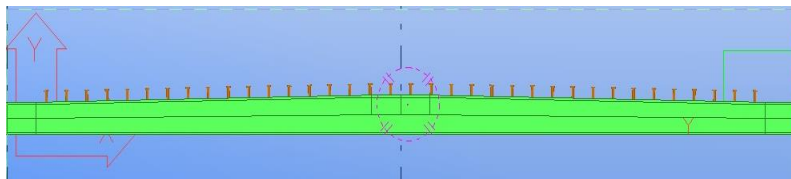

**Figure 22: Base of the Bridge Structure (Structures, Tekla.)**

This tapered plate was cut, welded and attached perfectly, since it is a base and it takes the whole weight of the bridge, it has to be perfectly strong. Later, the base was copied and translated according to the distance mentioned in the general drawing.

- Shoulders to support the pedestrian passage were bolted to the base of the beam. HEA100 profile was used to construct the shoulder. The shoulders were constructed by cutting the beam angularly and welding at their corners and bolting the complete structure to the base of the beam.

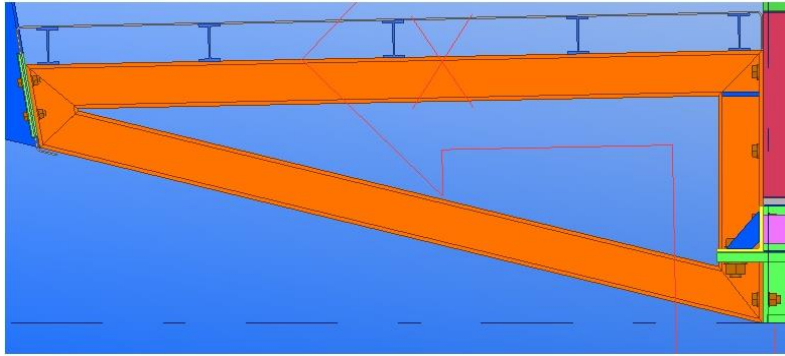

**Figure 23: Shoulders for supporting pedestrian's passage** (Structures, Tekla.)

- Barriers are attached to the shoulder of the bridge. Profile IPE100 was used to create the barrier beams and barrier beams were attached to the shoulder of the beam.

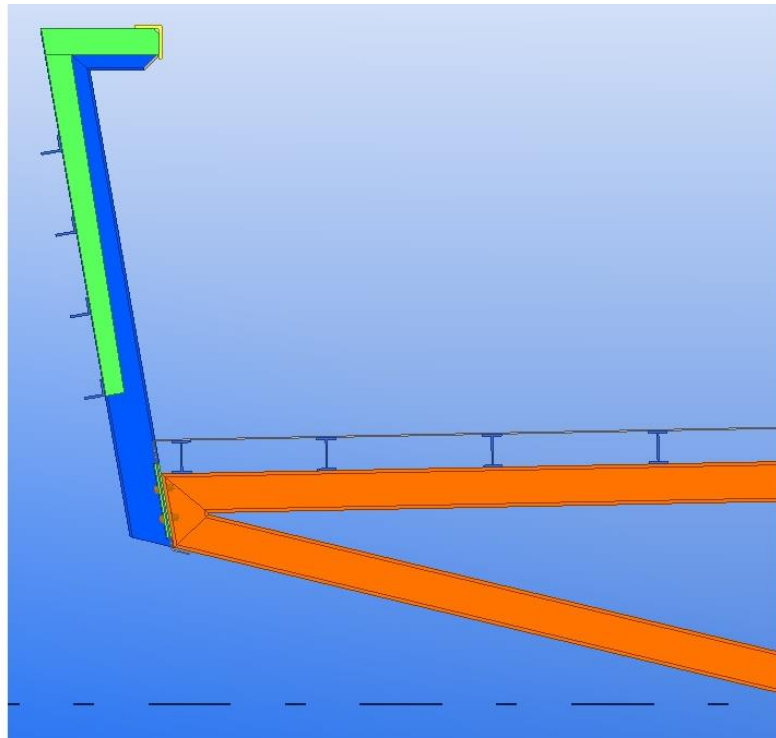

**Figure 24: Barriers attached to the shoulder** (Structures, Tekla.)

- The arch was constructed using three U-profile type beams. The arch is supported by a series of beams placed at a particular angle to support the arch on the top and is bolted to the base of the beam.

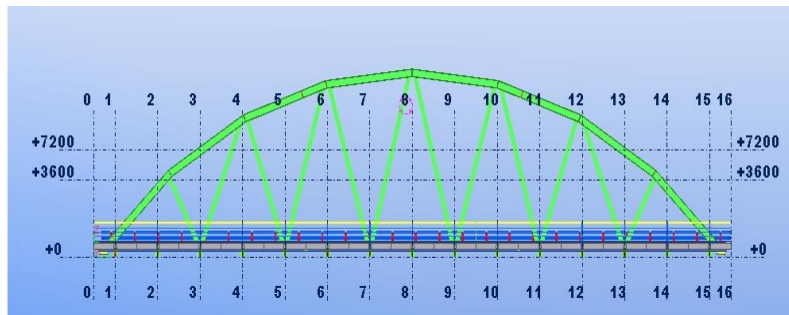

Figure 25: Side view of the arch for bridge (Structures, Tekla.)

- Plates are placed in-between the beams of the arch with proper cuts for welds depending upon the profile of the material. A view of the plate placed in between the beams is shown in the figure below. The red colored material is the plate placed between three beams of the arch.

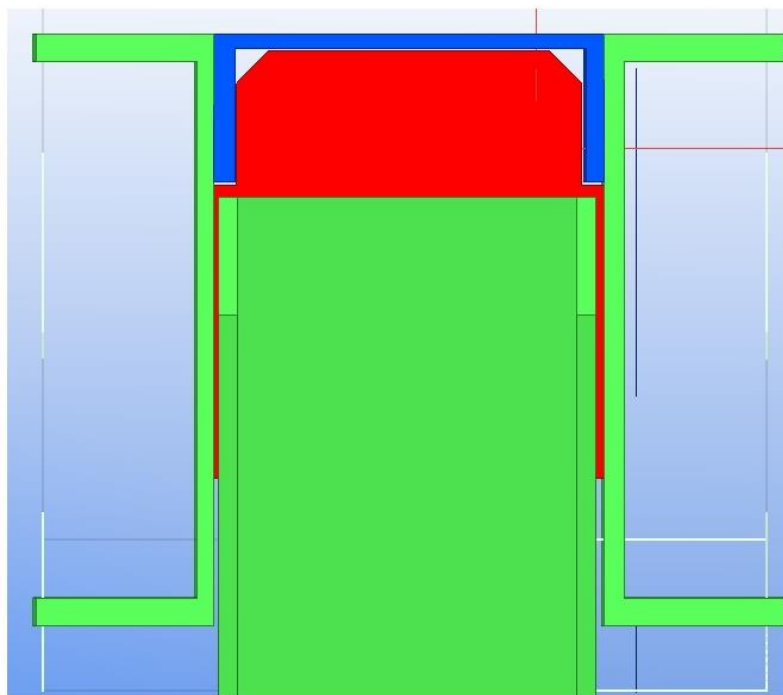

Figure 26: The surface view of the arch (Structures, Tekla.)

- Parapet railings were formed on the edge of the beam base for safety purpose.
- Now, the complete model of the bridge is ready for the manufacturing purpose.
- The diagram below shows the structure of the bridge.

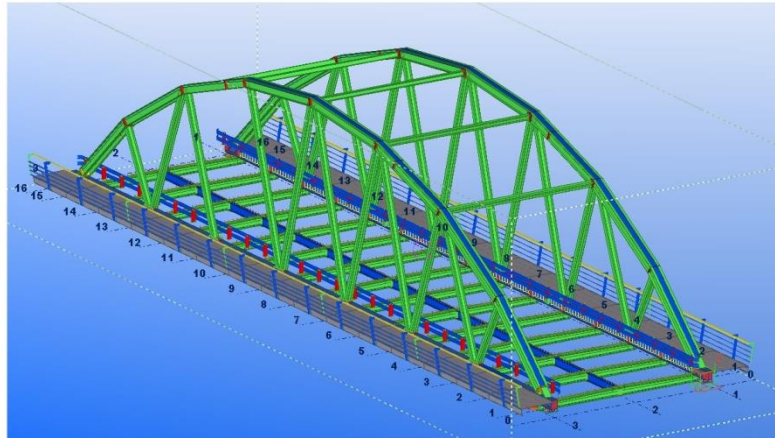

Figure 27: Completed model of the bridge (Structures, Tekla.)

### 3.7. Drawing:

Drawing is the next step where we convert the designed model into a drawing list which contains the complete information of the design that is required for manufacturing. Based on the results of drawing, the part is manufactured. To convert the design to drawing the following steps were followed:

- i. The parts that belong to one system are grouped by assigning the same keywords to prefixes either for parts or assemblies. To assign the same keywords double-click on the part and in the numbering series column change the name of the prefixes of the parts or assemblies to the same keyword that belong to the same system.

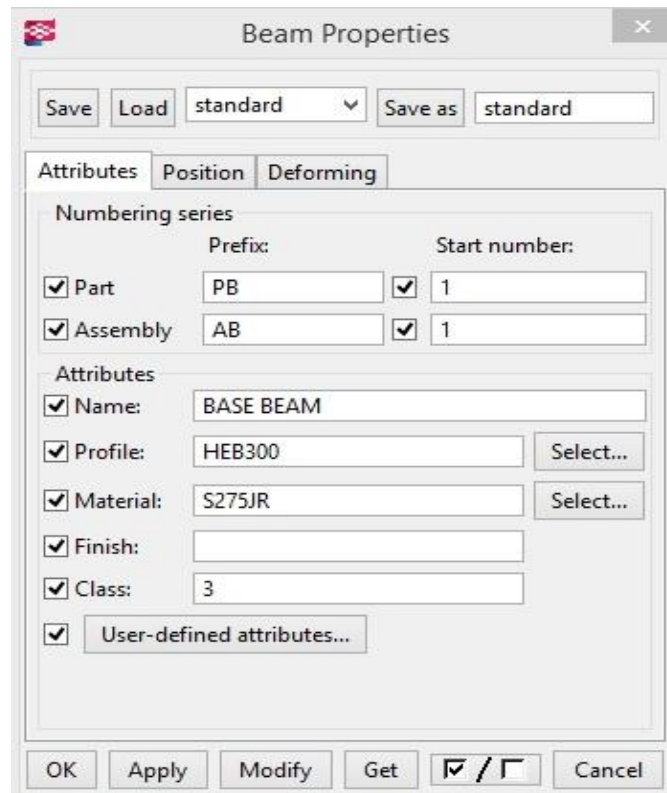

Figure 28: Beam properties dialog box to name prefixes (Structures, Tekla.)

Now go to drawings and reports - select numbering - select number series of selected objects.

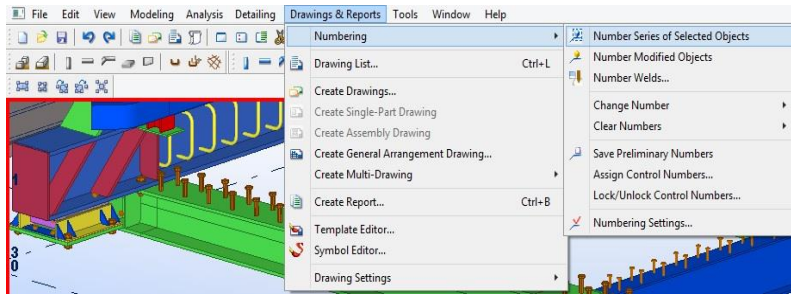

Figure 29: Numbering of the parts (Structures, Tekla.)

- ii. Again click on Drawings & Reports - select create single part drawing and after single part drawing loads click on create assembly drawing.
- iii. Now click on drawing list and there would be a list of parts of the drawing set and it is also possible to view the drawing and modify the changes by clicking twice on any of the detail in the drawing list.
- iv. The drawing that is required for manufacturing will be as shown below. Below drawing is an example of one of the part, there will be many drawings created and each has to be modified as required

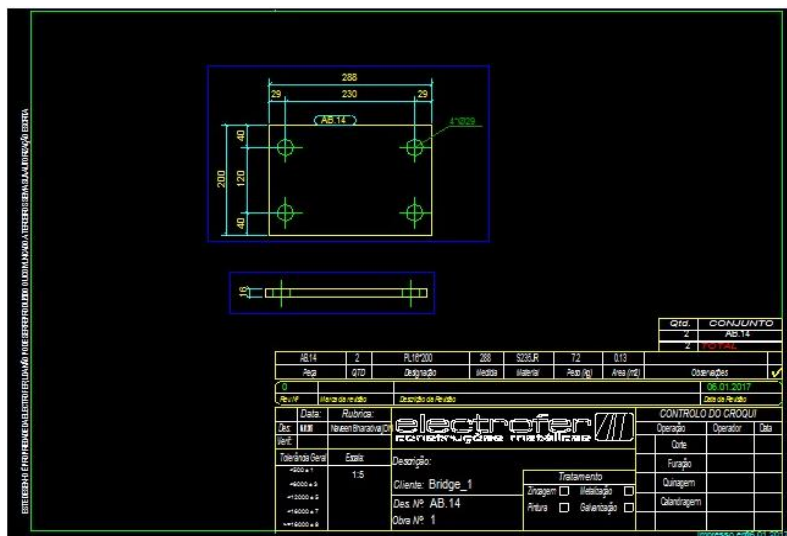

Figure 30: Parts converted to 2D drawing for manufacturing (Structures, Tekla.)

## **4. Department of Quality**

### **4.1. Quality Testing**

Quality testing is a way of preventing mistakes or defects in manufactured products and also ensuring that the products meet certain standards of quality. In quality testing, quality assurance and quality control plays a very important role, in fact these terms are often used interchangeably to ensure the quality of a product or service. However, these two terms have different meanings.

- i. **Quality Assurance (QA):** It is a planned and systematic activity in a quality system to ensure the product is manufactured or serviced according to the standards of quality.
- ii. **Quality Control (QC):** It is a process to fulfil the requirements of a quality by observation technique and systematic activity.

### **4.2. Role of quality assurance manager:**

Quality assurance managers works with other employees in a company to establish procedures and quality standards to fulfil the objectives of the targets by ensuring that the organization goals, efficiency and profitability are accomplished. Below are some of the roles that the quality assurance manager follows:

- **Process:** Quality assurance manager follows certain policies and documents essential to quality assurance. Quality assurance managers prepare a set of documents to organize the plans to assign a representative for a particular job and update quality documentation based on the process on a recognised standard.
- **Team:** Quality assurance managers supervise a team of inspectors (who carry out the detailed assessment of the production) to check whether the products or services are monitored according to the standards. Managers also recruit and train supervisors and provide them with quality guidelines to assign their day to day work.
- **Training:** The quality assurance managers have to provide information for the employees working in the production department about the quality requirements. Quality assurance managers have to provide the training in best practices. They should aim that the production employees are responsible of their duties and are working according to the quality standards.
- **Suppliers:** Quality assurance managers have to work with the suppliers to help formulate the quality of good required. QAM should make note of all the details of the components and materials are according to the quality standards of the manufacturer.
- **Improvement:** Quality assurance managers have to completely participate in quality improvement programs to monitor continuous improvement, aiming to reduce the number of defects and improve the levels of quality of the product to be produced.

### 4.3. Inspection and Test Plan

An inspection and test plan is a document comprising of systematic detail to test a system or a component such as visual inspection, welding inspection, dimensional inspection, factory acceptance test etc. The standards of European such as CEN, CENELEC or American standards such as ANSI/AWS D1.1/D1.5 (Society, 1999) are applied for inspection and test plan in steel structure manufacturing shop. For, ITP the witness of some inspection and third party witness are mandatory and it cannot be changed (inspection-for-industry.com , 2012-2013) . There are some points that are to be checked, reviewed and clarified by the third party inspector; some of the points that are to be witnessed are as follows:

- Raw material inspection, material certification document.
- Welding inspection by witnessing welding addition material certification, manufacturer certificate.
- Dimensional control of components – verification from the fabrication drawing, cut drawing and assembly drawing, by following general dimensional tolerances.
- Surface treatment – reference documents, verifying as per the specific project document.
- Painting – Inspection by testing wet and dry thickness, verifying by technical paint documentation.
- To check whether NDT procedures are properly applied.

Below is an example of ITP document for steel structure:

Inspection and Test Plan for Steel Structure								
No.	Inspection and Test Plan	Reference Document	Acceptance Criteria	Verifying Document	Activity By			Remark
					Manuf.	TPI	Client	
1	Pre-Inspection Meeting	Spec.	Spec.	MOM	H	H	H	-
<b>Before Manufacturing</b>								
2	DWG, Design, Calculation Document	AISC	AISC	DWG, Calculation book	H	R	A	-
3	WPS&PQR	AWS D1.1	AWS D1.1	Welding Book	H	R	A	-
4	Welder Qualification Certificates	AWS D1.1	AWS D1.1	Certificates	H	R	-	-
5	NDT procedures	AWS D1.1	AWS D1.1	Procedures	H	R	A	-
6	NDE Personnel Certificates	AWS D1.1	AWS D1.1	Certificates	H	R	-	-
7	Painting Procedure	SSPC	SSPC	Procedure	H	R	A	-
<b>Materials</b>								
8	Visual Inspection of Materials for General Appearance, Corrosion and Dimension	ASTM	ASTM	Original Material Certificates	H	H	-	-
9	Welding Material Control	ASME II/AWS	ASMEII/AWS	Report	H	W	-	-
10	Review of Certificates	ASTM	ASTM	Certificates	H	H	-	-

Figure 31: ITP reference document for steel structures (www.inspection-for-industry.com)

11	Inspection of Bolt , Nut and Washers (General Appearance, Corrosion and Dimension, Chemical Composition and Mechanical Properties)	ASTM	ASTM	Report	H	W	-	
12	Material Identification	ASTM	ASTM	Report	H	H	-	
<b>During Fabrication</b>								
13	Fit-Up Inspection	AWS D1.1	AWS D1.1	Report	H	SW	-	
14	Dimensional and Visual Inspection for Correct Location, Orientation, straightness and Dimension	DWG	DWG	Report	H	W	-	
15	Visual Inspection of Welds for Weldment Quality/Defects, Weld Appearance and etc.	AWS D1.1	AWS D1.1	Report	H	W	-	
16	NDE Examination	Procedure	Procedure	Report	H	SW	-	
<b>Final Inspection</b>								
17	Final Visual & Dimensional Check	DWG	DWG	Report	H	H	-	-
18	Surface Preparation and Painting	Procedure	Procedure	Report	H	W	-	-
19	Check of Final Book	Spec.	Spec.	DWG/ P.O	H	R	-	
<b>Documentation</b>								

**Figure 32: ITP reference document for steel structures** (www.inspection- for- industry.com)

20	Inspection Reports	Spec./DWG	Spec./DWG	Report	H	R	-	-
21	NCR	Spec./DWG	Spec./DWG	Report	H	R	-	-
22	Review Final Data Report	Spec./DWG	Spec./DWG	Report	H	R	-	-
<b>Pre-Shipment Inspection</b>								
23	Preservation and Packing	Spec.	Spec.	Report	H	H	-	-
24	Marking	Spec.	Spec.	Report	H	H	-	-
25	Loading Inspection	Spec.	Spec.	Report	H	H	-	-
26	Shipping Document Control	Procedure	Spec.	Packing List	H	H	-	-

Abbreviations:

H: Hold Point = Hold on the production till TPI Inspector performs inspection and supervise the required test

W: Witness Point = Manufacture shall notify client and TPI Inspector but there is no hold on the production; Client can waive this inspection based on his discretion and informs TPI Inspector accordingly.

R: Document Review = Review means Review document, which includes of material test certificates, WPS, PQR, NDT Procedures and etc.

A: Approval

SW: Spot Witness = for items with spot witness manufacture shall notify TPI inspector as fulfilling the monitoring; For example one random visit for whole UT tests or one or two visits for whole surface preparation works for painting.

MOM: Minute of Meeting

P.O: Purchase Order

**Figure 33: ITP reference document for steel structures** (www.inspection- for- industry.com)

In the department of quality I was asked to learn about the European standards so it would be helpful for me to specify the requirements for execution of structural steel

work as structures or as manufactured components, produced from different manufacturing techniques.

The European standards documents give us the complete information about how the steel structures are to be manufactured, their execution, delivery and identification, cutting of steel structures, dimensioning of holes, requirements for welding plan, erection methods, inspection, testing and correction etc for the countries that are bound to implement European Standards.

The Execution classes are selected according to the hazards connected with the use of the structure. The selection of the execution classes will be from the suggested criteria for different categories. The categories are explained below.

- i. Suggested criteria for Service Categories – The service categories are divided as SC1 and SC2. SC1 category signifies the structures and components designed for quasi static actions only (example: buildings). SC2 category signifies the structures designed for fatigue actions (examples: roads, railway bridges, structures that are susceptible to vibrations induced by wind, crowd or rotating machinery) (Execution of steel structures and aluminum structures - Part 2: Technical requirements for steel structures, August 2011).
- ii. Suggested criteria for Production Categories – The production categories are divided as PC1 and PC2. PC1 category signifies the non welded components manufactured from any steel grade products, welded components manufactured from low steel grade products. PC2 at ITP reference document for steel structures categories signifies the welded components manufactured from high graded steels, components that are assembled by welding on construction site, components with hot forming manufacturing(Execution of steel structures and aluminum structures - Part 2: Technical requirements for steel structures, August 2011).
- iii. Consequence classes are divided as CC1, CC2 and CC3 depending upon the safety of the humans in the working environment. CC1 is referred to as less in loss of human life, Economic, social or environmental consequences are less importance or negligible. CC2 is termed as average loss of human life, Economic, social or environmental consequences are given medium importance. CC3 is termed as high in loss of human life, Economic, social or environmental consequences are given maximum importance (Execution of steel structures and aluminum structures - Part 2: Technical requirements for steel structures, August 2011).

Considering all these categories the execution classes are selected by selecting the nature of service, production and consequences of human lives in the working environment. Figure 4 is the recommended matrix for determination of execution classes.

Execution class 4 is applied to special structures or the structures with extreme consequences for structural failure as required by National provisions.

Consequences classes		CC1		CC2		CC2	
Service category		SC1	SC2	SC1	SC2	SC1	SC2
Production categories	PC1	EXC1	EXC2	EXC2	EXC3	EXC3 <sup>a</sup>	EXC3 <sup>a</sup>
	PC2	EXC2	EXC2	EXC2	EXC3	EXC3 <sup>a</sup>	EXC4

<sup>a</sup> EXC4 should be applied to special structures or structures with extreme consequences of a structural failure as required by national provisions

Figure 34: Recommended matrix for determination of execution classes (Specifying the right execution class)

#### 4.4. Welding Process used in Electrofer:

Electrofer is a metallic construction company, they produce steel structures. To produce steel components welding is a very important activity. The welding process may take place in the factory shop or on the site. Different welding methods are used by this company to fuse the steel surfaces. The process numbers are according to the European standard EN ISO 4063. The welding process used in the factory shop floor is as follows:

1. **MAG 135 welding-** MAG is abbreviated as Metal Active Gas (MAG) welding in European standards and Gas Metal Arc Welding (GMAW) in American welding society (AWS) standards. The principle of Metal Active Gas (MAG) welding is same as Metal Inert Gas (MIG) welding. In MAG, the active gas is Argon which is used as the shielding gas; Argon reacts with the welding bath. But usually Argon is mixed with Carbon-di-oxide (CO<sub>2</sub>) with the ratio 82:18 or with other gases. The addition of CO<sub>2</sub> in this welding process influence the process in the welding arc and the metal transition, better flashing output, better penetration, good weld metal quality (báňské, 2008).

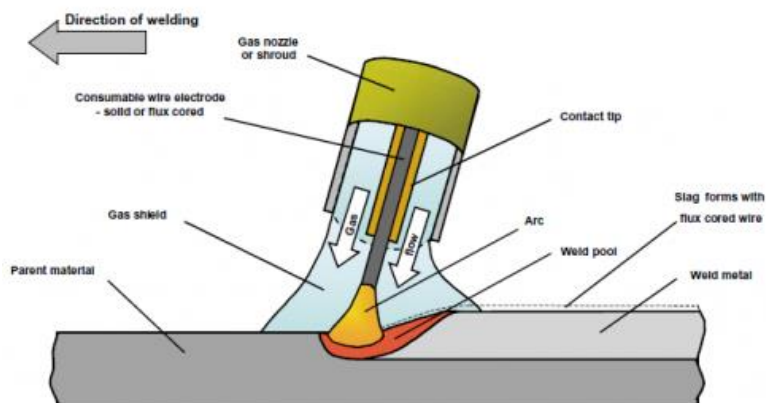

Figure 35: Metal Active Gas welding, process 135 (SteelConstruction.info- The free encyclopedia for UK steel construction information)

2. **FCAW 136 welding-** FCAW is abbreviated as Flux Cored Arc Welding (FCAW). FCAW is a semi-automatic or an automatic welding process, FCAW uses a continuously fed consumable tubular electrode containing flux and a constant voltage (Flux cored Arc welding).

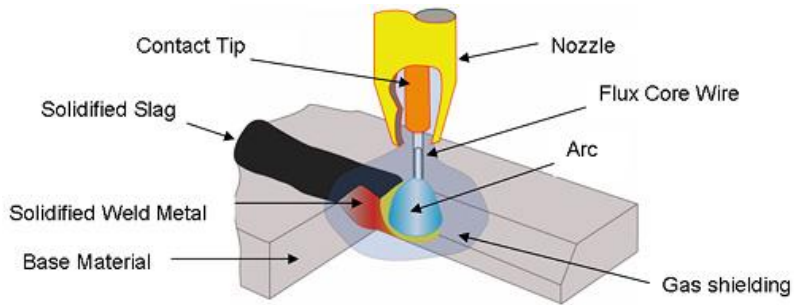

Figure 36: Flux Cored Arc Welding, process 136(Welding technology or techniques, 2016)

3. **SAW 121 welding-** SAW is Submerged Arc Welding is a common arc welding process. SAW process includes formation of arc between a continuously fed electrode and the work piece, this process uses a flux to protect the contamination of the welding from the outer atmosphere.

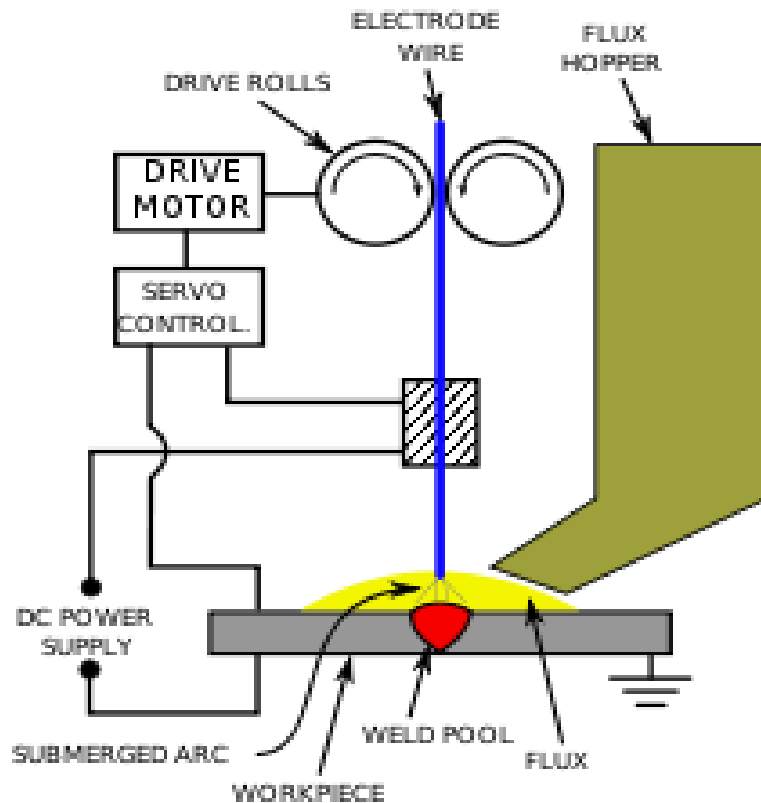

Figure 37: Submerged Arc Welding, process 121(Submerged Arc Welding)

4. **Drawn arc stud welding with ceramic ferrule process 783** - The process "Drawn arc stud welding" is used for studs of an approximate diameter of 3 to 25 mm, welding current up to 3.000 A and welding times up to 3.000 ms(info@koeco.net).

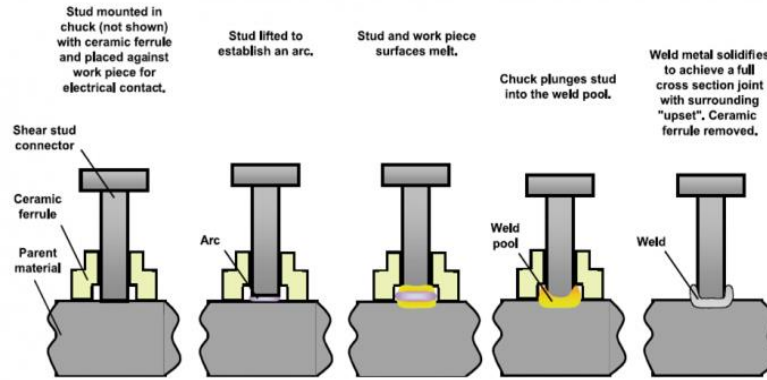

Figure 38: Drawn arc stud welding with ceramic ferrule, process 783(SteelConstruction.info- The free encyclopedia for UK steel construction information)

5. **SMAW 111 welding:** SMAW welding is abbreviated as Shielded Metal Arc Welding. As discussed earlier, welding is done in the factory shop or on the site. The above four welding are done in the factory shop but this type of welding is usually carried on the site. SMAW uses a consumable electrode covered with flux to lay the weld.

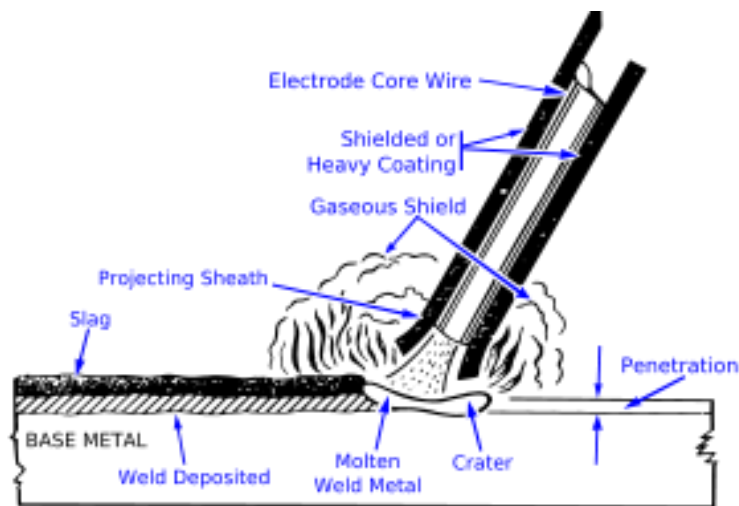

Figure 39: Shielded Metal Arc Welding, process 111(Houldcroft, 1967)

#### 4.5. Welding Positions:

Welding cannot be always done in the required desired position. It must be done in the position in which the part must be used. Often it is done in horizontal or vertical positions depending upon the definition and description given in the drawing. The welding standards may slightly differ in American and European standards. The fillet and groove positions have different welding positions depending upon the position it has to be welded. The fillet weld has different positions and they are defined as:

- i. 1F: Flat position
- ii. 2F: Horizontal position
- iii. 3F: Vertical position
- iv. 4F: Overhead Position

Similarly, groove weld has different positions and the diagram below clearly indicates the position for fillet and groove welds.

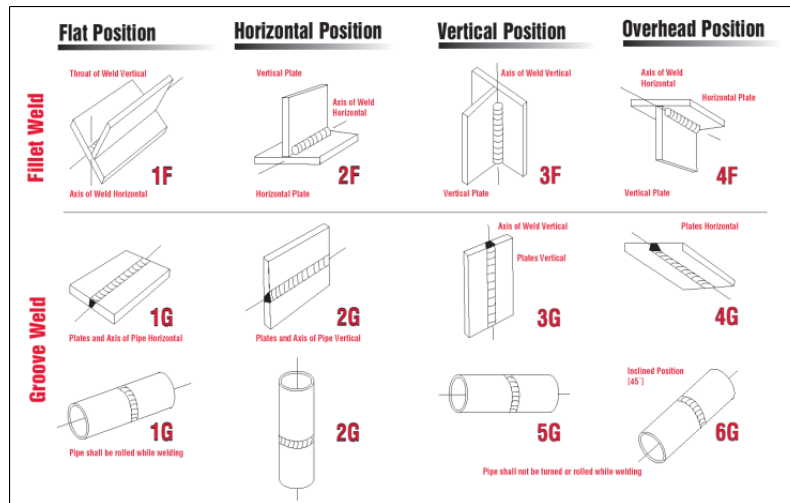

**Figure 40: Various positions that a welding can be made** (welding- Basic steps, terms, application, different welding joint and positions)

#### 4.6. Welding Inspection:

Welding inspection is carried out according to European or AWS standards. According to European standards the inspection can be done by visual inspection, ultrasonic inspection radiographic inspection and dye penetration inspection etc. As in the case of AWS standards the inspection is carried out by visual inspection and radiographic inspection. Ultrasonic inspection is not allowed in AWS standards. Each execution classes will have different visual inspection levels and the welding parameters should not exceed the values. According to AWS standards the welding dimensional qualification is done by examining the leg length values and according to European standards the welding dimensional qualification is done by examining the throat thickness. For each throat thickness levels there will be permissible values as per the execution class levels and the throat values for each dimensions should not exceed the permissible value. The below picture explains permissible values for each throat thickness with respect to their execution class and the chart explains the non recommendation of the welding types.

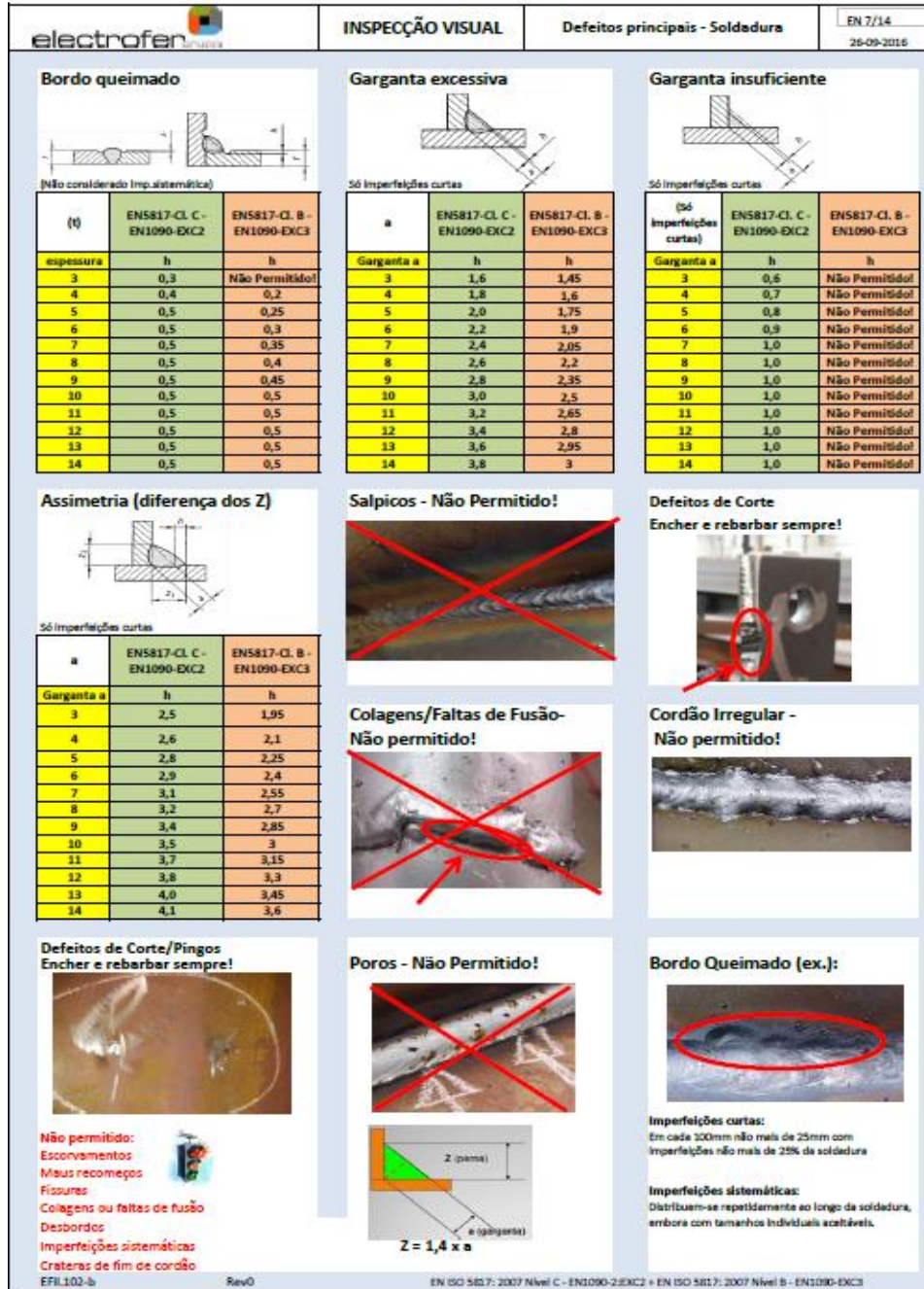

Figure 41: Visual inspection and major welding defects chart (Visual Inspection and Major defects- welding)

To measure the throat thickness and leg length a weld measuring gauge is used. There are different weld measuring gauges for measuring different parameters (i.e. to measure the internal misalignment, root weld space, crown thickness, throat thickness, leg length etc). In this the device to measure throat thickness and leg-length has been shown.

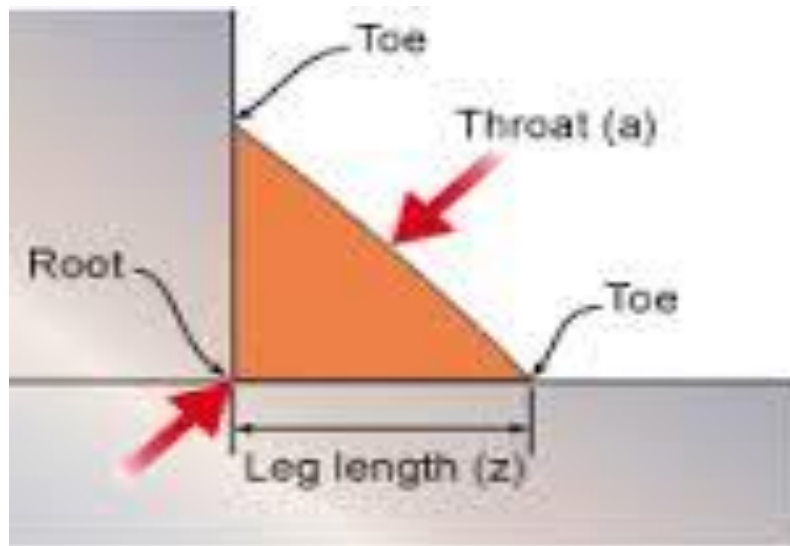

Figure 42: Fillet welding terms (Mathers)



Figure 43: Digital throat weld measuring gauge (Tools Instruments)



Figure 44: Leg-length measuring cam type gauge (Tools Instruments)

Two more welding inspections are done in the production department of my host company other than visual inspection, they are:

- i. Ultrasonic inspection
- ii. Magnetic particle inspection

#### 4.7. Ultrasonic inspection

Ultrasonic inspection is a non-destructive testing technique used to detect flaws in the weld parts by propagating short waves with frequencies ranging from 0.1-15MHz(Ultrasonic testing, 2009).

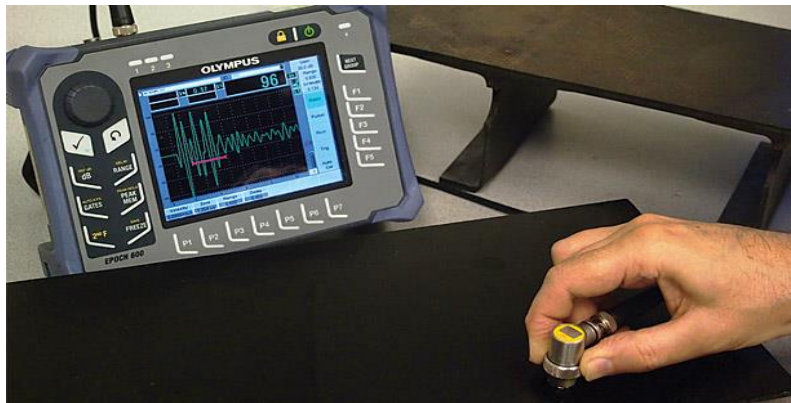

**Figure 45: Ultrasonic test equipment** (St. Johns group of Institution)

As per the explanation given by the welding inspector of my host company, inspection tests will be carried out by the company that takes up the project and a third party inspector according to European Union Standards to test the defects in the weld parts. When the third party inspector signifies that the weld is acceptable then the third party inspector makes the conclusions and writes a report and hands it over to the customer and the company that takes up the project. In Ultrasonic testing usually a couplant is applied (i.e. a couplant is a liquid material that facilitates the transmission of ultrasonic energy from the transducer into the test specimen) on the weld part that is to be inspected and a probe is moved on the applied area, if the probe detects any defect it sends signal to the ultrasonic test equipment and there will be a variation in the graph.

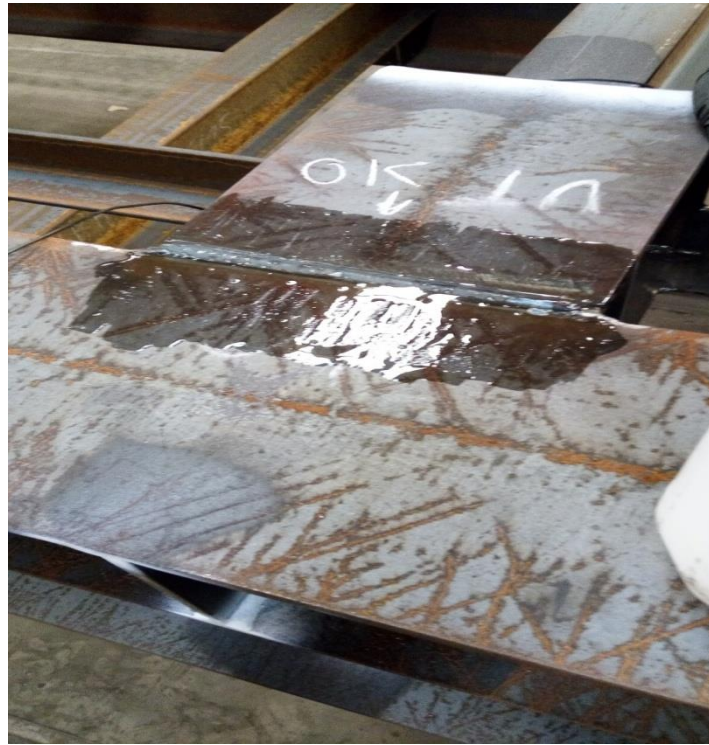

**Figure 46: Couplant applied on the weld part** (Elctrofer Group, 2017)

#### **4.8. Magnetic particle inspection**

Magnetic particle inspection is also a non destructive process to detect defects in the weld parts. This method is accomplished by inducing a magnetic field in a ferromagnetic material and dusting the surface with iron particles(either dry or suspended in liquid) (St. Johns group of Institution), if there is any defect on the weld area then the defect is visible on the surface of the weld area. The information for ITP is carried out according to European standards in the host company.



**Figure 47: Magnetic particle testing** (St. Johns group of Institution)

## 5. Department of Production

### 5.1. Production

Production is the process of transforming tangible inputs (raw materials, semi-finished goods, sub-assemblies etc) and intangible inputs (ideas, information, knowledge) into a finished goods or services. Usually, fabrication is the process that is used to produce steel structure components. The Fabrication of steel structures uses readily available standard steel components which are purchased from the steel makers. Other components such as bolts, preventive coatings, welding electrodes or wires are purchased from other specialist suppliers. But in fabrication of steel structures welding plays a very important role.

Productions engineers plan the schedules of production and make sure the production runs smoothly and deliver the finely finished goods on time to the customer. Production engineers will have many responsibilities since; they are the main players who plan the overall production process in an industry.

Some of the main duties of Production managers are listed below:

- Production managers must have the basic knowledge of engineering processes, since he has to train other workers who will be working in the department of production.
- To improve the production efficiency of the industry by planning production processes and scheduling the duties to the workers accordingly.
- Work with the department of quality to improve the quality of the manufacturing process.
- He has to calculate the workspace requirements and should design production floor strategy to use the work space efficiently.
- The production managers must calculate the production costs, availability of the production resources, calculate the time involved for the production of jobs, estimate the requirements and inform the organization about the resources that are required for the next job.
- Manage the production personnels for the Project and assign them for the Project by providing them proper training on the work.
- Production manager should always be upgraded with the new production techniques in order to improve the maximum production and efficiency, which will in turn increase the profits of the organization.
- Production manager has to make a template to assign the production personnels for the specific job, also must analyze the manufacturing methods, production process and also the production schedule in delivering the Project. The production manager has to make a report of all these details and submit it to the management to clearly identify the future requirements of manufacturing.
- The production methodology and the duties of the production manager might change according to each company, country etc. The points above are some of the general duties of a production manager.

## **5.2. Production procedure:**

### **5.2.1 Design for economic production-**

Any product that has to be produced should be designed first considering the technical factors (such as tolerances, gaps for the weld parts, placement of bolts etc.) that apply to the development of products. The products have to be designed with the conformance of the standards in order to reduce non-conformities. Since, Electrofer group is a metallic construction industry certain criterias are followed for the erection of steel structures. Keeping this in mind the designers has to model the parts. The production managers and project managers have to provide them sufficient information to develop a structural drawing efficiently. Production managers interaction with the designers while developing a new task will be an important factor to be considered because the production manager will estimate the cost of production and the design has to be made accordingly (for example, it is better to ensure that the most commonly used beam sections to be considered for particular application, sometimes when we have a tapered beams it is better to choose plates and make beam sections similar to the specified beam in the drawing. If the designers plan to cut the standard beam then there will be a huge loss of the material which in turn there will be a huge loss in the cost of the production). The design should not be very complex because if the complexity of the design is too high, then the cost of the fabrication will also be very high.

The production manager has to explain the designers to design a structure considering the requirements on the production floor. If the designs are adopted with the conditions that are not matching the requirements on the production floor then there will be unnecessary increase in the cost of production.

The 3D design models will be converted to 2D drawings with complete detailings and will be sent to the department of preparation for cut sections.

### **5.2.2 Cut optimization**

In preparation, the working persons in this department use an optimization software that nests the two dimensional drawings within a large metal sheet, i.e. the software arranges the cut sections of beams or plates in such a way that the drawing uses the maximum space over the metal sheet. So, the wastage of the material is reduced. The figure below is an example of how the cut sections of beams or plates are assembled on a large sheet. The preparation personnel will feed requirements in the software based on the availability of raw materials. The program for cut will be automatically generated by the software depending on the availability of the materials and when the program is fed into the CNC machine, the machine cuts the pieces according to the program generated.

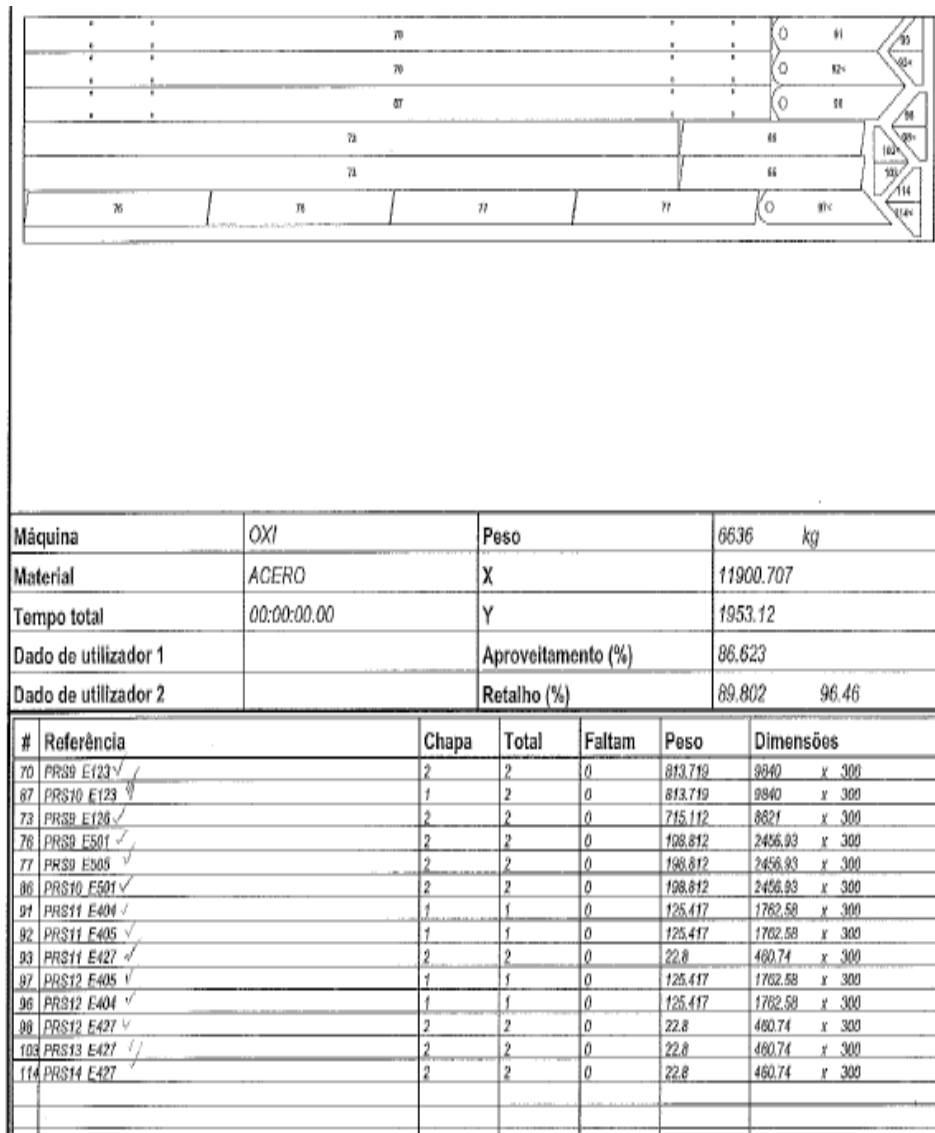

Figure 48: Arrangement of plates for CNC cut (Electrofer Group, 2017)

Most modern steel structure fabrication industries have a CAD/CAM environment, where the computer aided drawing or detailing and computer aided machining is directly linked to this environment. To cut the steel plates or sections a computer controlled numeric plasma machine is used. The department of preparation organizes the plates and sections to be cut over a metal sheet as per the availability of material in the stockyard. A program is generated by the optimization software and will be fed to the CNC plasma machine. Later, the person in-charge of the plasma cut finds the program for cut in the CNC console and sets the X and Y co-ordinates to (0, 0) i.e. considered to be the start point of the plate and the CNC machine stores this co-ordinates as the starting point also the height of the Z co-ordinate is set to ensure that the Z co-ordinate does not cut above or completely below the thickness of the plate.



**Figure 49: Plasma cut** (Elctrofer Group, 2017)

### **5.2.3 Fabrication process:**

Fabrication is a process where the metal structures are built by cutting, bending and assembling. Steel fabrication can be done either in the shop floor or on the site. The fabrication carried out in the shop floor is assured of quality and is bound to have fewer imperfections.

The fabrication process is generally carried out in a systematic way.

- Production preparation
  - Storage of materials in the stockyard
  - Surface preparation
  - Cutting and drilling
  - Bending
- Assembly of the parts
- Welding
  - Fluxcored arc welding (FCAW)
  - Submerged arc welding (SAW)
  - Shielded metal arc welding (SMAW)
- Surface treatment
  - Shot blasting
  - Hot dip galvanization
  - Painting
- Quality control

#### **i. Production Preparation**

##### **▪ Storage of materials in the stockyard**

Stockyard is an unit where the raw materials, standard cut pieces and sections, weld materials and all the productions things that is required for the production will be stored, so as to supply the required supplements for the production sequence. Since, production

is continuous and rapid process the stockyard should have all requirements ready prior to the start of any project or production.

- **Surface preparation**

Surface preparation for beams, plates and sections is an important process because it provides an essentially suitable clean surface to support welding.

- **Cutting and drilling**

Cutting of section plates to desired length and shape and drilling of holes and cut lengths on the section plates will be carried out by automated machinery.



Figure 50: Section plate cutting machine (Elctrofer Group, 2017)



Figure 51: Drilling machine (Elctrofer Group, 2017)

## **Bending**

Bending is a process to make curvatures to the plates or beams. To obtain special curvatures to the plates or beams, the plates or beams will be sent to a specialised operator. This process involves bending of sections through a set of bending rollers that can be shaped to the cross section of the beam or plate. On each pass through the rolls more bend is created and this process is repeated until required shape is achieved.



**Figure 52: Bending machine** (Elctrofer Group, 2017)

### **ii. Assembly**

Assembly of the parts are done according to the 2D drawings. The parts are assembled as per the dimensions given in the drawing and are sent for welding.

### **iii. Welding**

Welding is the core of steel structure production. Welding is a process that uses an electric arc to generate heat to melt the molten material in the joint and the filler material. Welding uses a filler material as an electrode which also melts with the parent material to form a molten pool. Weldpool is very susceptible to atmospheric contamination and hence a protective shielding inert gas is used to protect the weld pool from atmospheric contaminations when the weld solidifies, for example, Argon and carbon-di-oxide (CO<sub>2</sub>) is used as a shielding gas in Metal active gas welding (MAG).

Due to the advancement in the technology of the welding process complex structures can be built easily. There are varieties of welding process used in the construction of steel structures but some of the common processes are explained below.

#### **▪ Flux Cored Arc Welding (FCAW)**

FCAW is abbreviated as Flux Cored Arc Welding (FCAW). FCAW is a semi-automatic welding process; FCAW uses a continuously fed consumable tubular electrode containing flux.



**Figure 53: Flux cored arc welding** (Elctrofer Group, 2017)



**Figure 54: Flux cored arc welding machine** (Elctrofer Group, 2017)

- **Submerged Arc Welding (SAW)**

Submerged Arc Welding is a common arc welding process. It is a mechanised type welding process and it requires a welding operator. SAW involves the formation of arc between a continuously fed electrode and the workpiece, powdered flux is fed during the welding which generates a protective shield and the slag protects the weld zone. A shielding gas is not required.



**Figure 55: Submerged Arc welding process** (Elctrofer Group, 2017)

- **Shielded Metal Arc Welding (SMAW)**

Shielded Metal Arc Welding (SMAW) or manual metal arc welding is a common arc welding process which uses flux coated consumable electrode to lay the weld. Welding is performed by the generation of electric arc between the electrode and the metal. Arc is generated between two conductors, cathode and anode, when they are touched at a small distance there is a flow of electric current, which in turn produces heat. The heat produced is sufficient to melt the base material, electrode rod and the flux coating. Flux coating is used as a shield to protect the welding from atmospheric contaminants during solidification and also provides good metallurgical properties to the weld.

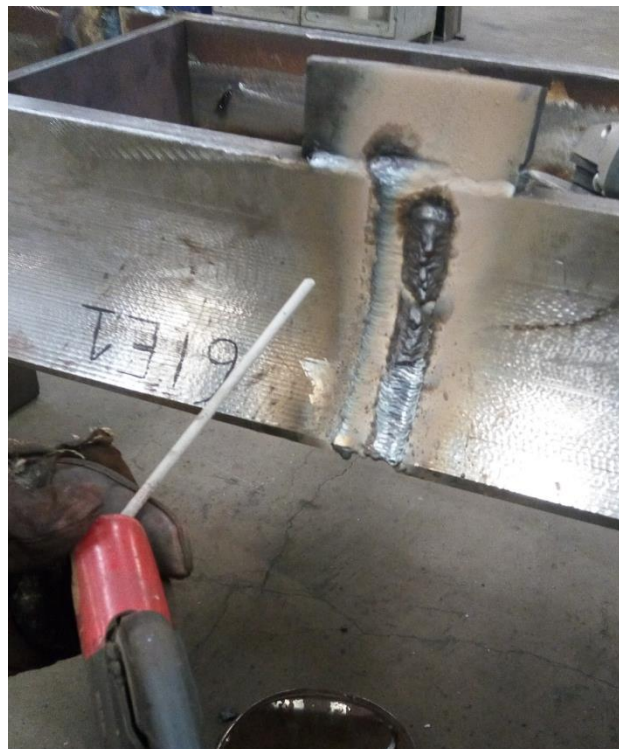

**Figure 56: Shielded metal arc welding process** (Elctrofer Group, 2017)

#### **iv. Surface treatment**

Surface treatment is a process that is basically done to protect steel from corrosion and improve the surface property of the material. Surface treatment process is done to the components made out of metals or plastics in order to improve the life cycle of the component and surface treatment is done before any coating is applied to the metal surface. Surface treatment is done to the metals because it creates a barrier that acts like a wall protecting the metal from an environment that is corrosive and also surface treatment increases the surface quality of the metal, so that coating or painting can easily adhere to the surface of the metal.

##### **▪ Shot blasting:**

Shot blasting is a surface treatment process where the component is bombarded with high speed steel abrasives. Shot blasting uses a turbine to accelerate the abrasives over the component. Shot blasting uses centrifugal force of the turbine to shoot the steel abrasives over the component. Due to the heavy bombarding and cutting force on the surface of the component, the surface of the component is cleaned and the parts are treated which will be ready to accept the paint.

##### **▪ Hot dip galvanization**

Hot dip galvanization is a surface treatment process of coating iron and steel with a layer of zinc by immersing in a metal bath of molten zinc at a temperature of 449°C. When exposed to atmosphere, Zinc reacts with oxygen to form zinc oxide (ZnO), which further reacts with carbon-di-oxide to form zinc carbonate (ZnCO<sub>3</sub>) ("GalvInfoNote / The Spangle on Hot-Dip Galvanized Steel Sheet", 2011) .

The coated steel with zinc will usually have a fairly dull grey colour, which is strong and zinc protects the steel underneath from corrosion.

Welding steel that is coated with zinc some precautionary measures have to be taken because of the resulting zinc toxic fumes.

In this process, there is a strong relationship between zinc and steel because zinc protects the steel from atmosphere. The operation of coating steel with zinc is explained below.

- a. Firstly, the steel has to be cleaned with caustic solution to remove dirt, grease, oil etc.
- b. The cleaning solution will be rinsed off
- c. Pickling process is adopted to remove the impurities, stains, rusts, inorganic contaminants etc
- d. Pickling solution will be rinsed off
- e. Zinc ammonium chloride is applied on the steel in order to prevent the steel surface from oxidation.
- f. Now, the zinc is immersed in a bath of molten zinc and held there until the steel inherits the temperature with that of the zinc bath.
- g. The steel is rapidly cooled in a quenching tank in order to inhibit the reactions that may occur in the presence of air.

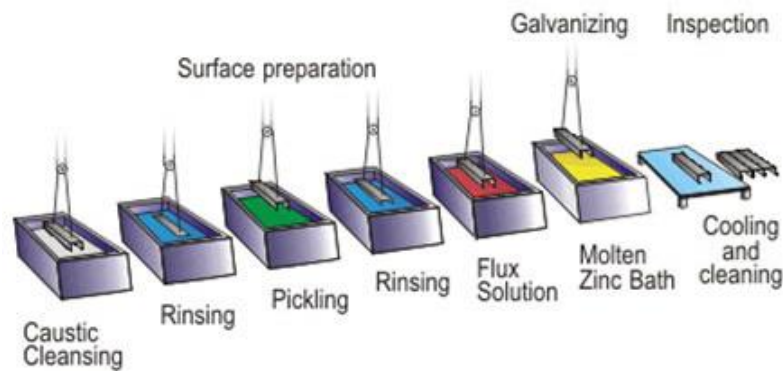

Figure 57: Hot dip galvanizing process (Hot Dipped Wire Galvanizing Line)

- **Painting**

Painting is most commonly used process to protect steel from corrosion. Painting improves the durability of the steel and adds colour to the steel structures. Painting is done with accordance to the standard ISO 12944. The standard ISO 12944 also recommends the thickness of the paint and also the number of coatings to be applied other than selecting paints and their grades. The painting method (paint scheme) depends on the type of environment and purpose of the structure.

- v. **Quality control**

Quality control is done to prevent mistakes or defects in manufactured parts and ensuring that the products meet certain standards of quality. The standard of quality is a document that contains all the information that is necessary for construction and erection of steel structures. Hence, all the steel structures produced will be in conformity which is related with the standards of quality. All the structures built will be subjected to destructive or non destructive inspections especially for welds because welding is the core of steel structure production. Usually, non destructive testings will be performed. The results of the non- destructive tests, functionality tests and other tests relating to the inspection of steel structures will be documented. Sometimes, it becomes necessary to control the dimensions of the parts in order to check whether the parts are assembled according to the dimensions in the drawing. If they are not matching the requirements of drawing then it is sent back for repair and is termed as non- conformity. Non conformities will be documented in order to find out the loss of time and cost during construction of the part.

## **6. Department of painting**

### **6.1. Introduction to Painting:**

Painting is applied to protect steel from corrosion and to provide appearance. Corrosion costs vast damages to the steel structures and hence, steel structures have to be protected from corrosion. In this report, a case study has been made on corrosion, protecting metallic materials from corrosion, painting and its applications, paint coating failures, use of painting standards, procedures & documentations and inspection methods.

### **6.2. Corrosion:**

Metallic materials get corroded because they are used in an environment where they are chemically unstable. Corrosion of metals happens due to chemical or electrochemical reaction. Chemical corrosion is due to oxidation which occurs by the action of dry gases. Electrochemical corrosion occurs due to electrode reactions especially in humid environment and is termed as wet corrosion.

In the above statement, explanation has been given on how corrosion occurs but it also very important to understand why corrosion is a serious problem?

- Corrosion damages the material and the material loses its strength because of the oxides that are formed on the metal, the metal oxides weaken the metal bonding and the material will be unfit for further use. For example, if a bridge is constructed and the metal corrodes, the bridge would flake away and eventually snap because the material becomes brittle and the structural integrity is lost.
- Corrosion shortens the life span of the metal.
- Corrosion not only damages the metal structures, it also contributes towards the breaking down of concrete or plastic surrounding the metal structure. So, this results in permanent failure of steel structures.
- If pitting corrosion exists in a steel structure it leads to the formation of holes. Pitting is a serious problem because it causes the loss of metal thickness because the corrosion bores inwards and it also leads to stress cracking.

Hence, due to corrosion deterioration of the metal takes place and there will be permanent failure of the sections. Hence, it is very important to protect metals from corrosion. In order to protect metals from corrosion- paints or coatings or some barriers are used to stop any direct contact between the metal and the environment that is corrosive. Based on the type of attack on metals, corrosion is classified depending on the characteristic of attack and the damage it contributes to the metal.

Some corrosion types are explained below-

**i. Uniform corrosion**

When corrosion occurs approximately at the same rate over the metal surface, it is called uniform corrosion. Uniform corrosion does not cause much damage; technically speaking this corrosion is not very problematic. This type of corrosion fairly results in the breakdown of metal. If this type of corrosion occurs approximately at an average rate of 0.1mm/year then it would take 20years to corrode 20mm thickness of the metal to get damaged completely (Dag Kjernsmo, 2003). Uniform corrosion can be prevented by selecting the right material, using cathodic preventions, using inhibitors, using coatings or linings.

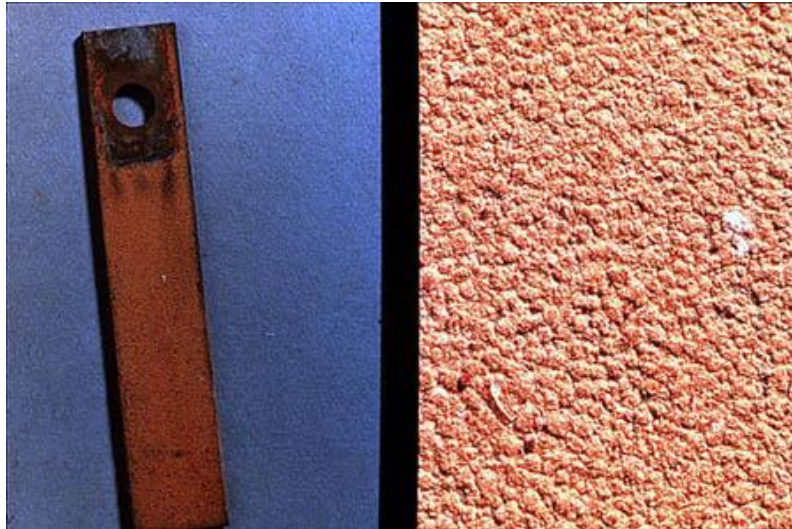

**Figure 58: Uniform corrosion on steel** (Uniform corrosion on mild steel)

**ii. Crevice corrosion**

Crevice corrosion usually occurs on metals that are passive, such as stainless steel, aluminum, steel etc especially in an alkaline environment. Crevice corrosion usually occurs when the liquid, especially water solutions becomes stagnant in the narrow crevices. The cause of this corrosion is due to the difference in oxygen content inside and outside the crevice. Crevice corrosion can be eliminated by using weldings instead of bolting or riveting in the places applicable; minimizing the sharp edges; by minimizing the number of liquid pockets.



Crevice

**Figure 59: Crevice corrosion** (Stainless Steel and Corrosion, 2015)

### iii. Pitting corrosion

If pitting corrosion exists in a steel structure it leads to the formation of holes. Pitting is a serious problem because it causes the loss of metal thickness because the corrosion bores inwards and it also leads to stress cracking. The diameter of the pits maybe relatively small but they grow deeper and damage the metal for greater extents. The main drawback of this type of corrosion is sometimes the corrosion closes the pit holes and it would be very difficult to spot the pits. Pitting corrosion can be reduced by selecting the appropriate type of material according to the type of environment, by applying surface barrier to the metal so the metal does not come in contact with the environment.

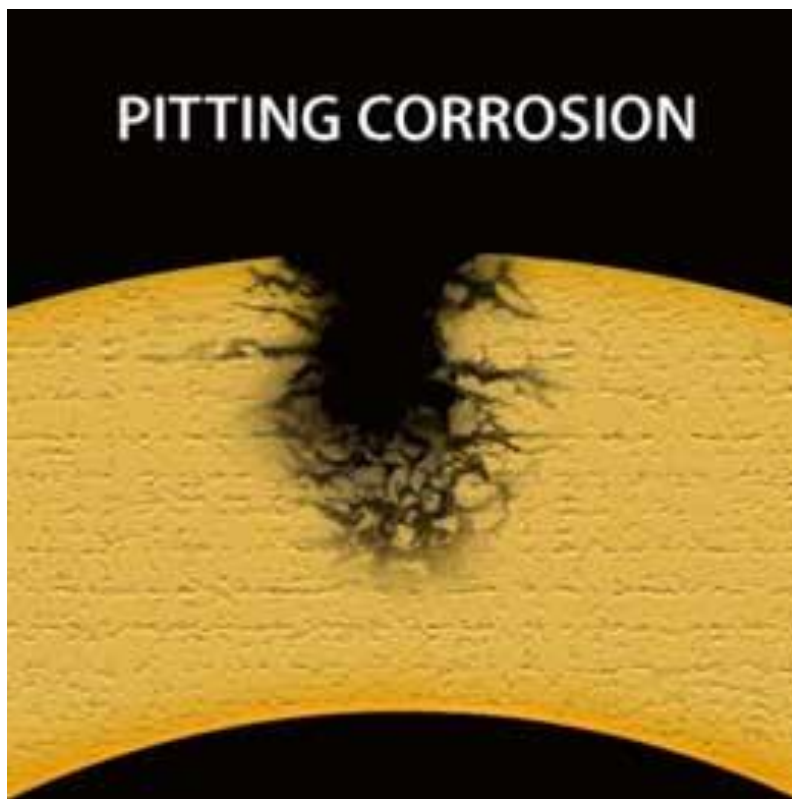

**Figure 60: Pitting corrosion** (Strategies for Combatting Coil Corrosion, 2010)

### iv. Erosion corrosion

Erosion corrosion occurs when the metal is subjected to mechanical abrasion and to the environment that is corrosive. This type of corrosion occurs usually when the construction is made by a poor design and uneven welding. Erosion can be reduced by adopting stable construction design, by following proper welding procedure specifications during welding, by suitably choosing proper painting parameters for that particular environment. The corrosion defects will produce a distinctive surface finish like grooves, gullies, waves etc.

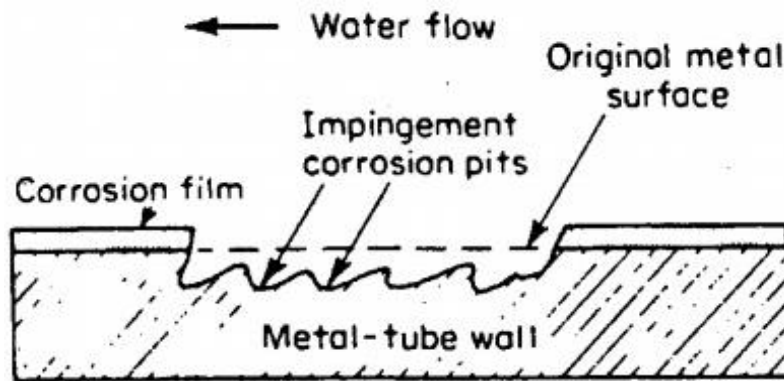

Figure 61: Erosion corrosion in a tube wall (Sharma)

### 6.3. Protection against corrosion

We know that corrosion causes vast sums to the metal acquisition and metal construction industries. If corrosion is not treated they also cause vast damage to the steel structures that are erected and the failure of the structure takes place. Some major steps have been adopted to protect steel from corrosion, they are:

#### ➤ **Selecting the right choice of material depending on the environment**

Selection of material according to the type of environment is very important and also many factors would appear while selecting right type of material. While selecting material one should also consider life span of the material and flexibility to access the replacement of the materials. Basically materials selection will be based on corrosion resistance and economy. Many handbooks and material selection tables have been formulated for the selection of materials based on the type of environment, compositions used while alloying steel, annealing temperatures etc. Composition and temperature may affect the rate of corrosion; hence, important procedures and operations are to be adopted to impart the potential deviations while selecting the right compositions for the metals. Various tests are available to determine the corrosion rate.

#### ➤ **Using stable/ appropriate construction designs**

Corrosion can be prevented at early stages by using stable and appropriate design techniques. Unappropriate designs will cause water, dirt and pollutants to get entrapped in the materials which cause corrosion. Hence, it is important to prevent corrosion at early stages i.e by adopting stable design techniques. Crevices can be formed in different ways but care should be taken during construction design so, that there won't be any spaces for the crevices to be formed, for example: if two metal sheets are attached using fastening methods such as bolting or spot welding then there will be a narrow opening for the pollutants or moisture to accumulate then this will cause problems. Corrosion will start to build in these narrow openings. Usually rust causes a serious problem, in actual fact rust takes up larger volume than steel. The rust that is formed from actual steel will cause the steel to deform. Hence, it will be a better option to use continuous welding where applicable while joining two metal sheets or beams.

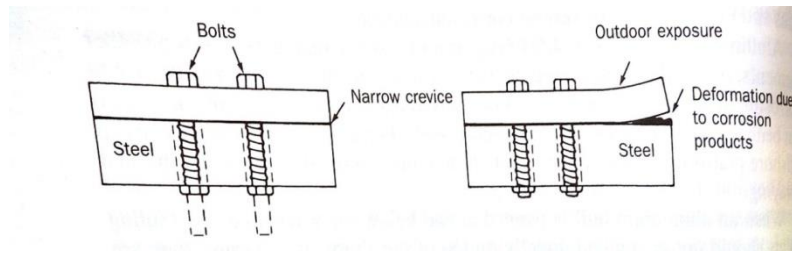

**Figure 62: Corrosion products will have volumes higher than steel and cause deformation** (Dag Kjernsmo, 2003)

It would be very convenient to use simple geometrical designs because simpler geometrical designs make it convenient to apply paint or carry out surface treatment process. Many problems arise due to the variation of the profile shapes. Sometimes, it would be better to make a round edge profiles than sharp edges because round corners will have more even and uniform surface area to apply paint and carry out surface treatment process.

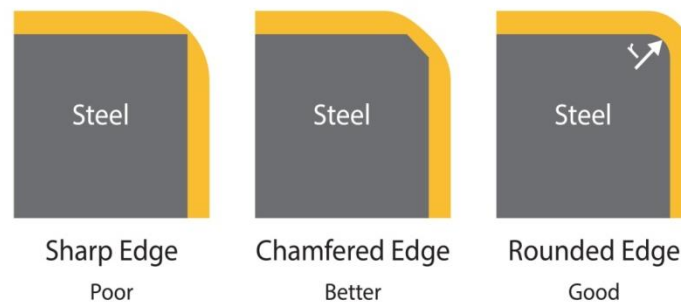

**Figure 63: Sharp edges to be rounded to obtain uniform and thick paint coat thickness** (Dag Kjernsmo, 2003)

In case of fluid carrying structures (for example: heat exchanger pipes should have suitable design so that there is no turbulence created during the transfer of fluid). In case, the design is not stable and the if turbulence is created then erosion corrosion may arise, hence, during design of fluid carrying pipes it would be better to avoid right angle corners and better to have smooth gradual dimensions.

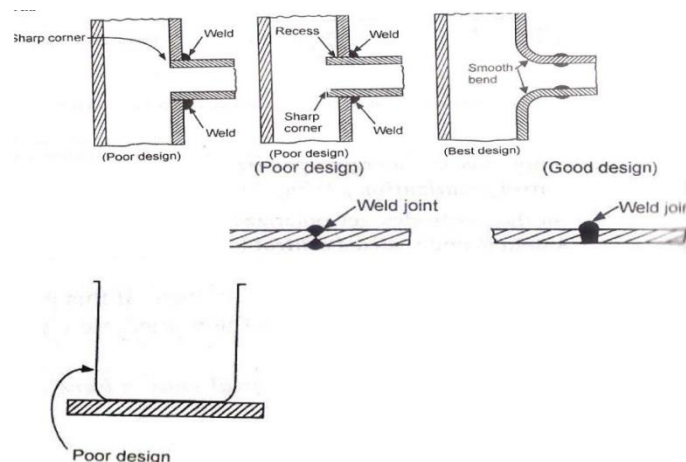

**Figure 64: Right angled bends to be eliminated to avoid turbulence which may cause corrosion** (Dag Kjernsmo, 2003)

➤ **Use of corrosion barriers like paints or varnishes**

Paints or varnishes are commonly used corrosion barrier to protect metal from corrosion. By the application of paint, a film is built up that protects the metal from getting in contact with the environment that is corrosive. Paints not only protect metal from corrosion they also provide appearance to the metals. Paints are said to protect the metal in different ways and some are as follows:

- Paints as a barrier protection – paints avoid water and air to get in contact with the metal i.e they act as a barrier that the moisture and pollutants does not come in contact with the metal surface.
- Paints are mixed with some pigments to protect the metal surface underneath from corrosion.
- Paints also protect the metal by sacrificing themselves. These sacrificing paints are Zinc rich paints. Zinc sacrifices themselves to protect the steel from corrosion.

Painting systems follow some standards and paints must be selected as per the requirements in the standards.

➤ **Protection from electrochemical corrosion**

Corrosion occurs in metals due to oxidation on anode and reduction on cathode. Metal acts as anode because metal is oxidized and the metal forms oxide ions and set the electrons free. These free electrons reduce oxygen forming hydroxides. This process is called cathodic reaction (Dag Kjærnsmo, 2003). If further oxidation of the metal takes place, pits form on the metal surface causing pitting corrosion. Pitting corrosion causes serious damage to the metal surface.

Electrochemical corrosion can be reduced by making the metal negative i.e making the metal cathodic. The metal can be made cathodic by applying impressed current from a DC power source from an auxiliary electrode and also there are other methods to reduce electro chemical corrosion.

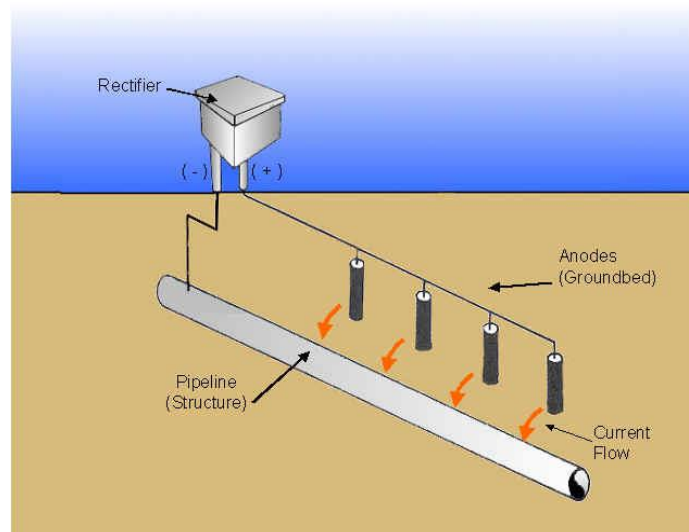

**Figure 65: Cathodic protection** (Cathodic Protection Systems and Repairs)

## 6.4. Paint coatings

Paint is a coloured pigment that is applied on top of a material surface which forms a thin protective layer. Paints are applied over metal surfaces to protect the metals from corrosion. It acts like a barrier between the corrosive environment and the metal. Paint not only protects steel from corrosion but it also provides decorative layer or good appearance to the metal structures. Paint selection depends on the environment that it is being used and standards must be followed for its selection and application. Paints are basically determined by their binder material. The binder material signifies the type of paint being used and is referred to as generic type. Paints may be of different generic types. Some paints may contain zinc powders as pigment and others may not contain zinc powders and these may be considered as different generic type. Some properties also may vary in the paint types because the materials may be purchased from different suppliers. Paint is determined by the ratio between the binder, pigments or extenders used in them and the important factor to be considered while selecting paint is Pigment Volume Concentration (PVC). Pigment volume indicates the amount of pigments and extenders contained in the paint. When Pigment Volume Concentration is high the paint will have less glossy finish instead the paint will have a matt finish. The formula to calculate PVC is

$$PVC = \frac{VOLUME\ OF\ PIGMENTS\ AND\ EXTENDERS}{SOLID\ VOLUME\ (TOTAL\ VOLUME\ OF\ WET\ PAINT)} * 100 \text{ (Dag Kjernsmo, 2003)}$$

Usually paint system composes of three layers i.e. the primer, the intermediate coat and the finishing coat. These composition may not be always true sometimes there maybe two coats and sometimes just a single coat. The three layers have their own purpose. The primer coat ensures good adhesion to the substrate, the intermediate coat helps to build up the paint thickness and the finish coat provides the surface with required colour and gloss and is the final coat that is exposed to sun, rain, chemicals, dust etc.

## 6.5. Composition of paint

Paints are composed of various components depending upon the generic usage. Paint systems have binders, pigments, extenders, solvents and other additives.

### ➤ Binders

Binders are the substance that determines the properties of paint. The main purpose of binder is to ensure that the paint has good adhesion properties to the substrate and to ensure that the added pigments to the paint are bound together.

### ➤ Pigments

Pigments are the substances that protect binder from being broken down by ultraviolet rays and pollutants. Pigments impart colour to the paint and provide opacity. Pigments also possess anti-corrosion prevention, usually pigments are mixed with primers.

➤ **Extenders**

Extenders are the substances that increase bulkness to the paint (i.e. they provide body to the paint). Extenders do not give colour to the paint but they contribute in providing good adhesion properties to the paint, they increase in providing hardness to the film.

➤ **Solvents**

Solvents help in spreading the paint evenly over the surface because when just binders and solvents are mixed the mixture becomes gloopy and will be difficult to apply. Solvents dissolve the binders such that suitable viscosity is obtained while spreading the paint uniformly. Not all the solvents dissolve binders the paint chemists should know which solvents dissolve the binder and in what ratios they are to be used. Solvents are volatile particles. They evaporate from paints quickly. The evaporation of solvents depends on their boiling points. Higher the boiling point slower is the evaporation. Paints become dry when the solvents are evaporated. Hence, they are known as physically drying paints.

➤ **Additives**

Additives serve as different purposes and they are different types. Addition of additives depends on the purpose of utilization. Additives are added for outdoor environment to which can serve for special purposes to make things waterproof, protection from rust, from frost sunlight, to improve strength and life span of paints etc. For example: addition of ceramic powders helps the paint to improve its strength and durability.

## **6.6. Types of Paints**

Paints are classified according to their usage. There are varieties of paints available in the market each having their own specifications. Specifications depend on the binder, pigments, solvents and additives used. In this explanation not many paint types are explained but some paint types that are used widely have been explained.

• **Primers**

Primers are the coats that are applied on the surface of the metal and are termed as the first coat. Primers provide good adhesion to the upper layers of the paint, they contain corrosion protection pigments. Paints containing corrosion protection pigments are used in primer coats and basically they are enriched with zinc and are called Zinc rich paints. There are variety of primers depending on the application of usage and they are classified as:

- a. Organic zinc rich paints
- b. Inorganic zinc rich paints
- c. Zinc alkali silicate

• **Shopprimers**

Shop primers are applied at the beginning of the fabrication. Steel sheets or profiles are cleaned using shot blasting, in shot blasting metal abrasives are bombarded on the surface of the metal and shopprimers are applied over the surface. Shop primers are available in variety of types with different binders and corrosion protection pigments.

After applying shop primer it must be possible to weld and there must be problem from the shop primer. In case if a problem persists the shop primer area can be cleaned before welding.

- **Physically drying paints**

Physically drying paints are those that are dried by evaporation without the influence of any chemical reaction during the process of drying. The evaporation is high at higher temperatures and lower at low temperatures.

- **Acrylic paints**

Acrylic paints are water soluble paints. These paints are very good sunlight and water resistant. These paints are used where glossy appearance is required.

- **Oxidatively curing paints**

These are the paints that are solidified by the reaction with oxygen. These paints are chemically cured during solidification. The binder used in this paint will be based on the content of drying oil. Drying oils have the tendency to hold oxygen molecule in the air and thereby react with them and build a network of several fatty acid chains to get cured.

- **Chemically curing paints**

Chemically curing paints are those that are dried by the chemical reaction between two components. Chemically curing paints are delivered in two containers hence, it is called two component paint. The two components are base and the curing agent. Before starting to paint the two components should be mixed at right proportions, the mixing proportion ratio will be indicated in the paint containers or in technical sheet of the paints. No excess base should be added to agent or more agents to be added to the base. The composition mixture should be at right proportions for the curing to take place properly.

- **Siloxane paints**

Siloxane paints are hybrid paints. These paints have inorganic binders. These paints can be made to chemically react with acrylics or other components. They provide excellent glossy finish to the surface. Siloxane is a substance related to silicates and silicones.

## **6.7. Paint coating failures**

Paint coating failures takes place due to many reasons. Some of the paint coating failures may be difficult to avoid even for the painter who is highly skilled in painting. Paint coating failure occurs because of the poor application of paints insufficient cleaning of the surfaces, presence of oil or grease on the surface before applying paint, having sharp corners or edges will possess major problems etc. Now we will be discussing about some types of paint coating failures.

➤ **Failure due to loss of adhesion**

**a. Peeling**

Peeling is often due to the case of improper adhesion, this happens due to improper cleaning of the surface. In this case one coating of the layer is removed from other layer, the layers peel off in the form of flakes. There is variety of reasons for peeling to occur. Peeling also occurs due to time lapse, i.e if there is too long delay for the application of the paint from one layer to another. If the paint gets peeled off from the surface then the coat has to be removed all the way down to the surface of the bare material but in some cases just grinding would be preferable.

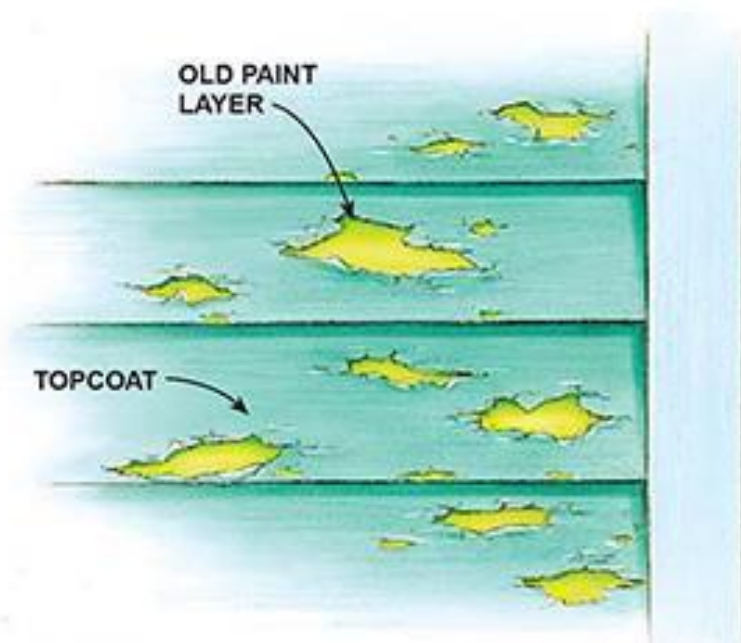
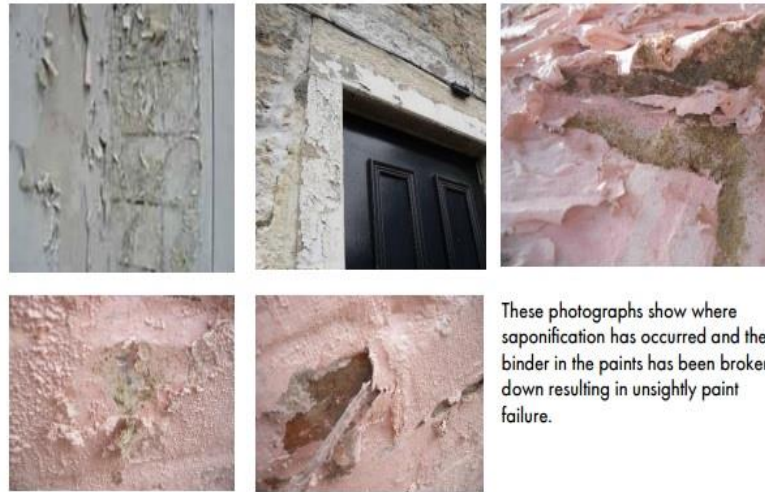

Figure 66: Peeling of paint (CAUSES OF PEELING PAINT, 2017)

**b. Saponification**

Saponification is a destructive painting failure, which results in the loss of adhesion. Saponification occurs usually in the oil based paints that contains alkyls and the failure takes place when they are exposed to moisture or alkaline environment. Discolouration of the paint takes place and the paints come out in the form of flakes.



**Figure 67: Saponification** (Scott's Painting & Staining Inc.)

➤ **Failures on surface of the paints**

Failures of paint coatings occur for many reasons and major failures occur due to improper cleaning of the surfaces before applying paint coatings. Some of the failures due to defects in the surface are explained below.

**a. Voids and blistering**

When the paint coatings are applied unevenly solvents or air gets trapped on the coating films these entrapped solvents or air in the coating film may attract moisture and causes blistering in the coating film. The areas where dry thickness is reduced will become weaker and may result in loss of adhesion. When blisterings are found during application of paint the painting has to be stopped immediately. Any defect found in the coating area must be removed and new coating has to be applied.

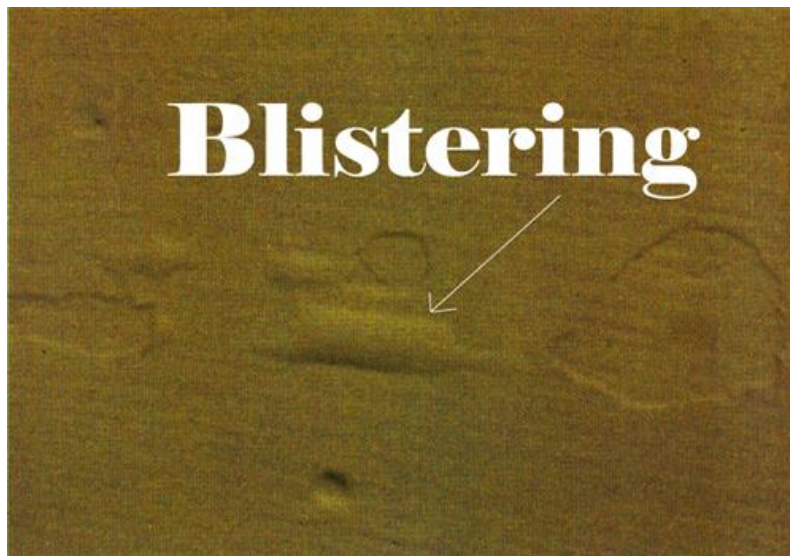

**Figure 68: Blistering due to entrapped air or solvents in the coating** (Davi PAints, 2009)

### **b. Popping or Craters**

Popping is a failure of the paint coating system, popping occurs at the time when the solvents or air escape the wet film when the evaporation is already high and the coating will no longer be able to form a coherent film. The solvents or bubbles pop out of the paint coating forming craters.

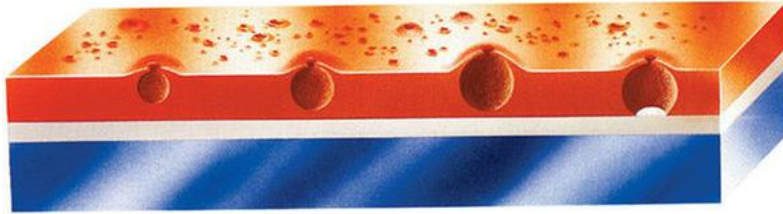

**Figure 69: Formation of craters** (Hot Rod, 1993)

### **c. Cracking**

Cracking of paint coating occurs due to lack of adhesion or if the paint is applied too thin or if there is no proper treatment of the surface before applying coat. Cracking usually happens in oxidative or chemically curing paints. Repairing of these coatings will depend on how deep the crack goes down.



**Figure 70: Cracking of paints** (Acrylatex Coatings & Recycling, Inc. , 2011)

#### **➤ Failures during application of paints**

##### **a. Dry spray**

Dry spray occurs when the paint is applied from too long distance. Before the paint reaches the surface some of the solvents get evaporated from the spray gun and the paint loses its film forming properties and the paint becomes dry and rough. The appearance may look like sand paper. The damage caused by this failure can be repaired by carefully applying a suitable thinner or by applying a new layer of thin coat.

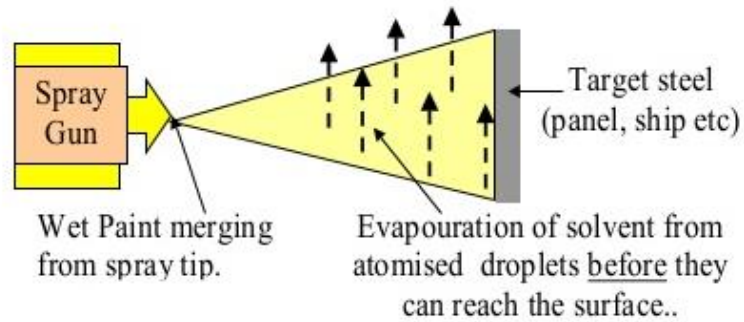

Figure 71: Solvents disappearing from the spray before it reaches the surface (Coating defects)

### b. Orange peel

This type of failure occurs due to low pressure or low viscosity of the paints and it may be also due to fast evaporation of the solvents. The coats get of the surface like an Orange peel. This kind of failure will have rough and uneven surface. Orange peel can be repaired by grinding or abrasive blast cleaning before the application of new coat.



Figure 72: Orange peel (Orange Peel)

## 6.8. Painting Standards

Paint coating systems follows EN ISO 12944 Standard. This Standard has 8 parts and each part having its own significance. ISO12944 will guide engineers and corrosion experts to adopt best practices to protect steel structures at constructional work. This standard only deals with paints and varnishes. EN ISO 12944 explains selection criteria for paints, their applications, corrosion protection, coating design, a specified matrix to select the coating system etc.

➤ **EN ISO 12944-1**

EN ISO 12944-1 (part 1) gives the general description about protection of steel from corrosion, functions of paint systems, the field of applications, type of structure used, type of surface preparation, type of paint systems to be used in different environments, maintenance of the paint system, durability of the paint system etc (Dag Kjærnsmo, 2003).

➤ **EN ISO 12944-2**

EN ISO 12944-2 (part 2) defines the classification of the environments in which the steel structures are exposed and corrosivity of those environments. This standard describes the loss in the mass of the material due to corrosion. The corrosion stress due to the atmosphere, water and soil are explained (Dag Kjærnsmo, 2003).

• **Atmospheric corrosion**

Atmospheric corrosion is due to relative humidity, due to the occurrence of condensation and pollution in the atmosphere. This type of corrosion occurs on the surface of the metal as a thin film and is not visible to the naked eye. Atmospheric corrosive categories are classified into six types and they are:

**Table 1: Atmospheric corrosivity categories and their influence on typical environments** (Dag Kjærnsmo, 2003)

Corrosivity category	Mass loss per unit surface/thickness loss (after first year of exposure)				Examples of typical environments in a temperate climate (informative only)	
	Low-carbon steel		Zinc		Exterior	Interior
	Mass loss g/m <sup>2</sup>	Thickness loss µm	Mass loss g/m <sup>2</sup>	Thickness loss µm		
C1 very low	≤ 10	≤ 1,3	≤ 0,7	≤ 0,1	—	Heated buildings with clean atmospheres, e.g. offices, shops, schools, hotels.
C2 low	> 10 to 200	> 1,3 to 25	> 0,7 to 5	> 0,1 to 0,7	Atmospheres with low level of pollution. Mostly rural areas.	Unheated buildings where condensation may occur, e.g. depots, sports halls.
C3 medium	> 200 to 400	> 25 to 50	> 5 to 15	> 0,7 to 2,1	Urban and industrial atmospheres, moderate sulfur dioxide pollution. Coastal areas with low salinity.	Production rooms with high humidity and some air pollution, e.g. food-processing plants, laundries, breweries, dairies.
C4 high	> 400 to 650	> 50 to 80	> 15 to 30	> 2,1 to 4,2	Industrial areas and coastal areas with moderate salinity.	Chemical plants, swimming pools, coastal ship- and boatyards.
C5-I very high (industrial)	> 650 to 1 500	> 80 to 200	> 30 to 60	> 4,2 to 8,4	Industrial areas with high humidity and aggressive atmosphere.	Buildings or areas with almost permanent condensation and with high pollution.
C5-M very high (marine)	> 650 to 1 500	> 80 to 200	> 30 to 60	> 4,2 to 8,4	Coastal and offshore areas with high salinity.	Buildings or areas with almost permanent condensation and with high pollution.

• **Water and soil corrosion**

Some steel structures are buried partly under water or under soil during erection. These partly exposed steel structures to these environments are highly corroded. In water the corrosion may be influenced due to the oxygen present in water, animal or vegetable growth may increase corrosion and in soil is due to mineral content in soil, organic matter water content etc.

➤ **EN ISO 12944-3**

This part explains the design criterias of steel structures for paints to be coated by protective paint systems to avoid premature corrosion and degradation of the coating. Corrosion can be prevented at early stages by using stable and appropriate design techniques. Unappropriate designs will cause water, dirt and pollutants to get entrapped in the materials which cause corrosion. Hence, it is important to prevent corrosion at early stages i.e by adopting stable design techniques and this standard explains clearly about the design selection. The design considerations and usage of appropriate designs has been clearly explained in protection against corrosion- Using stable/ appropriate construction designs (Dag Kjernsmo, 2003).

➤ **EN ISO 12944-4**

This part explains about the types of surface and their preparation. This standard explains about carbon or low alloy steel and their surface preparation. This part deals with the surfaces that have uncoated surfaces, hot-dip galvanized surfaces, surfaces thermally sprayed with zinc, aluminum or their alloys, surfaces painted with primers etc. For surface preparation abraive blasting cleaning, chemical treatments, thermal treatments etc are allowed (Dag Kjernsmo, 2003).

➤ **EN ISO 12944-5**

This part is titled as protective paint systems. This part of the standard describes the types of paints and the paint system used for corrosion protection depending on the environment. It also guides us to select right type of paints for different environments. Paint systems will be based on the type of environment, type of primer used, dry film thickness and durability (Dag Kjernsmo, 2003).

➤ **EN ISO 12944-6**

This part of the standard explains about the performance test carried out in laboratories. The results obtained from these test are to be considered to select the paint system for that particular environment. The reason to perform this test is to determine the durability of the paint. The test is carried out to recognize whether the paint system can withstand to the external factors such as environmental corrosion. The durability of the paint depends upon the chemical and physical characteristics of the paint system. The chemical and physical system can be evaluated by artificial ageing tests. These tests will be carried out to determine whether the paint system is resistance to water, moisture, pollutants etc. but fact to be note that these tests will not have the same effects as in nature. There are some chemical tests that will be carried out to determine the more adverse effects of corrosion over the paint system (Dag Kjernsmo, 2003).

➤ **EN ISO 12944-7**

EN ISO 12944-7 deals with Execution of painting and supervision of paint work. This standard explains execution of paint work and methods of supervision of paint work for the steel structures either at shop or onsite.

Execution of painting will include some verification before the application of the paint such as the conformity of the container label, no skin formation, usability under the

given site conditions, to remove sediments if they are present. Execution of Paint coating should not be applied at the temperatures 3°C above the dew point. Wet coatings can only be applied as specified in the paint technical data sheet and should not be applied when it is not permissible.

Supervision of paint work will be carried out in every stage of paint applications. Supervision will only be carried out by qualified and experienced people. The supervision of painting will depend on the importance of the Project, the conditions where the structure will be erected, the type of coating that is applied. Supervision will include checking of the paint coating visually and by use of some instruments to measure the dry or wet film thickness (Dag Kjernsmo, 2003).

➤ **EN ISO 12944-8**

This part of the standard explains about the development of specifications for execution of new work and maintenance. According to this standard to develop a new work for application of paint some parameters are to be considered. They are:

- i. Durability of the paint
- ii. Environmental condition and corrosion stress
- iii. Surface preparation
- iv. Different generic types of paints
- v. Number and types of coats
- vi. Methods of application and their requirements
- vii. Place of application
- viii. Maintenance
- ix. Health and safety requirements

A draft has to be made stating the considerations of these requirements and after deciding the factors. The applications of paints must be started with the specifications for execution of new work. The maintenance and supervision of the paint work will be according to the standard EN ISO 12944-7 (Dag Kjernsmo, 2003).

## **6.9. Procedures and documentations**

Procedure is a document which is an answer to the paint specifications. Procedure contains all the details on how the surface preparation will be carried out, how the paint coating system will be applied, and person responsible for quality. In procedure document, the corrosion inspector will provide details about the corrosion control routines, the person in charge of applying paints to show that the company is capable of fulfilling the requirements of the standard specifications. The procedures will be maintained as a report. These reports are in connection with quality control so that all the requirements for fulfilling the painting quality will be achieved. The reports will be comprised of company procedures, daily log, treatment progress report, non conformity reports etc.

- **Company procedures**

Company procedures will include some set of preparations that will be considered for painting. The preparations will be recorded by the persons of quality assurance and control. The company procedures include pre-blasting preparations and surface

preparations. Later painting is applied to the surface according to the technical specifications. The records maintained as documents will have all the information right from the beginning of the preparations to the application of paints.

In pre-blasting preparations records are maintained to ensure that there is any damage to the structural surfaces, tubes etc and to ensure that the damaged surfaces are finely grinded. To ensure the structural surfaces are free of oil or grease before the blast cleaning. All these information are recorded as daily log.

**a. Surface preparation**

All the information regarding surface preparation are also maintained in a daily log to make note of the start and end date of the blast cleaning, the type of abrasive used, grain size of the abrasive, cleanliness and roughness of the steel.

**b. Painting**

Paintings are also recorded as daily log to figure out the relative humidity, air temperature, metal surface temperature, dew point temperature etc. Records are also maintained after application of paint layers to note the wet and dry film thickness, adhesion, appearance etc. The reported log is a very important document about the work carried out and probably maybe an important document to show it to the customer in case of complaint.

**Table 2: Daily record of paint applications** (Electrofer Group internal document.)

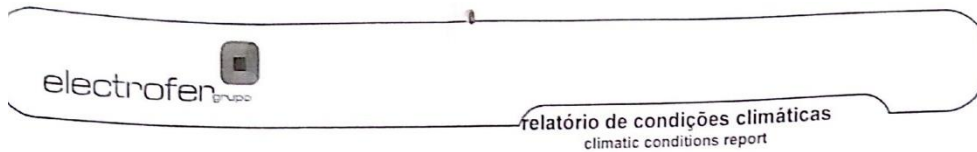

Hora/ Data Time/ Date	Produto controlado Product	Temperatura Ar Dry temperature	Humidade relativa Ar Relative humidity	Temperatura Ponto Orvalho Dew point	Temperatura Peça Surface temperature	Decisão Decision	Rubrica Signature
09:00 17/4/17		18,7°C	65,3%	10,2°C	18,0°C	ok	<i>[Signature]</i>
11:00 17/4/17		18,6°C	58,9%	10,4°C	17,9°C	ok	<i>[Signature]</i>
14:00 17/4/17		21,8°C	58,8%	11,6°C	20,5°C	ok	<i>[Signature]</i>
17:00							
09:00 19/4/17		13,5°C	57,9%	11,0°C	19,0°C	ok	<i>[Signature]</i>
11:00 19/4/17		23,4°C	50,5%	11,5°C	22,1°C	ok	<i>[Signature]</i>
14:00 19/4/17		25,0°C	44,0%	11,8°C	24,1°C	ok	<i>[Signature]</i>
17:00							
09:00 20/4/17		20,8°C	51,6%	10,5°C	19,9°C	ok	<i>[Signature]</i>
11:00 20/4/17		21,9°C	49,7%	10,9°C	20,8°C	ok	<i>[Signature]</i>
14:00 20/4/17		23,6°C	45,1%	10,9°C	22,5°C	ok	<i>[Signature]</i>
17:00							

• **Daily log**

Daily log is a document which contains information about the requirements and conditions necessary for painting. Daily log will contain information about the degree of cleanliness of the material, rust grade, relative humidity, air temperature, metal temperature etc.

Client: <b>Hydra Ltd.</b>		Order no.:				
Purchase Order: <b>123-4682</b>		Drawing no.: <b>Risers 03162/2</b>				
Procedure ref.: <b>SP/M 2376</b>		Item: <b>6 risers</b>				
Contractor: <b>Blast &amp; Paint Ltd.</b>						
<b>Surface Preparation</b>						
Method of cleaning: <b>Solvent washing</b>		Date: <b>17/3</b>	Time: <b>23<sup>15</sup></b>	Air temp.: <b>17</b>	Steel temp.: <b>16</b>	Dew point: <b>16</b>
Weld spatter etc. removed: <b>OK</b>		Edges rounded: <b>OK</b>	Profile height a. t. ISO 8503-1: <b>Grade Medium (G)</b>			
Abrasive: <b>Cast iron grit</b>		Grading: <b>0.4-1.4</b>	Blast cleaned a. t. ISO 8501-1 to: <b>B Sa 2 1/2</b>			
<b>Painting</b>						
Cost no.:	1	2	3	4	5	Inspected by:
Batch no.:	<b>G-0316-2</b>	<b>G-0216-3</b>	<b>G-0316-2</b>	<b>EG-7143-1</b>	<b>EG-6143-1</b>	
Colour:	<b>black</b>	<b>brown</b>	<b>black</b>	<b>white</b>	<b>yellow</b>	
Prod. name:	<b>Cottaguard</b>	<b>Cottag. 18</b>	<b>Cottaguard 18</b>	<b>Eponuard 18</b>	<b>Eponuard TC</b>	
Method of application:	<b>Airless</b>	<b>Airless</b>	<b>Airless</b>	<b>Airless</b>	<b>Airless</b>	
Required dry film thickness:	<b>50</b>	<b>140</b>	<b>140</b>	<b>100</b>	<b>50</b>	
Start date / time:	<b>18/3 10<sup>00</sup></b>	<b>19/3 10<sup>00</sup></b>	<b>24/3 10<sup>00</sup></b>	<b>30/3 20<sup>00</sup></b>	<b>4/4 9<sup>30</sup></b>	<b>P. Olsen</b>
Finished date / time:	<b>18/3 13<sup>00</sup></b>	<b>19/3 13<sup>00</sup></b>	<b>24/3 15<sup>00</sup></b>	<b>30/3 24<sup>00</sup></b>	<b>4/4 12<sup>30</sup></b>	<b>P. Olsen</b>
Relative humidity: %	<b>50</b>	<b>55</b>	<b>55</b>	<b>55</b>	<b>50</b>	
Air temp.: °C	<b>23</b>	<b>23</b>	<b>23</b>	<b>23</b>	<b>23</b>	
Steel temp.:						

Figure 73: Copy of a daily log report (Dag Kjærsmo, 2003)

- **Progress report**

Progress report can be considered as a weekly report that contain information about problems and corrections carried out during surface preparation and painting.

- **Non-conformity report**

Sometimes during production or painting some problems may arise for example: sometimes the paint may not be cured within 24 hours or sometimes the paint may be applied too thick at some áreas, sometimes in production wrong part would have been fit instead of the actual one etc. Now it will be necessary to take coorrective actions and fix the issues as soon as possible. The problems may be big or small but its the duty of the production manager or paint inspector or quality manager to act immediately for the actions to be taken and correct the errors. After the corrective actions are taken a document is created stating all the problems of non conformity and explaining all the necessary points for the correct action to be taken. Hence, non conformity is a report containing all the errors and the nature of problems that has occurred during production and painting.

## 6.10. Inspection

Inspection is an integral part of quality control and quality assurance. Its purpose is to serve the specifications of painting and match the requirements with painting standards. Inspection helps in checking all work operations from the quality of the steel to the finished product. Inspection document provides all the necessary information regarding the condition of the substrate, assessment of the rust grade of steel, assessment to the cleanliness of steel, control of the paint film thickness, climatic conditions before and during applications of paints. Some of the necessary methods related to inspection have been explained below-

- **Inspection of the substrate**

Inspection is done to the metal to check whether the metal has been damaged, whether there are spatters of welding, to inspect whether the welding does not contain any failures etc. It is recommended that these damages must be repaired before the treatment of metal. If there are sharp edges, it would be particularly important to round off the edges for the paint to be applied uniformly. If welding work has been carried out, all the spatters, undercuts must be removed and any rough or uneven welds must be grinded. All these inspections have to be carried out before the object is sent for surface preparation or painting. All these aspects will be documented and submitted to the surface treatment inspector to carry out further duties.

- **Inspection of rust grades of steel**

When the steel is processed in a furnace, it reacts with air. A layer is formed on surface of the steel and is called mill scale. When the steel is exposed to outer atmosphere mill scale breaks and rust starts forming on the surface. Mill scale and rust creates problems and has to be removed by surface preparation, if they are let to corrode the damage the property of the steel making it useless for future work. Steel structure companies prepare the surface of the steel before it is used for construction. Later, the steel will be surface treated so that no corrosion occurs to the surface in the near future. Rusts are categorized into four grades according to the standard ISO 8501 (Dag Kjernsmo, 2003).

- a. Rust grade A: Steel surface covered with adherent mill scale but little if any rust.
- b. Rust grade B: Steel surface which has begun to rust and from which mill scale has begun to flake.
- c. Rust grade C: Steel surface on which the mill scale has rusted away or from which it be scraped, but with single pitting visible from normal vision.
- d. Rust grade D: Steel surface on which the mill scale has rusted away and on which general pitting is visible under normal vision.

The rust grade of the steel will be noted prior to surface preparation of steel. If the rust belongs to the class C or D then the steel will be rejected because the damage caused to the steel is very critical.

- **Assessment to the cleanliness of steel**

The surface of steel should be clean from corrosion, welding spatters, oil and grease etc. The surface of the steel can be prepared using three grades and each grade designated with appropriate letters such as ``Sa``, ``St`` and ``F1``. Letter ``Sa`` denotes Sand

blasting, ``St`` denotes Hand and power tool cleaning and ``F1`` denotes Flame cleaning.

**a. Blast cleaning, Sa**

Blast cleaning uses abrasive particles that are bombarded by centrifugal action of the turbine to shot the abrasive components over the component. Blast cleaning is categorized into four levels they are: Sa1, Sa2, Sa2<sup>1/2</sup> and Sa3.

i. Sa1: Light blast cleaning

When viewed without magnification the surface should be free from visible oil, grease, dirt, poorly adhering mill scale, rust etc

ii. Sa2: Thorough blast cleaning

When viewed without magnification surface should be free from visible oil, grease and dirt, poorly adhering mill scale, rust, contaminants etc. Any residual contamination shall be firmly adhering.

iii. Sa2<sup>1/2</sup>: Very thorough blast cleaning

When viewed without magnification surface should be free from visible oil, grease and dirt, poorly adhering mill scale, rust, contaminants etc. Any remaining traces of contaminants shall show only as light stains in the form of spots or stripes (Dag Kjernsmo, 2003).

iv. Sa3: Blast cleaning to visually clean steel

When viewed without magnification surface should be free from visible oil, grease and dirt, poorly adhering mill scale, rust, contaminants etc. It shall have uniform metallic colour (Dag Kjernsmo, 2003).

**b. Hand and power tool cleaning, St**

Hand and power tool cleaning will include wire brushing, machine brushing and grinding. Hand and power tool cleaning are classified into two grades St2 and St3. St1 is not included because the cleaning is very light and the surface will not be suitable for painting.

i. St1: Thorough hand and power tool cleaning

When viewed without magnification, the surface should be free from oil, grease and dirt, poorly adhering mill scale, rust, paint coatings etc.

ii. St2: Very thorough hand and power tool cleaning

According to this grade the surface shall be treated much more thoroughly to give a metallic sheen arising from the metallic substrate (Dag Kjernsmo, 2003).

**c. Flame Cleaning, F1**

Flame cleaning is a process of cleaning steel metal substrates by high intensity oxyacetalene flame. Before flame cleaning thick rusts should to be removed by chipping and the surfaces should be cleaned by power tool wire brushing. Flame cleaning is indicated by letter F1.

- i. F1: When viewed without magnification, the surface shall be free from mill scale, rust, paint coatings and foreign matter. Any remaining residues shall show only as a discoloration of the surface (Dag Kjernsmo, 2003).

- **Control of the paint film thickness**

Before the application of paint coatings surfaces should be free from mill scales, welding spatters, oil, grease and foreign residues. Hence, strict quality control of the work has to be carried out. Quality control assessments have to be documented on a daily basis in order to eliminate major or minor damage/repairs. Paint film will be applied according to the measurements specified in the technical data sheet for painting. There are some equipments to measure the wet and dry film thickness. And paint film thickness can be controlled by using these equipments. Usually wet film and dry film thickness will be measured and the instruments used to measure these thicknesses are also discussed.

- i. **Wet paint film thickness**

Wet paint film thickness is used to determine whether the paint thickness has been applied correctly. The wet film thickness will be measured immediately after the paint is applied. Comb gauge and Wheel gauge are popular instruments that are used to measure wet film thickness.

- a. **Comb gauge**

Comb gauge is an instrument to measure wet film thickness, the outer teeth are called base line and in between there exist teeth with different range of heights i.e. the height of the teeth progressively decrease from the base line. Each tooth has a specific thickness.

After the paint coat is applied, the comb gauge is placed on the coat on its base line and the gauge is removed from the surface and the teeth are examined to determine which is the shortest tooth that touches the wet film. The film thickness lying between the last

wetted tooth and the first non-wetted tooth is recorded. Suppose if all the teeth are wet then another scale or gauge has to be used.

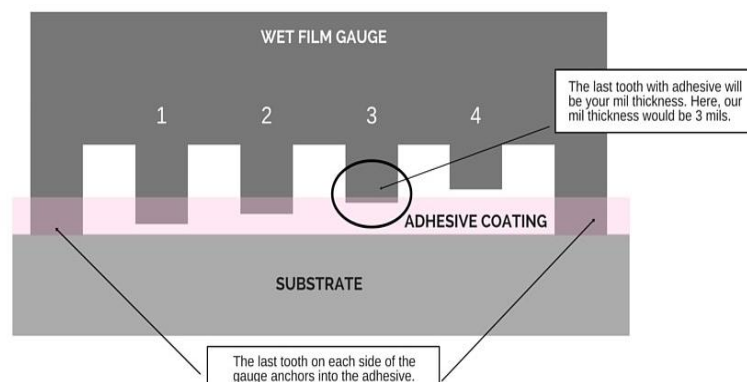

**Figure 74: Wet film thickness measuring gauge (Using a Wet Film thickness gauge)**

### **b. Wheel guage**

Wheel guage is another instrument used to measure wet film thickness; the wheel guage consists of three equally spaced rims with the central rim having smaller diameter and eccentricity. The Wheel guage has a grip at the centre. When the wheel is rolled over the paint surface the central Wheel having eccentricity shows where it just touches the wet paint surface, the thickness of the film can be read on the calibrated scale engraved on the outer wheel.

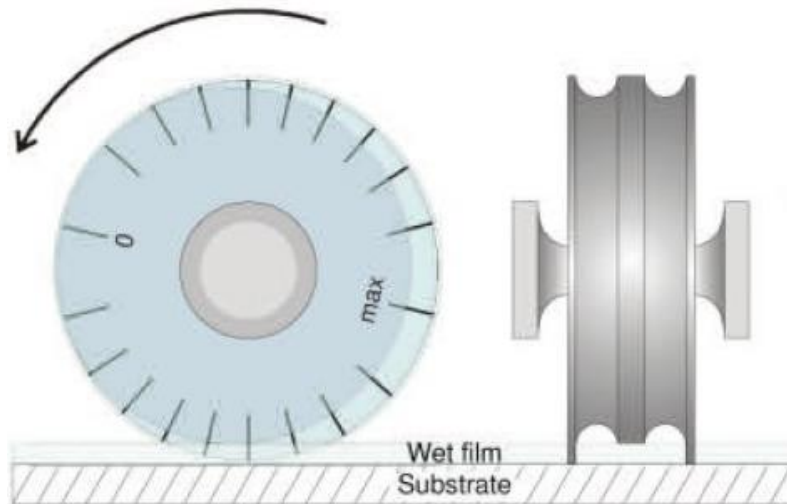

**Figure 75: Wheel guage to measure wet film thickness (Using a Wet Film thickness guage)**

### **ii. Dry film thickness**

Measuring of dry film thickness is carried out after the paint is cured. There is variety of instruments available in the market to measure dry film thickness of paint but these instruments may slightly vary with their working principles.

#### **a. Magnetic induction instrument**

This instrument uses a probe that is placed on the paint substrate to measure the thickness of the paint. Magnetic induction instrument works on the principle where a low frequency voltage in the probe creates magnetic field between the probe and the substrate. Since, the paint or coat is not magnetic; the resistance in the magnetic circuit is directly proportional to the thickness. And the signal from the probe is converted to thickness and is shown digitally in the instrument.

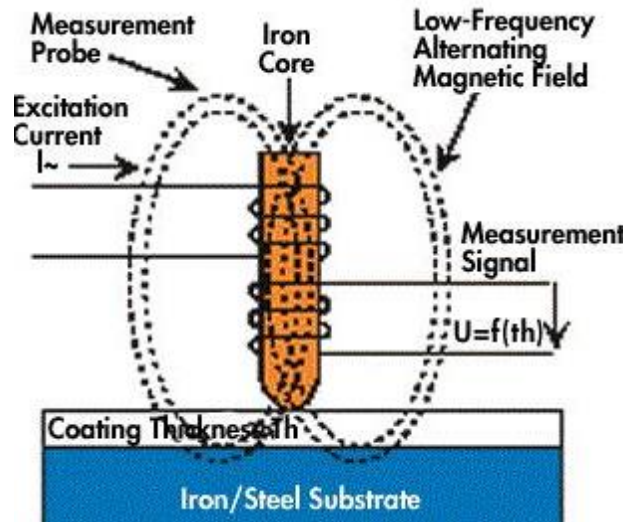

Figure 76: Magnetic induction instrument (Magnetic Induction Process)

### b. Magnetic pull-off instrument

Magnetic pull of gauges will have a permanent magnet in the front, calibrated spring and a graduated scale. Dry film thickness is measured by the magnetic attraction between the magnet present in the gauge and the magnetic steel substrate. The paint separates the magnetic force of attraction between the magnetic gauge and the magnetic steel substrate, so it is easy to slide the magnet over the steel substrate. So, there is stronger magnetic attraction for thin film coatings and lesser attraction for thick film coatings. The coating thickness is measured by the pull of force.



Figure 77: Magnetic pull off instrument for measuring dry film thickness (Magnetic Induction Process)

### • Climatic conditions

Climatic condition plays a major role in paint applications. During surface preparation or during application of paints, it is very important to work under ambient temperatures. If the climatic conditions are unfavourable, if the relative humidity is high then condensation of the steel takes place. If the surface of the steel is blast cleaned at this condition, then the steel will flash rust and also at these conditions if paints are applied then adhesion problems occur. Due to these factors climatic conditions are checked before or during the application of paint. Daily log records are maintained to keep in

track of the air temperatures, material surface temperature, relative humidity, dew point etc.

### **6.11. Overview of the chapter**

The choice of selecting paints according to the standards will have significant effect on protecting paint from corrosion because painting standards clearly gives an overview of the technologies of paint, selection of paint according to the type of environment etc. Corrosivity is a major problem that every metallic construction companies will have. They take different measures to get rid of corrosion. Huge sums are spent to protect steel from corrosion. In this report, a study has been made on corrosion and its prevention and a small explanation has been made on paint coats, paint failures and inspection of paints before and during the application of paints.

Corrosion can only be stopped by applying anti corrosive elements that acts a barrier between the corrosive environment and the metal, further research is going on to eliminate corrosion but to eliminate corrosion completely is not an easy task because corrosion occurs by the grace of nature. However, to protect steel from corrosion the adoption of paint system has been successful. There are varieties of paints available in the market that serves for different corrosion protection. To this date, paint coating systems have performed well. The field evidence and previous records have explained how well the paint coating systems have worked to protect steel from corrosion, with small maintenance repairs. Therefore, paint coating systems remains as one of the choice to work as protective systems against corrosion.

## 7. Department of Commercial

### 7.1. Commercial Management

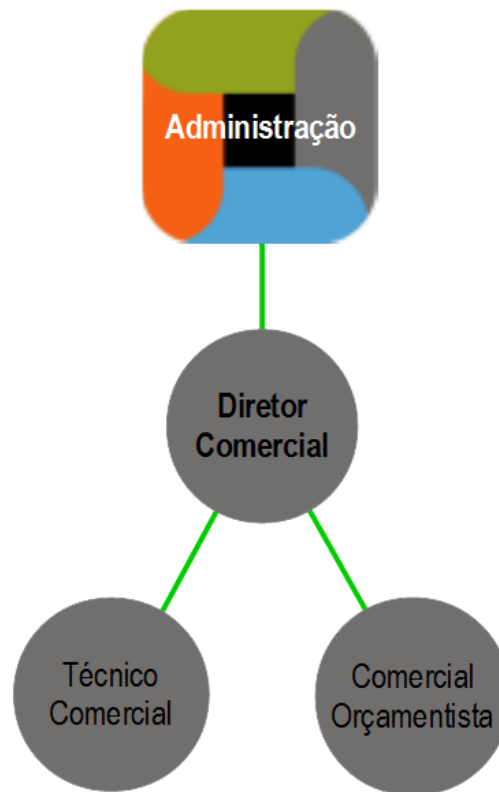
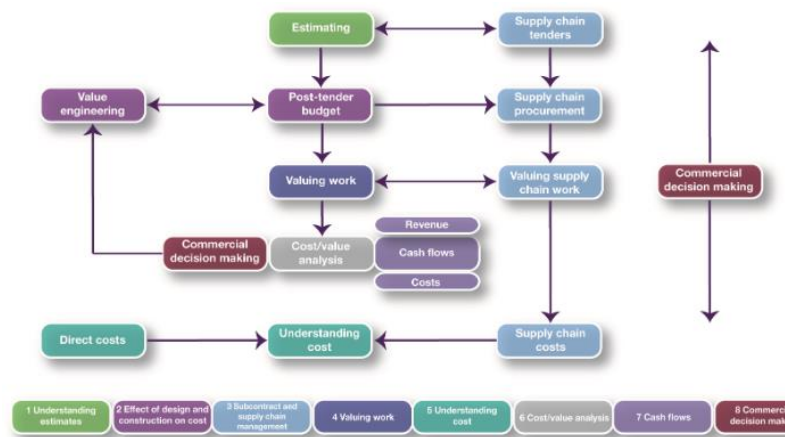

**Figure 78: Structural Organization of Commercial department in Electrofer Grupo** (Organograma of Commercial department)

Commercial department in an organization is technically a business discipline. Commercial department is involved in the identification of business opportunities. This department is also in-charge of revenue and expenses to generate financial returns. Those who work in the department of commercial have many responsibilities and the responsibilities may vary for each individual or it may be the same for every individual. Some of the basic duties of the commercial management of an organization are listed below-

- i. Contract formulation
- ii. Risk management
- iii. Contract negotiation
- iv. bidding
- v. Identify business opportunities
- vi. Monitor costs
- vii. Guiding Project management in financial aspects
- viii. Providing instructions to the Project management team, to ensure that they understand the importance of the projects
- ix. Resolving commercial problems
- x. Monitor performance of the Project by comparing it with other projects

The figure below describes the activities of the commercial management-



**Figure 79: Activities of commercial management** (Commercial management of construction, 1st edition, guidance note, 2016)

## 7.2. Commercial Relationships

An American business magnate once said that, ``Business is not just doing deals; business is having great products, doing great engineering and providing tremendous service to customers. Finally, business is a cobweb of human relationships``. Business world is full of relationships, a well maintained relationship in business will have continuity of success with the same customer and thereby good understanding, good relationship and trust with the customer will last longer. Relationships in business may be very complex and may also reside various variables. There is no document or standard that explains about the various complex variables in business relationships, business relationships are built only with the depth of trust and confidence that a buyer get from the seller. There are three types of buyer seller relationships and each relationship portrays different classes of activities and responsibilities. The three types of buyer seller relationships are

- i. Transactional Relationships
- ii. Collaborative Relationships
- iii. Supply Alliance Relationships

- **Transactional Relationships**

Transactional relationship is a very common and most basic type of relationship. In this type of relationship neither of the party is concerned with the well being of others, it is just expressed as arm length relationship. This relationship is neither good nor bad, the relationship is just considered with the series of independent deals. Costs, data or forecast is not shared just because both the parties are not concerned with others well beings. In this relationship, getting good price is the focus of the transactional relationships. Price is the main focus of this relationship. Since, neither of the party will rush in support of each other assistance when the other party is in trouble or at bad times. The price is based on the forces of the market supply. Hence, the price can be established with the purchasing time and energy.

- **Collaborative Relationships**

In collaborative relationships, cooperation, trust and interdependency will be the key aspect. The parties depend on each other since, the Money flows in their supply chain or their supply network. This relationship works with the collaboration of trust, communications, joint efforts and fostering interdependency. If the parties work with collaboration of cooperation and interdependency then there will be continuous improvement in the process which leads tototal reduction costs, high quality and reduced time for manufacturing. In this relationship, the other parties involve in supporting the other party when problems arise or at bad times. The major disadvantage of this type of relationship will be the investment for human resources, time and energy that are required to manage the relationships.

- **Supply Alliance Relationship**

The main difference between collaborative relationship and supply alliance relationship will be the intitutional trust. Supply allaince builds incredible benefits with physical asset specalization and human specalization. Physical asset relationship refers to the relationship with the specific capital investments for machinery, tools, research, delivery process etc. Human specalization refers to the relationship between the parties on how the parties are accumulated with the long standing relationships. The primary benefits of supply allaince relationship will be lower total cost, reduced delivery time to market, continuous imporvement in the quality of the product, imporved technology for manufacturing. The main focus of this type of relationship will be the continuous improvement of the process without squeezing out the cost.

The figure below portrays the characteristics of the above mentioned principle types of relationships-

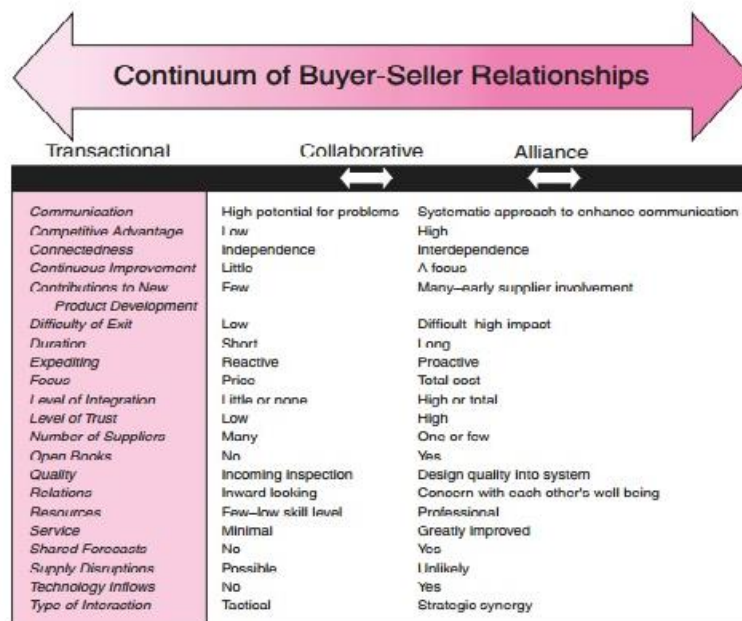

Figure 80: Characteristics of buyer seller relationships (htt2)

### 7.3. Role of budgeting in Managements planning

A budget is defined as management’s quantitative expression of plans for a forthcoming period or it is estimation of income and expenditure for a set period of time. Budgeting helps organization to focus on targets to be achieved. Master budget helps in understanding the overall financial plan for certain period of time, it includes overall budget of companies operation and sales. Master budget comprise of operational budget and financial budget. Operational budget reflects company’s sales and companies operating costs whereas financial budget shows companies financial aspects such as cash flow in sales and expenditures. While forming master budget all the detailed expenses of budgets are taken from each department of an organization. The main aim of master budget is the profitable plan and the income statements are budgeted on monthly basis. The figure below is the flowchart of budget preparation-

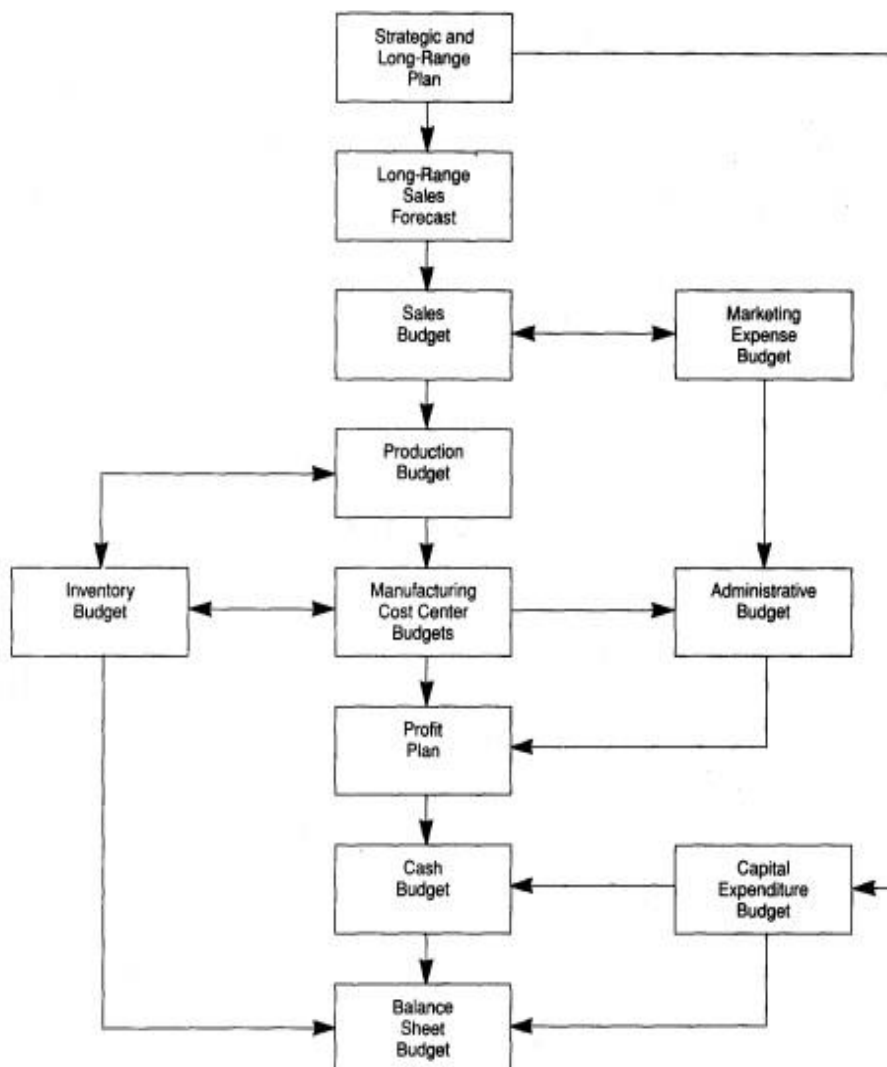

Figure 81: Budget preparation flow chart (OWNER'S ROLE AND RESPONSIBILITIES IN THE COMMISSIONING PROCESS, 2016)

## 7.4. Understanding cash flow

Cash flow in simple terms can be defined as the net amount of cash flowing into and out of business. If the flow of cash is higher it means that the liquid assets of the company are increasing. If the cash flow is reduced then the liquid assets of the company are decreasing. Cash flow is just used to determine the health of the company i.e. to assess the quality of income that a company can have. This determines whether the company is in a position to remain solvent. Cash flow statement is a financial statement that contains all the listings of the cash flow in and out of the business. Cash flow statement is a financial document that contains all the listings of the cash flow that occurred during past transactions of a business. Cash flow budget is the financial document that projects the flow of cash for future business transactions. To make a financial document of cash flow for business transactions net working capital is very important. If the net working capital is sufficient, then cash flow analysis will not be critical but if the net working capital is insufficient the cash flow financial document may show liquidity problems that may occur during the forthcoming period. Cash flow budgets are constructed to project the actual inflows and outflows as the organization progresses through the year. Hence, cash flow can be adjusted to the projections for the forthcoming period.

<b>Cash Inflow</b>	<b>First Q</b>	<b>Second Q</b>	<b>Third Q</b>	<b>Fourth Q</b>
Beginning Cash Balance	\$5,000			
Sale of Crop Products		\$50,000		
Sale of Livestock Products	\$25,000			
Government Payments				\$10,000
<b>Total Inflow</b>	<b>\$30,000</b>	<b>\$50,000</b>		<b>\$10,000</b>
<b>Cash Expenditures</b>				
Seed	\$10,000			
Fertilizer		\$20,000		
Feed	\$10,000			
Processing			\$10,000	
Marketing				\$5,000
Capital Purchases		\$10,000		
Interest			\$5,000	
Debt Payments			\$10,000	
<b>Total Expenditures</b>	<b>\$20,000</b>	<b>\$30,000</b>	<b>\$25,000</b>	<b>\$5,000</b>
<b>Quarterly Net Cash Flow</b>	<b>\$10,000</b>	<b>\$20,000</b>	<b>-\$25,000</b>	<b>\$5,000</b>
<b>Cumulative Net Cash Flow</b>	<b>\$10,000</b>	<b>\$30,000</b>	<b>\$5,000</b>	<b>\$10,000</b>

**Figure 82: Cash flow budget analysis (quarterly)** (Iowa State University Extension and Outreach)

Cash flow budgeting is very important for any organization because it provides a clear vision to project funds and sources for the upcoming period. Technically speaking, for a machine to function smoothly grease is the main ingredient similarly for business transactions cash is very important. Cash flow budgeting will provide clear vision about when to borrow money, the amount of cash need to be borrowed or suppose the liquid assets are more then the flow of cash for forthcoming period can be evaluated.

## 7.5. Estimation in Construction Industry

Estimation is the process of establishing the cost of carrying out construction works. Estimation of the cost of the project will start immediately after receiving tender documents. Estimating the cost of project is often time consuming and is tedious. Estimator is the one who performs all the activities of estimation process after receiving the bill of quantities (BOQ), specifications of the project and contractual drawings. After the estimator has defined the actual price of the project the authority of the management is the one who decide on the final price of the project. The management authorities will also note that the estimation will not be overpriced or underpriced. It would be better to know cost estimation from the customer's perspective because it would become easy to know expected cost of the project for allocation of the budget. But the contracting companies try to undertake the cost estimation for tendering purpose in order to obtain good profit margins of the project.

Cost Estimate							Page 2
	Description	Qty	Price	UM	Draw	Me	Total
51	<b>SITE PREPARATION</b>						
52	• Rough Stake	1	125.00	Lump Sum	0.00	125.00	125.00
53	• Clearing, Grading, Hauling	6	115.00	Hour	0.00	690.00	690.00
54	• Fill Dirt	5	75.00	Load	375.00		375.00
55	• Locate Corners	1	275.00	Lump Sum	275.00		275.00
56					0.00		0.00
57	<b>TOTAL SITE PREP (LINES 52-55)</b>				650.00	815.00	1,465.00
58	<b>FOOTINGS</b>						
59	<b>FOOTINGS</b>						
60	• Layout, Dig, and Pour	225	1.10	LF	247.50		247.50
61	• Steel	45	5.40	EA	243.00		243.00
62	• Concrete	15	115.00	CY	1,725.00		1,725.00
63	• Drains				0.00		0.00
64	<b>TOTAL FOOTINGS (LINES 60-63)</b>				2,215.50	0.00	2,215.50
65	<b>FOUNDATIONS</b>						
66	<b>FOUNDATIONS</b>						
67	• Concrete	20	115.00	CY	2,300.00		2,300.00
68	• Brick				0.00		0.00
69	• Block				0.00		0.00
70	• Mortar				0.00		0.00
71	• Sand	5	85.00	CY	425.00		425.00
72	• Steel	75	5.40	EA	405.00		405.00
73	• Vents				0.00		0.00
74	• Damp Proofing	1	375.00	Lump Sum	375.00		375.00
75	• Backfill				0.00		0.00
76	• Labor	1	1,000.00	Lump Sum	0.00	1,000.00	1,000.00
77	• Foundation Survey	1	475.00	Lump Sum	475.00		475.00
78					0.00		0.00
79	<b>TOTAL FOUNDATIONS (LINES 67-77)</b>				3,980.00	1,000.00	4,980.00
80							
81	<b>PAGE TOTALS (LINES 57, 64, 79)</b>				6,845.50	1,815.00	8,660.50
82							
83							
84							

Figure 83: Sample cost estimation for site, footings and foundations (Frederick S. Merritt, 1996)

## 8. Department of Construction Project Management

### 8.1. Construction Management (CM)

Construction Project Management is the "The art of directing and coordinating human and material resources throughout the life of a project by using modern management techniques to achieve predetermined objectives of scope, quality, time, cost and participants satisfaction (Simpkin, 1976)".

- Project Management Institute

### 8.2. Construction Management chart

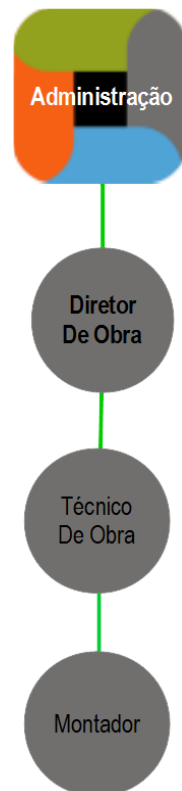

Figure 84: Construction Management organizational structure (Electrofer Group internal document.)

### 8.3. Mission of Construction Management department in Electrofer

Win Works, so, that the company stays in existence and thrives.

### 8.4. Objectives of the department

In a Construction industry, the Construction Project Executive will have various objectives, the construction executive objectives of electrofer are mentioned below-

- Ensuring high customer satisfaction
- Planning the project to have the best possible result in terms and budget
- Making decisions, finding solutions, and to take initiatives, so that proper planning is accomplished
- Constantly updated on all the matters relating to work
- To ensure good definition and compliance with quality requirements

- To serve as a bridge between customers and the internal structure
- Anticipate and prevent contingencies during construction
- Perform mounts without accidents
- Track subcontracts relating to work
- Issue records and authorize / check invoices
- Track and analyze cost control

### **8.5. Assessment plan**

The Construction Managers always take necessary preparatory steps to produce the required output on time smoothly. The Managers schedule a plan that specifies-

- What procedures to be adopted to complete the assessment process?
- How, when and by whom will the process be done?
- What resources are required and from where these resources will be obtained?

The assessment plan that the construction manager makes must clearly specify how the activities of the process will be completed and must also specify assigned responsibilities for everything that needs to be done.

Sometimes, the assessment cannot be completed in given time, with the human and resource available. In this situation, the problems must be discussed with the collaborating parties whether the timeframe can be extended or there must be cut back on some aspects.

The figure below is the possible schedule for planning and implementing assessments for a three week period.

Activity	Time (days)																				
	Week 1							Week 2							Week 3						
	1	2	3	4	5	6	7	8	9	10	11	12	13	14	15	16	17	18	19	20	21
1. Establish/re-confirm working arrangements with partners																					
2. Compile and review secondary data																					
3. Review working scenario from initial investigation																					
4. Define assessment objectives & timeframe																					
5. Draw up assessment plan																					
6. Define information requirements																					
Decide data collection methods and sampling procedure																					
7. Design/customize data collection instruments																					
Pre-test assessment tools (with team training)																					
Finalize assessment tools																					
8. Prepare briefing kit, supplies & equipment																					
9. Identify and recruit team members																					
Orient/train team(s)																					
10. Arrange transport, security and communications																					
11. Collect data at field sites																					
12. Process and analyse data																					
13. Identify and analyse response options																					
14. Report writing																					
15. Present findings																					
Finalize and disseminate the report																					

Figure 85: Sample schedule for an assessment plan (Understanding and Monitoring the Cost-Determining Factors of Infrastructure Projects)

Basically, after the commercial manager gets the projects to the companies, the Construction Managers will take up the activities of the project. The project manager will plot the time schedule for the project from the initial stage of the project until it reaches the customer. The time schedules will be for -

- Time for designing and planning
- Time for training individuals
- Time for field data collection
- Time for processing the collected date and analyzing them

The flowchart for steps involved in collecting data, choosing methods and planning for data processing and analysis for a project.

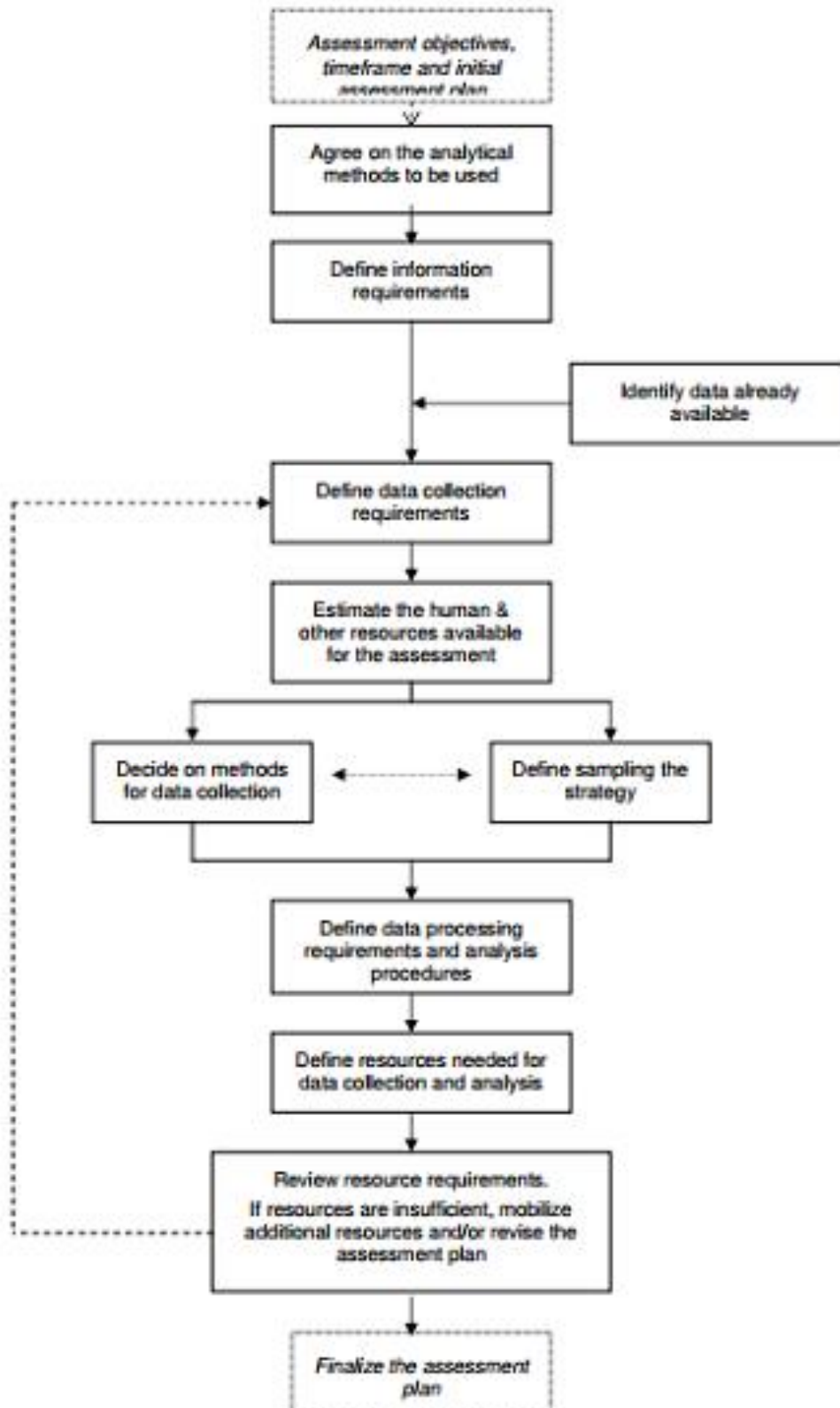

Figure 86: Steps involved in collecting data, choosing methods and planning for data processing and analysis (Understanding and Monitoring the Cost-Determining Factors of Infrastructure Projects)

## **8.6. Development of a Project by Project Manager**

The basic aim of a Project Manager will be to implement an economically beneficial objective by considering the terms of technical performance, timescale and budget. Project Managers usually follows a set of hierarchy which comprises a series of stages.

- **Project feasibility:**

When the Project Managers receive projects, the Manager frames a chart defining what the customer requirement is and how the requirement can be satisfied to the customer. After framing the chart the Manager and the client decide upon the size of the project and quality that is required in the project. Complete details of the project will be discussed and evaluated for cost estimates and expected operational performance.

- **Design of the project**

After all the discussions for the requirements of the project, work will start to develop plans for the project. In the beginning, outline of the project will be drafted which includes all the major aspects of the project. This outline design gives an idea for the detailed design and to estimate the overall cost of the project. Project Managers will discuss with the design team to explain the importance of the project and how the detailings are to be given.

- **Finance**

Finance is a basic necessity to develop any project. The structure of the finance flow will be depending on the nature of the project.

- **Construction of the project**

Construction will be the actual construction of the project. The construction of the project will be according to the design produced. Contractors who legally take up the projects will initiate the project under various contractual agreements. The construction of the project will be depending on the degree of information available in the design documents that are prepared.

- **Project handover**

Constructional project managers calculate the time schedules for the projects. The project will be handed over to the customer basically on time but sometimes it may get delayed due to some reasons. For the delayed project submissions, the projects may include financial penalties. Percentage of the overall cost of the project may also be reducing if the client does not receive the project as specified.

The figure below is the flowchart for the development of the projects at various stages-

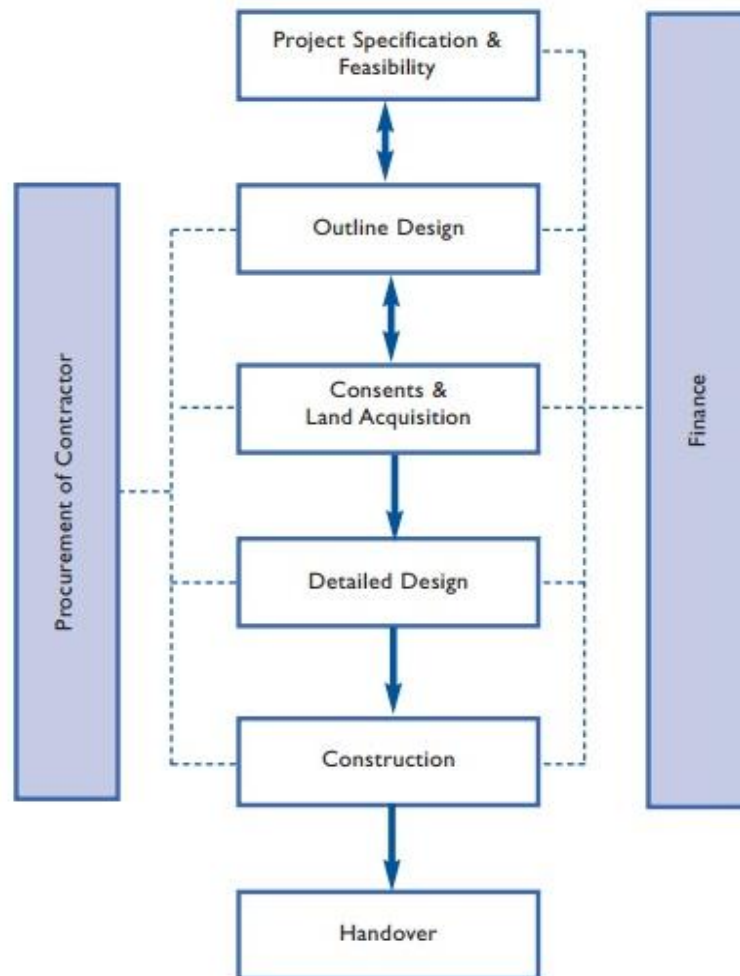

**Figure 87: Flowchart for the development of a project** (Understanding and Monitoring the Cost-Determining Factors of Infrastructure Projects)

### 8.7. Budgeting for the assessment

Construction executives make sure that they have realistic budget before the start of any project. The construction manager first focuses on the factors that determine the initial cost of the project and the factors that vary the cost of the projects.

Basically no two construction projects will cost the same amount of money, however similar they are. There are many barriers that affect the cost of construction due to the variation of economic factors and other conditions such as cost of labour in that region where the project is being procured, variation in the price of the land and materials. When the construction managers summarises the project cost, he also considers number of factors that are explained below-

➤ **The project specification**

The project specifications usually define the physical attributes. While erecting a structure the attributes like the overall total space used by the structures in that particular space, the materials used for erecting (such as nuts, bolts, weld materials etc), the amount of steel required etc.

➤ **Location**

This is one of the factors that the construction manager has to look upon, since; he has to enquire the actual cost for construction, materials, design etc. Since, these standards vary widely across the world because of the varying distance from the suppliers, weather conditions, and general market conditions.

➤ **Form of procurement / contract**

The procurement or contract form used by the project dealer can alter the estimated cost of the project.

➤ **Site characteristics**

To verify site characteristics soil surveying must be undertaken because the soil may be affected by poor ground conditions. Due to this actual cost estimation cannot be done.

➤ **Tax liabilities**

The project manager has to consider the tax liabilities. During cost estimation, the manager has to sincerely look after to tax liabilities because the organization will be liable to pay taxes on all its purchases.

➤ **Timescale**

Timescale depends on the actual size of the project. If the project is big then it takes longer time to produce and the project costs will be higher. Hence, the construction manager will examine the time that will be implemented on the project.

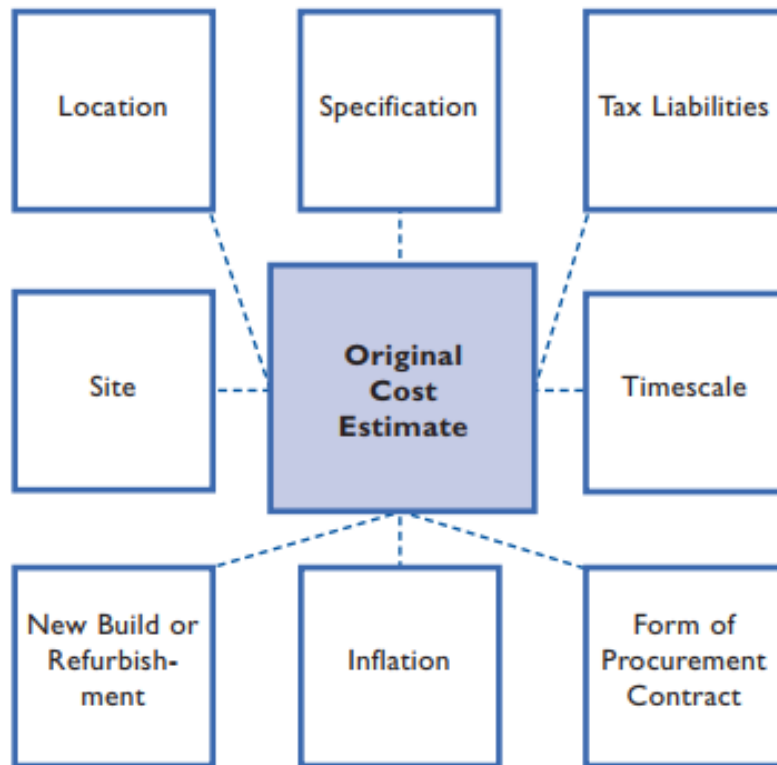

**Figure 88: Factors affecting initial cost of the project** (Understanding and Monitoring the Cost-Determining Factors of Infrastructure Projects)

The construction budget will be made considering various factors (i. e. considering the cost of raw materials, financing cost, administrative cost, labour cost etc). The construction project anagers considers all these factors and make all the calculations using a spreadsheet. The figure shown below is an example of construction budget.

CONSTRUCTION BUDGET												
										BUDGET	ACTUAL	UNDER/OVER
										\$13,600.00	\$12,800.00	\$800.00
		LABOR	MATERIALS		\$/UNIT	FIXED COST	BUDGET	ACTUAL	UNDER/OVER			
TASK	VENDOR SUBCONTRACTOR/CONTRACTOR	HRS	RATE	UNITS	\$/UNIT							
<b>GENERAL REQUIREMENTS</b>												
Plans & Specifications		10	\$15.00	60	\$10.00	\$200.00	\$850.00	\$800.00		-\$50.00		
Plan Review							\$0.00			\$0.00		
Permits, Zoning, Building, Environmental, Other							\$0.00			\$0.00		
Survey							\$0.00			\$0.00		
Impact Fee							\$0.00			\$0.00		
Administrative Costs							\$0.00			\$0.00		
Financing Costs							\$0.00			\$0.00		
Legal Fees							\$0.00			\$0.00		
Engineering Fees							\$0.00			\$0.00		
Other							\$0.00			\$0.00		
							\$850.00	\$800.00				
<b>SITE PREP</b>												
Demolition (Remodel)							\$0.00			\$0.00		
Jacking & Shoring (Remodel)							\$0.00			\$0.00		
Dust control, Surface Protection							\$0.00			\$0.00		
Job-Site Access							\$0.00			\$0.00		
Job-Site Security							\$0.00			\$0.00		

Figure 89: Construction budget (Electrofer Group internal document.)

### 8.8. Project Execution

Execution of the Project construction is a challenging activity. It requires lots of efforts and involves the right choice of technology, the estimation of resources and the time required for individual tasks, definition of the work etc. Project managers plan the project as the generation of the required activities and analysis of the implications of these activities. In order to execute a project the project Manager adopts a primary emphasis on cost control or schedule control. A planning is made to schedule the construction activities as per customer preference. The project will be executed with proper estimations of cost schedule or time schedule.

## 9. Conclusion

The curriculum internship was like a bridge between theoretical knowledge and the reality of the work in the field of constructional works. My internship hosting company took the responsibility to teach and shaped me as an Engineer who can take up the work related in the field of construction. My internship hosting company helped me in acquiring different knowledge in different positions.

Since, I took my internship in ELECTROFER GRUPO, a metallic construction company; I got an opportunity to work in the different fields of constructional work which helped me gain knowledge by seeing what exactly they work in their respective departments and what their main responsibilities are. By this, I was able to acquire high level of confidence to compete with the problems that arise in the area of metallic constructional works.

Working with the Engineers of my internship hosting company has not only thought me to deal with the problems that arise in constructional works. They also thought me the importance of the customer needs, quality of work to be produced and to finish the work in scheduled time.

The aim of this internship was to set a foresight to gain knowledge in various fields of metallic constructional works. Right from the beginning of this internship various methodologies that are involved in the fabrication of metallic structures were learnt.

In this phase of my internship, I have learnt how to research a production of metallic structures by analyzing technical drawings, continuous inspection of the parts produced, by gathering existing plans from the project managers or general production manager.

As I joined Electrofer for intership, my first section was in the department of design. In this department the first thing I learnt before getting to know about the software is to understand the technical drawings later I developed the ability to design with all the necessary information tht existed in the technical drawing as per the customer demands. I got a very good opportunity to design a bridge, a container to support the zinc galvanization wells etc. The most important things I learnt was to give clearances for welds, placement of bolts at their exact positions, use of macros, switching between the views at the same point of time. In this department, I learnt all the aspects to convert a 3D design into 2D drawings that is required for production.

In the next stage of my internship, I got an opportunity to study about the execution of steel structures, qualification of welders, tracibility of the parts, assuring nonconformities, creating and making use of Inspection and Test plan. In this deparment I was encouraged and given with responsibilities to control the production as per quality requirements and following the statements of Inspection and test paln. In the later stages, I was also given an opportunity to maintain the quality works on Lisbon Bridge. The responsibilities included tracebility of the parts, qualification of welders or welding specimens according to the standard ISO 15614; control the wedling according to the welding procedure specificationsand dimensional control. As per my research

experience in the department of quality, it is very necessary that the execution of steel structures follows the selection criteria based on the complexity of the project.

The department of production was another wonder where I could closely learn the ways of producing steel structures. There was a uniform flow of work right from obtaining raw materials until the parts are completely produced. The beams or plates were cut or bent with the machines that were automatically controlled by the CNCs. I learnt the usage of right type of welding filler welding materials.

After the parts are assembled and fused, the final step is to give them appearance according to the standards of quality. This is done in the department of painting. After the steel structures are produced giving appearance is not only the main factor to be considered because the steel structures get corroded. For this reason painting quality standards are followed. The standards are explained according to the range of corrosion and the type of environment that the structure will be erected. Some of the steel structures will be shot blasted or galvanized. This process will be adopted according to the execution criteria of steel structures. In this department, I learnt lot about corrosion, painting failures and the execution standards of paints.

After completing the training in technical departments, it was time for me to move towards the management side. Now, it was time for me to learn about budgeting and maintaining relationships with customers. I learnt about various type of customer-buyer relationships and the ways that the budgeting will be negotiated and how to satisfy the customers with his demanding needs.

As per the experience gained through the phase of my internship, it was very easy for me to know the importance of Project Manager. The duties that were given to me was very responsible since my duty was to implement the structural design by having continuous contact with the designers. And also I gained strong depth of knowledge, responsibility and foresightness to not to mess up with the project either in terms of selecting the materials, completing the project on time, scheduling the time of work etc.

Overall the internship program laid a strong foundation to start my career. Now I am feeling proud that I have successfully completed my internship program. Now it is the right time for me to contribute towards the works of Quality of construction.

Once again, I would like to thank Electrofer Group and its employees for recognising me and for supporting me to complete my curriculum internship successfully.

## 10. Bibliography

1. Electrofer Group, (2017) .
2. **Structures, Tekla.** *Lesson 1: Basic training.* s.l. : Tekla Structures.
3. **Society, American Welding.** *Structural Welding code - Steel.* 17th. Miami, Florida : American
4. inspection-for-industry.com . *inspection-for-industry.com-- The Best Industrial Inspection Informative Site!* [Online] 2012-2013. <http://www.inspection-for-industry.com/inspection-and-test-plan-for-steel-structure.html>.
5. *www.inspection-for-industry.com.* [Online] <http://www.inspection-for-industry.com/support-files/Inspection-and-Test-Plan-for-Steel-Structure.pdf>.
6. *Execution of steel structures and aluminum structures - Part 2: Technical requirements for steel structures.* Brussels : European committee for standardization, August 2011.
7. Specifying the right execution class. [Online] <http://www.newsteelconstruction.com/wp/specifying-the-right-execution-class/>.
8. **baňské, Sborník vědeckých prací Vysoké školy.** Miroslava ELFMARKOVÁ, Ivo HLAVATÝ\*. [Online] 2008. <http://transactions.fs.vsb.cz/2008-1/07.pdf>.
9. SteelConstruction.info- The free encyclopedia for UK steel construction information. [Online] <http://www.steelconstruction.info/Welding>.
10. Flux cored Arc welding. [Online] Wikipedia. [https://en.wikipedia.org/wiki/Flux-cored\\_arc\\_welding](https://en.wikipedia.org/wiki/Flux-cored_arc_welding).
11. Welding technology or techniques. [Online] May 12, 2016. <http://weldingtechno.blogspot.pt/>.
12. Submerged Arc Welding. *en.wikipedia.org.* [Online] [Cited: DEC 3, 2016.] [https://en.wikipedia.org/wiki/Submerged\\_arc\\_welding](https://en.wikipedia.org/wiki/Submerged_arc_welding).
13. *info@koeco.net.* [Online] Koster&Co. <http://www.koeco-gmbh.com/about-us/>.
14. *Chapter 3: Flux-Shielded Arc Welding.* **Houldcroft, P. T.** Cambridge : Cambridge University Press, 1967. ISBN 0-521-05341-2..
15. welding- Basic steps, terms, application, different welding joint and positions. [Online] <http://www.zoombd24.com/arc-welding/>.
16. *Visual Inspection and Major defects- welding.* Electrofer Grupo, s.l. : s.n.
17. **Mathers, Gene.** Design - Part 1. [Online] <http://www.twi-global.com/technical-knowledge/job-knowledge/design-part-1-090/>.
18. Tools Instruments. [Online] [http://www.hkrok.com/measuring-tools-welding-gauge-c-531\\_544.html](http://www.hkrok.com/measuring-tools-welding-gauge-c-531_544.html).
19. Ultrasonic testing. [Online] December 2009. [https://en.wikipedia.org/wiki/Ultrasonic\\_testing#How\\_it\\_works](https://en.wikipedia.org/wiki/Ultrasonic_testing#How_it_works).
20. *St. Johns group of Institution.* [Online] [http://www.stjohns.org.in/stjohns\\_coursesdes.php?content\\_id=15](http://www.stjohns.org.in/stjohns_coursesdes.php?content_id=15).
21. "GalvInfoNote / The Spangle on Hot-Dip Galvanized Steel Sheet". [https://en.wikipedia.org/wiki/Hot-dip\\_galvanization](https://en.wikipedia.org/wiki/Hot-dip_galvanization). [Online] August 2011.
22. Hot Dipped Wire Galvanizing Line. <http://www.china-anbermachine.com/Wire-Galvanizing-Line/Hot-Dipped-Wire-Galvanizing-Line.htm>. [Online] Wuxi Anber Machine Co., Ltd.
23. **Dag Kjernsmo, Kjell kleven, jan scheie.** *Corrosion protection, inspectors book of reference.* s.l. : Bording A/S, 2003. 87-989694-04.
24. Uniform corrosion on mild steel. [Online] [https://www.gewater.com/images/handbook/cooling\\_water\\_systems/24-2.jpg](https://www.gewater.com/images/handbook/cooling_water_systems/24-2.jpg).
25. Stainless Steel and Corrosion. *Stainless Steel and Corrosion.* [Online] Southern Africa Stainless Steel development association, 2015. <http://sassda.co.za/stainless-steel-and-corrosion/>.

26. Strategies for Combatting Coil Corrosion. [Online] 10 4, 2010.  
<https://www.chem.info/article/2010/04/strategies-combatting-coil-corrosion>.
27. **Sharma, Rishabh.** Environmental Degredation of Materials . [Online]  
<https://www.slideshare.net/RISHABHSHARMA248/presentation-on-erosion-corrosion>.
28. Cathodic Protection Systems and Repairs. [Online]  
<http://www.coastmobileutilities.com/cathodic-protection-systems-and-repairs/>.
29. CAUSES OF PEELING PAINT. [Online] Krystal Companies, LLC., 2017.  
<http://www.krystalklean.com/causes-of-peeling-paint/>.
30. Scott's Painting & Staining Inc. [Online] <http://www.scottspainting.com/tips.htm> .
31. Davi PAints. [Online] 2009. <http://www.davispaint.com/DavisPaintProblemSolver.aspx>.
32. Hot Rod. [Online] The Enthusiast Network, 1993. <http://www.hotrod.com/articles/0901sr-help-with-troubleshooting-paint-problems/>.
33. Acrylatex Coatings & Recycling, Inc. . [Online] I.T.S, 2011.  
<http://www.acrylatex.com/content/why-does-paint-crack-and-peel>.
34. Coating defects. [Online] <https://www.slideshare.net/danielslsa/coating-defects>.
35. Orange Peel. *Defects in Paints*. s.l. : Electrofer Grupo.
36. Using a Wet Film thickness guage. [Online] [https://www.shellac.net/wet\\_mill\\_gauge.html](https://www.shellac.net/wet_mill_gauge.html).
37. Magnetic Induction Process. [Online] <http://www.helmut-fischer.com/en/egypt/knowledge/methods/coating-thickness-measurement/magnetic-induction-process/>.
38. Organograma of Commercial department. *Electrofer Grupo*.
39. Commercial management of construction, 1st edition, guidance note. [Online] April 8, 2016. <https://www.linkedin.com/pulse/commercial-management-construction-1st-edition-guidance-nick-curran>.
40. [Online] <http://slideplayer.com/slide/6516252/22/images/40/Continuum+of+Buyer-Seller+Relationships.jpg>.
41. OWNER'S ROLE AND RESPONSIBILITIES IN THE COMMISSIONING PROCESS. [Online] WBDG Project Management Committee, 11 15, 2016. <https://www.wbdg.org/building-commissioning/owners-role-and-responsibilities-commissioning-process>.
42. **Iowa State University Extension and Outreach, Department of Economics.** Understanding Cash Flow Analysis. [Online] Iowa State University Extension.
43. **Frederick S. Merritt, M. Kent Loftin, Jonathan T. Ricketts.** Construction estimating software. Fourth. s.l. : McGraw Hill, 1996.
44. **Simpkin, J. G.** Management of construction projects. *Project Management Quarterly*. 1976.
45. Understanding and Monitoring the Cost-Determining Factors of Infrastructure Projects. [Online] [http://ec.europa.eu/regional\\_policy/sources/docgener/evaluation/pdf/5\\_full\\_en.pdf](http://ec.europa.eu/regional_policy/sources/docgener/evaluation/pdf/5_full_en.pdf).