

Service restoration on distribution systems using Multi-MicroGrids

F. O. Resende¹, N. J. Gil^{2*}† and J. A. Peças Lopes³

¹*INESC-Porto, Power Systems Unit, Porto, Portugal*

²*Polytechnic Institute of Leiria, Leiria, Portugal*

³*Faculty of Engineering of Porto University, Porto, Portugal*

SUMMARY

Large scale integration of distributed generation of both medium and low voltage (LV) networks can be achieved by exploiting the Multi-MicroGrid (MMG) concept, a new distribution system architecture comprising a hierarchical control system, which allows the coordination among distributed generation units and MicroGrids (MGs) and therefore the operation of such a system in islanded mode. After a general blackout the MMG capabilities can also be used to provide service restoration in distribution systems. A new procedure for MMGs black start is then addressed in this paper. A sequence of control actions is defined and evaluated through numerical simulations. Fully automation of the entire MMG black start procedure is discussed along the paper. The results obtained demonstrate the feasibility of the proposed sequence of control actions and highlight some accomplishments that should be considered in order to successfully restore the MMG service, ensuring system stability and power quality. Copyright © 2010 John Wiley & Sons, Ltd.

KEY WORDS: dynamic behaviour; hierarchical control system; Multi-MicroGrid; sequence of control actions; service restoration

1. INTRODUCTION

Large-scale integration of distributed energy resources (DER) in distribution grids allowed considering the exploitation of these resources to improve the reliability of the grid by considering islanding operation and local service restoration. New architectures and active management strategies for distribution networks have recently been identified as a result of research activities on DER integration, leading to a considerable shift from the traditional central control philosophy to a new more distributed control paradigm [1]. In this context, special attention should be given to both MicroGrids (MGs) and Multi-MicroGrids (MMGs) concepts [2,3].

A MG is commonly defined as a low voltage (LV) distribution feeder plus its loads and several distributed generation (DG) units, in the range of a few tens of kW or even less (usually named as microgenerators), together with an appropriate management and control scheme supported by a communication infrastructure, which is used to monitor and control generation units and loads. Such a system operates mostly interconnected to the medium voltage (MV) network, but can also be operated in an autonomous way if disconnected from the main grid in case of faults on the upstream network, thus providing continuity of supply [4].

The MMG concept is related to a higher level structure, formed at the MV level, consisting of several MG and DG units connected on several adjacent MV feeders, together with controllable MV loads. The coordination of several MG and other DG units requires the adoption of a hierarchical control scheme

*Correspondence to: N. J. Gil, INESC Porto, Portugal.

†E-mail: ngil@estg.ipleiria.pt

that enables the MMG to provide the flexibility and controllability necessary to support secure system operation even when isolated from the upstream high voltage (HV) network [5,6].

Following a general or local blackout, such that the MMG was not able to separate and continue to operate in islanded mode, reduction of interruption times to local consumers can be achieved by exploiting local generation capabilities to provide fast black start at both LV and MV levels and by allowing MMG islanded operation until the upstream HV network is available.

1.1. Conventional service restoration strategies

Although power systems are designed to prevent a total system collapse, their operation close to their technical limits is contributing to increase the risk of major blackouts [7]. Following a general blackout, the normal system operation has to be restored as soon as possible, being the main objective the maximization of restored loads within the minimum elapsed time, while satisfying the required security and operating conditions.

Power system conventional restoration procedures are usually developed before any major disturbance occurs based on results obtained from different numerical simulations. In addition, heuristic approaches reflecting the experience of human operators to deal with the problem are adopted. Furthermore, the size and specific characteristics of each power system precludes the definition of a universal methodology [8]. Therefore, restoration plans are usually defined step by step, based on predefined guidelines and operating procedures, sometimes exploiting decision support tools to assist system operators [9,10].

Two major restoration strategies are well known for their use in transmission systems: the build-up and build-down strategies [8,11]. The first one is based on a top-down sequential restoration of the system skeleton before synchronizing most generators while the second one follows the parallel service restoration of several islands created inside the bulk power system that will then be synchronized later. A combined solution called build-together is also used in certain specific cases [12].

1.2. Service restoration exploiting DG

Although the integration of DG in distribution power system has increased significantly in recent years, the overall approaches to system operation do not fully exploit their potential benefits, namely those concerned with system security and reliability. Current operation practices are based on the principle that DG should not jeopardize the power system operation so that they should be promptly disconnected in case of disturbances, being reconnected only when the distribution circuits are energized and stable values of both voltage and frequency are reached.

Therefore, at the distribution level, service restoration is usually seen as network reconfiguration. Following a fault, the Distribution Management System (DMS) tries to transfer the maximum load from the faulted part to non-faulted part by operating the sectionalizing switches within a feeder or by re-closing the tie-switches between feeders [13,14]. Usually, in the case of major faults, the distribution system must stay in black, generally for several hours, until the transmission system becomes available.

More recently, new approaches have emerged in order to enhance the DG ability to provide additional ancillary services, such as power system restoration. The service restoration strategies will run simultaneously in both transmission and distribution systems. Thus, a conventional strategy is exploited to restore the transmission system while the energization of some islands through DG units with black start capability will allow service restoration expansion at the downstream distribution level. The coordination between transmission and distribution restoration procedures will allow a better reliability, increasing the amount of restored load and reducing the collapsed time [15–19]. Concerning the MG concept, suitable control strategies for MG service restoration and subsequent islanded operation were derived in order to fully automate the entire procedure. The feasibility of this operational concept was already demonstrated in References [18,19] so this task is out of the scope of this paper.

Assuming a large dissemination of the MG concept, local self-healing techniques can be derived, since a MV grid with several MG and other DG units is capable of doing service restoration in its area of influence. The entire power system restoration procedure can then exploit a bidirectional approach: a

conventional top-down philosophy starting from larger power plants restart and transmission system energization and a simultaneous bottom-up strategy, starting from the LV distribution side exploiting MG. At the same time, service restoration on the MV level is carried out by means of local DG units allowing MG synchronization with the upstream MV network in a shorter time interval. In this way the MMG system becomes a resilient network.

This paper tackles with the identification of a sequence of actions to be carried out during MMG service restoration. The possibility of developing a fully automated MMG restoration procedure is also addressed in this paper. For these purposes, the control strategies proposed in References [5,6] are exploited together with a MMG communication infrastructure that is supposed to be available.

In order to study and evaluate the technical feasibility of the proposed sequence of actions to carry out MMG service restoration, two simulation platforms are exploited to deal with the study case network. Issues related with network energization and small islands synchronization are analysed in a simulation platform developed under *EMTP-RV*[®] environment, while an *EUROSTAG*[®] based simulation platform is used to evaluate the longer term dynamic behaviour concerning the remaining actions to be carried out on the islanded MMG.

2. THE OPERATIONAL AND CONTROL ARCHITECTURES OF MG AND MMG

As stated before, the MMG concept, which has been developed within the framework of the EU More MGs Project [2], comprises several MG and DG units connected at several MV feeders. In turn, the MG concept, developed within the framework of the EU MGs Project [3], is a typical LV distribution network connected to the secondary winding of the MV/LV distribution transformer, as depicted in Figure 1. It comprises several feeders supplying electrical loads and several small modular generation units connected to them through power electronic interfaces. These microgeneration systems would be typically based on renewable energy sources. Storage devices are also included in order to provide power balance during transients [4].

As it can be observed from Figure 1, a MG also includes a hierarchical control and management structure headed by the MicroGrid Central Controller (MGCC). It communicates with local controllers of microsources and storage devices, the Microsources Controllers (MC), as well as Load Controllers (LC) [4].

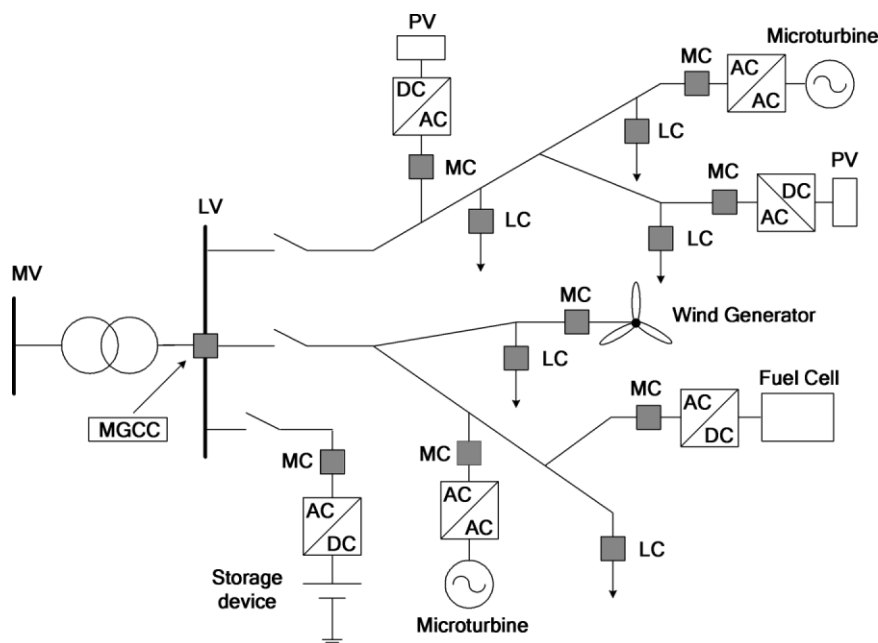

Figure 1. MicroGrid architecture comprising microsources, storage devices, loads and control devices.

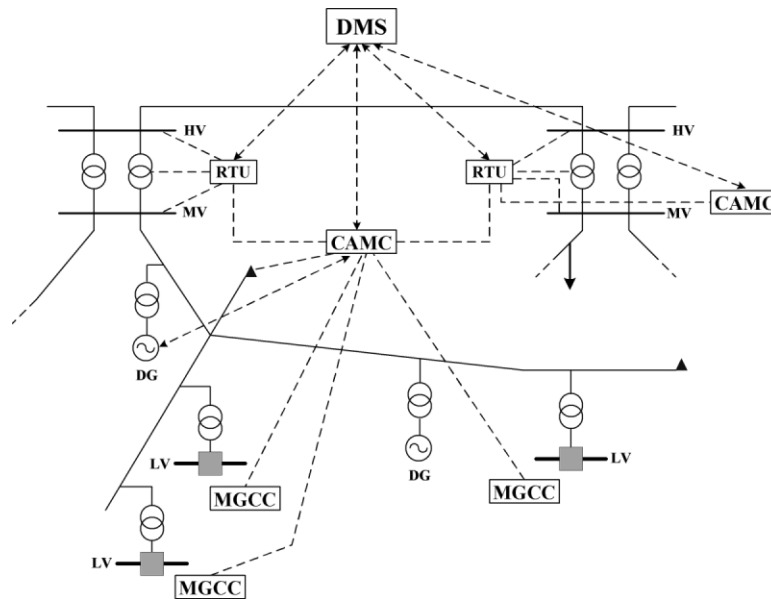

Figure 2. Control and management architecture of a Multi-MicroGrid.

As already mentioned, this hierarchical type management and control scheme, supported by a communication infrastructure, is used to monitor and control microgeneration systems and loads, ensuring the MG operation as a single and active cell from the viewpoint of the upstream MV system. Thus, the MG can be operated interconnected to or isolated from the upstream MV network. Being an autonomous entity, the MG can also perform black start functions in the event of the failure of the upstream network and the failure of an automatic islanding. The feasibility of a MG service restoration is identified in References [18,19].

The MMG concept is related to a higher level structure, formed at the MV level. The possibility of having a large number of controllable Microgrids, DG units and MV loads requires the use of a hierarchical control scheme that enables an efficient control and management of this kind of system. This new control and management architecture, which is represented in Figure 2, allows the MMG operation under both normal interconnected and emergency mode in a similar way that a MG.

For this purpose, the Central Autonomous Management Controller (CAMC) installed at the MV bus level of a HV/MV substation under the responsibility of the DMS plays a key role. The management of the MMG will be performed through the CAMC, acting as an intermediate management control structure that will receive information from the upstream DMS, measurements from MV networks, Remote Terminal Units (RTU) and from the existing MGCC. In addition, it will have to deal with constraints and contracts to manage the MMG in both HV interconnected and emergency modes of operation. This requires tackling with the following features: state estimation, coordinated voltage support and flow control, coordinated frequency support and emergency functions [3]. Therefore, the control and management architecture together with the CAMC emergency functionalities allow a coordinated use of the DG units, which is essential to restore the MMG system.

3. MULTI-MICROGRID CONTROL FOR BLACK-START

Under this framework, service restoration is performed by the CAMC, going through several stages, like: building the MV network, forming and operating both MV islands and MG, controlling voltage and frequency, synchronizing islands and MG in order to form the MMG system, connecting loads, operating the MMG in islanded mode and conduct the subsequent synchronization with the upstream system when service is restored on the HV side.

The CAMC is used for secondary frequency control in case of MMG islanding and also for load following in islanded operation. In order to balance generation and load, the CAMC generates set points based on system frequency changes and sends them to the MGCC, to independent DG units and also to controllable MV loads in an attempt to ensure MMG system operation near an optimum point [5,6]. In turn, the MGCC act as intermediate controllers between the CAMC and the internal controllers of MG such as MC and LC, so that the CAMC doesn't have to know the MG composition. Each MGCC is responsible for scheduling the corresponding power change among the MG controllable loads and microgeneration units by sending set points to the LC and MC, respectively. MGCC are also responsible for guiding the MG black start procedure.

Whenever a general blackout occurs, the MMG black start sequence will be automatically conducted under CAMC control. In this context, the information exchange between the CAMC and local controls during the MMG black start procedure involves mainly switching orders so that the MV network can be rebuilt and also commands to connect DG units and loads. General monitoring information (e.g. voltage levels, grid status) must also be received by the CAMC. Verification of synchronization conditions is performed locally.

During the initial stages of the MMG service restoration, the balance between generation and load is critical so that large voltage and frequency excursions should be prevented. Otherwise the success of the restoration procedure could be compromised. For this purpose both controllable and uncontrollable loads should be disconnected from the MV network and, therefore, it should be possible to remotely control all the MV loads in order to efficiently manage load switching.

4. POWER SYSTEM MODELLING

In order to simulate the dynamic behaviour of the MMG system during the restoration procedure and subsequent operation in islanded mode, mathematical models for the several components are required. MMG components comprise DG units connected to the MV network, microgeneration systems connected to the LV network forming the MG, distribution transformers, lines and loads.

As already mentioned previously, *EUROSTAG*[®] and *EMTP-RV*[®] simulation platforms are used to simulate the MMG dynamic behaviour during system restoration. Thus, some of the mathematical models of MMG system components, such as distribution transformers, branches and loads, came from the libraries of these simulation tools. However, most of the less common models were not available on the versions in use and had to be implemented. The mathematical models of these components are briefly described in the following subsections.

4.1. Modelling of DG units connected to the MV network

DG units connected to the MV network can comprise wind farms (in this case considered to be equipped with doubly-fed induction machines—DFIM), hydro units with conventional induction generators, Combined Heat and Power (CHP) units, small diesel generators, both equipped with synchronous generators, and storage devices interfaced with power electronic voltage source inverters (VSI) type units.

The mathematical model that describes the dynamic behaviour of the DFIM is based on the approach described in Reference [20] with additional modules for pitch and de-load control which enable it to participate in primary frequency regulation [21]. These control systems enable the adjustment of both turbine speed and power factor, so that the machine can be operated at an optimum operation point and, if properly controlled, it could provide voltage VAR support and primary frequency control.

An automatic voltage regulator (AVR), IEEE type 1 model [22] was included to provide the field voltage to the synchronous machine in order to maintain terminal bus voltage at a desired value. The power output is adjusted according to set points sent by the CAMC.

The VSI is represented as a power injector and is controlled to emulate the behaviour of a synchronous machine, so it is equipped with a proportional controller which allows the injection or absorption of active power when the system frequency deviates from its nominal value [5,6].

4.2. Modelling of microgeneration systems

MG can include microturbines, fuel cells, small wind generators, photovoltaic systems connected to the LV grid through a VSI and storage devices. Storage devices play a key role in the MG operation as they are the elements that provide energy in order to ensure system stability during islanded operation and particularly in the service restoration procedure [4,18,19]. Considering the time period under analysis, storage devices are modelled as constant DC voltage sources using VSI to be coupled with the LV network.

The mathematical model adopted to represent the dynamic behaviour of the single shaft microturbine is based on the GAST microturbine model presented in Reference [23], since it is expected to be reasonably representative of the technologies available for use regarding these systems. The microturbine model also includes a permanent magnet synchronous generator coupled to the strictly mechanical components and a control system similar to that of the DFIM controller. In fact, the power interface controllers force the stator voltage in order to establish rotation speeds corresponding to the operating points near to those specified as the optimum by the machine operating curve.

Concerning fuel cells, as this kind of technology is still under heavy study in order to attain ever better process enabling the widespread commercial usage it is difficult to know which technologies will become prevalent in the future. However, it is expected that the Solid Oxide Fuel Cell (SOFC) technology will be representative of this kind of power generators. So, in this work, the SOFC model described in Reference [23] was adopted.

The micro wind generator model is considered to be an induction machine directly connected to the LV grid [4]. Regarding photovoltaic systems, it was assumed that the system is always working at its maximum power for a given irradiance and temperature. This corresponds to an empirical model based on experimental results, as described in Reference [24].

5. MULTI-MICROGRID BLACK START

The MMG restoration procedure will be triggered if a general or local blackout occurs or if major injuries affecting the HV upstream system do not allow feeding the MMG from the HV side after a pre-defined time interval. The CAMC should also receive information from the DMS about the service restoration status at the HV level in order to help deciding to launch the MMG black start procedure.

The MMG service restoration procedure is performed under the CAMC control and comprises the following main stages:

- (1) building MV network;
- (2) forming islands;
- (3) synchronization of islands;
- (4) load connection/connection of non-controllable DG units directly connected to the MV grid.

A set of specific tasks needs to be carefully carried out for building the MV network. Such tasks are considered as a sequence of actions such as starting DG units with black start capability and energizing electrical paths as well as a large number of distribution transformers. The DG unit responsible for this task should have the capacity to absorb reactive power for reducing possible over voltages at the point of line terminals, since it may be necessary to deal with the energization of unloaded MV cables.

As several DG units with black start capability and MG are present in a MMG system, several islands can be formed. After MV network energization, islands may be synchronized in order to form a large island and therefore the entire MMG system being operated in islanded mode. In order to avoid large transient currents and power exchanges the synchronization conditions should be verified by matching phase sequence, frequency and voltage of both sides of the corresponding switches.

When islanded, the MMG hierarchical control system provides voltage and frequency stabilization. When the system frequency is larger than the nominal frequency additional load can be connected to the MV network. The amount of additional load to be connected is determined according to the generation capacity. When the HV upstream system is available, the MMG will be synchronized by checking the synchronization conditions.

The CAMC will guide the MMG service restoration based on information about the last MMG load scenario, which is stored in a data base, and on the set of rules identified in advance and embedded into the CAMC software. Thus, MMG controllers and communication infrastructures are of the utmost importance for the MMG restoration procedure success. Therefore, small auxiliary power units are required to power the communication network elements and controllers allowing the availability of bidirectional communication between the CAMC and both the MGCC of each MG and controllers of DG units.

Beyond these essential conditions, a set of general assumptions should be taken into account in order to carry out a successfully MMG black start procedure.

5.1. General assumptions

As the CAMC will try to restore the last MMG load scenario, it is assumed that updated information is available, obtained just before the disturbance, about the status of load and generation in the MMG and about availability for DG units connected to the MV network to restart.

In addition, it is also assumed that there is availability for preparing the network for energization. For this purpose, after the system collapse, the following requirements should be taken into account:

- The MMG is disconnected from the upstream HV network.
- The MMG feeders are fully sectionalized.
- MG are disconnected from the MV network.
- DG units and loads are disconnected from the MV network.
- The HV/MV transformer is disconnected from the HV and MV networks.
- All the MV/LV transformers are disconnected from the MV and LV networks.
- All the reactive power sources such as shunt capacitor banks are switched off.

During the MMG service restoration procedure it was assumed that all the MG inside the MMG have availability for black start and the DG units connected to the MV network with black start capability are the Diesel group and the CHP units. It is also assumed that the automatic secondary frequency control system embedded into the CAMC software is turned off.

5.2. Sequence of actions for MMG service restoration

After a general blackout the CAMC will perform service restoration in a MMG based on information stored in a data base about the last MMG load scenario, as described before, by performing the following sequence of actions:

- (1) Disconnect all loads, sectionalize the corresponding MV/LV transformers and switch off the reactive power sources. After a general blackout, all the loads, transformers and shunt capacitor banks should be disconnected in order to avoid large frequency and voltage deviations when energizing the MV network.
- (2) Sectionalizing the MMG around each MG and around each DG unit with black start capability. These actions lead to the creation of small islands inside the MMG, since after MG black start they are operated in islanded mode feeding some amount or its own entire load and both the Diesel group and CHP units are supplying their protected loads. These islands will be afterwards synchronized with the MV network.
- (3) Building the MV network. The Diesel group is used to energize the initial part of the MV network, which comprises the unloaded transformer downstream the Diesel group and some paths which allow to synchronize CHP islands (CHP units feeding its own loads) or to feed important loads. The energization of the initial part of the MV network is carried out step by step in order to avoid large voltage and frequency deviations. Thus the transformer downstream the Diesel group is energized first, some MV branches are energized afterwards, followed by the MV/LV transformers upstream the CHP units.
- (4) Synchronization of CHP islands with the MV network. Each one of the CHP islands can be synchronized with the MV network when the corresponding path is energized in order to

- strengthen the MMG system. The synchronization conditions (phase sequence, frequency and voltage differences) should be verified in order to avoid large transient currents.
- (5) Connection of some amount of important load. Connection of important loads is performed if the DG units connected to the MV network have the capability to supply these loads. The amount of power to be connected should take into account the generation capacity in order to avoid large frequency and voltage deviations during load connection.
 - (6) Energization of the remaining MV branches and the MV/LV transformers upstream the MG. At this stage the CHP islands are already synchronized and the MMG is strong enough to energize the remaining branches of the MV network. However, as the MMG comprises a large number of MV/LV unloaded transformers, their energization should be carried out in several steps in order to avoid large inrush currents. Thus, the MV/LV transformers upstream the several MG are energized first in order to allow the MG synchronization with the MV network.
 - (7) Synchronization of MG with the MV network. MG operated in islanded mode can then be synchronized with the MV network. For this purpose the synchronization conditions should be verified.
 - (8) Energization of the remaining MV/LV transformers. In order to start restoring the load, the MV/LV unloaded transformers should be energized. They are divided into several groups which are energized with different timings in order to avoid large inrush currents. Afterwards the MV/LV transformers upstream the uncontrollable DG units are also energized.
 - (9) Load restoration. At this stage the MV network is fully energized and some loads can be connected depending on the generation capacity.
 - (10) Connection of uncontrollable DG units connected to the MV network. As the MMG has sufficient strength to smooth voltage and frequency variations due to power fluctuations in non-controllable DG units, they can now be connected to the MV network. MV paths are also created so that DG units without black start capability can absorb power from the grid in order to restart.
 - (11) Load increase. In order to feed as much load as possible other loads can then be connected.
 - (12) Activation of the automatic frequency control. The automatic frequency control is now activated in order to assure the MMG system frequency near its nominal value while the MMG is operated in islanded mode.
 - (13) MMG reconnection to the upstream HV network when it becomes available. When the CAMC requires the MMG synchronization with the HV system, the synchronization conditions should be verified. The HV/MV transformer should be previously energized from the HV side and the synchronization is performed through MV switches.

6. TEST SYSTEM AND SIMULATION PLATFORMS

The adopted test network represents what could be a typical structure of a MV grid containing multiple MG and several kinds of DG units connected to the MV feeders, as can be observed from Figure 3.

In this network four zones can be identified: two rural and two urban zones connected to the HV/MV substation. A large number of MG can also be found all connected to MV buses and some other typical DG systems: a small Diesel group, several CHP and mini-hydro units, two DFIM corresponding to wind generator systems and a storage device (either a large flywheel or a set of batteries) electronically interfaced with the MV network using a VSI control responding to frequency changes, as described in Reference [4].

All the MG have a 150 kW/50 kVar equivalent controllable load and also the same mix of micro generation systems: a small wind generator, a SOFC, a microturbine, a photovoltaic system and a storage device connected to the LV grid through a VSI.

There are also some capacitor banks at the MV level that are used for two purposes: to improve the voltage profile throughout the network and to provide sufficient reactive power to balance reactive generation and reactive load under MMG islanded operation.

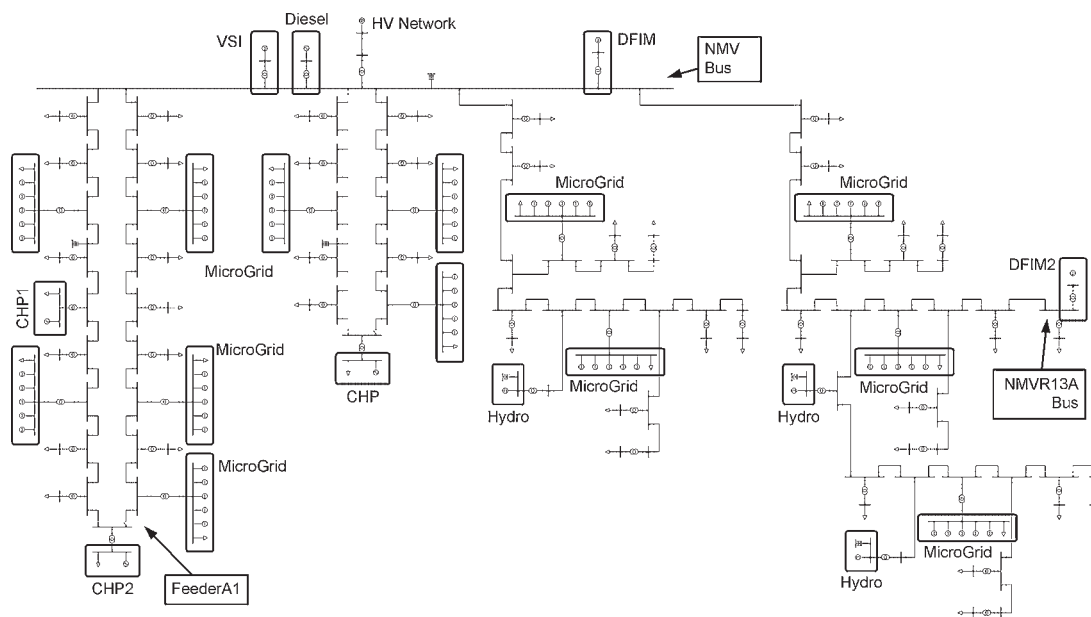

Figure 3. Test system.

7. SIMULATION RESULTS AND DISCUSSION

The feasibility of the proposed sequence of control actions to be carried out for MMG service restoration is demonstrated in this section of the paper through numerical simulations. For this purpose it was assumed that a general blackout took place and was followed by the subsequent set of actions:

- disconnection of the MMG from the HV/MV transformer;
- disconnection of MG from the MV/LV distribution transformers;
- disconnection of both MV loads and MV renewable energy sources;
- MMG sectionalization around each DG unit with black start capability and MG;
- automatic creation of MV islands and MG being operated autonomously;
- capability to operate both the restarted DG units and MG in islanded mode supplying only their associated loads.

In the MMG restoration procedure the two most important stages are

- building the MV network and synchronization of small islands;
- load supply and integration of generation.

In what concerns the first stage, the skeleton paths of the MV network are energized and DG units supplying their protected loads can be synchronized. Then, some load should be restored in order to balance generation and to stabilize voltage. In this stage the main problems to deal with are voltage profiles and switching operations as a consequence of energizing unloaded MV paths and a large number of unloaded distribution transformers.

In the second stage, load is restored according to generation requirements and MG can be synchronized. Other DG units based on renewable energy sources can also be connected to the MV network. Here, the main problems to deal with are active and reactive power balance, overloads and prime movers response to sudden load pick-up. However, the voltages must also be kept within acceptable limits during the load supply stage and power balance should be respected during the MV network building.

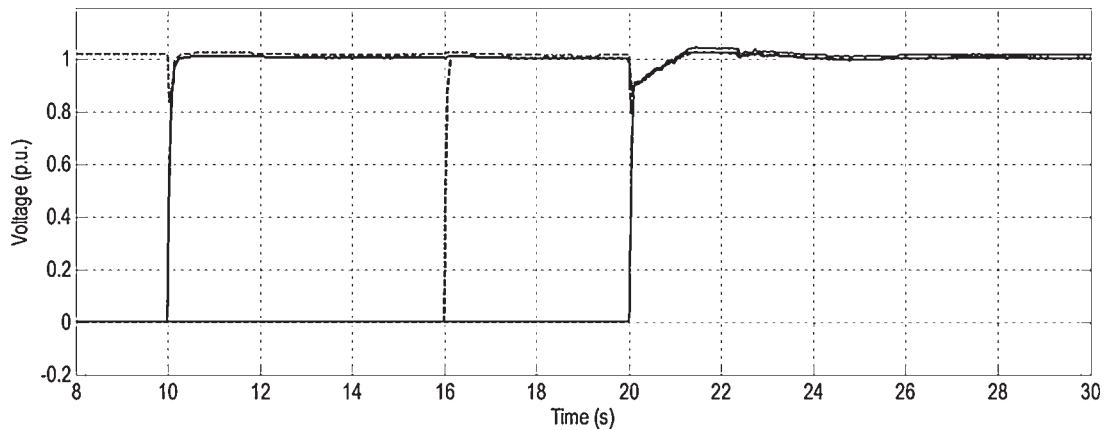

Figure 4. Bus voltages following the first steps of FeederA1 energization.

7.1. Building MV network and synchronization of small islands

In order to simulate the sequence of actions concerned with MV network energization and synchronization of small islands a simulation platform developed under *EMTP-RV*[®] environment was used. As the Diesel group and CHP units can restart successfully without network support, it was assumed that these units are already running and feeding their own loads. The Diesel group was selected to energize the initial part of the MV network in order to create paths to synchronize the islands formed by CHP units. Then at $t = 10$ seconds the transformer downstream the Diesel group is energized. The FeederA1 of the test system is energized at $t = 16$ seconds followed by the energization of the MV/LV transformer upstream the CHP1 unit at $t = 20$ seconds. Following this first sequence of actions, the voltages of the target buses of FeederA1 already energized are presented in Figure 4.

When energizing the lines of the FeederA1 a very small voltage increase is verified at the end of the unloaded feeder. The inrush current required during the unloaded transformers energization is responsible for transient voltage drops. However, bus voltages are kept within acceptable limits, as it can be observed from Figure 4.

Following the assumptions mentioned previously, both CHP1 and CHP2 units restarted successfully and were operated in standalone feeding their own loads. The operating frequency of the islands formed by the Diesel group and by the two CHP units is presented in Figure 5.

The Diesel group frequency variations observed in Figure 5 are caused by the energization, using this machine, of the unloaded transformers already mentioned. The frequencies concerning the other two islands are kept near a constant value which depends on the supplied load.

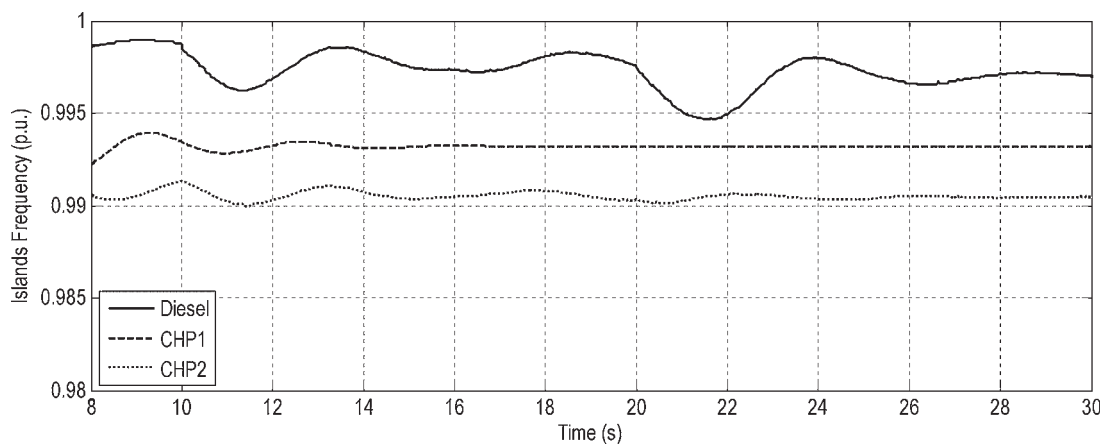

Figure 5. Frequency of the islands formed during the first steps of FeederA1 energization.

In order to continue with the MV network energization the following sequence of actions was simulated:

- synchronizing the CHP1 island with the MV network ($t = 11.2$ seconds);
- synchronizing the CHP2 island with the MV network ($t = 15$ seconds);
- energizing the MV/LV transformers upstream the MG ($t = 20$ seconds);
- energizing the first group of MV/LV transformers upstream the loads ($t = 30$ seconds);
- energizing the second group of MV/LV transformers upstream the loads ($t = 40$ seconds);

The CAMC is responsible to send orders to the controllers of both CHP1 and CHP2 units for synchronization of the corresponding islands with the MV network. For this purpose the synchronization conditions are checked locally by each unit controller. In this case the controller of CHP1 received first the CAMC request for island synchronization. After its synchronization a new request is sent to the CHP2 controller. The synchronization conditions concerning CHP1 and CHP2 units are met at $t = 11.2$ and 15 seconds, respectively.

The feasibility of these control actions can be observed from Figures 6–8. In fact, the impact of these control actions on the MV network voltage and frequency is negligible. This is also demonstrated through the active power exchange presented in Figure 8.

After both islands synchronization, the MMG service restoration proceeds with the energization of the MV/LV distribution transformers of FeederA1. In order to prevent large inrush currents and therefore large voltage drops inside the MMG system, this task is performed by steps. Thus, three

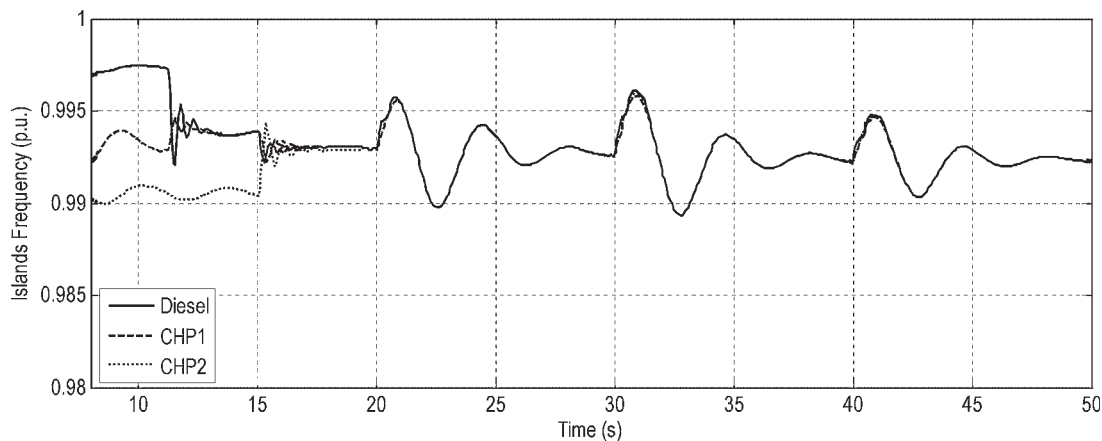

Figure 6. Islands frequency following the remaining steps of FeederA1 energization.

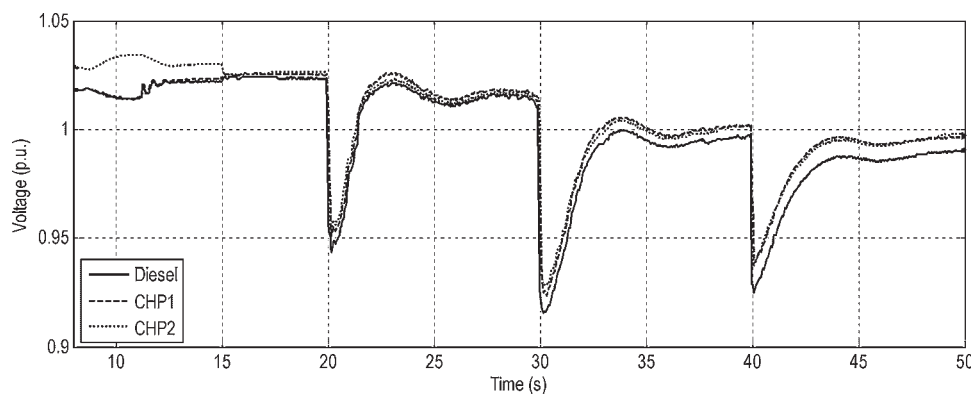

Figure 7. Terminal bus voltages of Diesel group and CHP units following the remaining steps of FeederA1 energization.

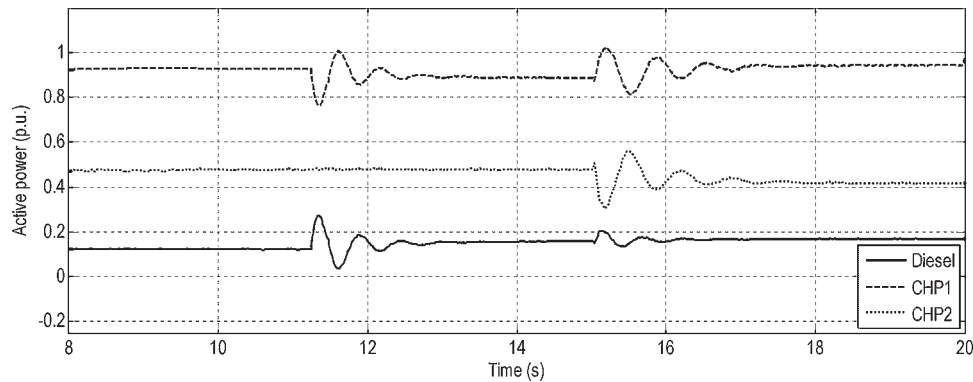

Figure 8. Active power supplied by the Diesel group and CHP units.

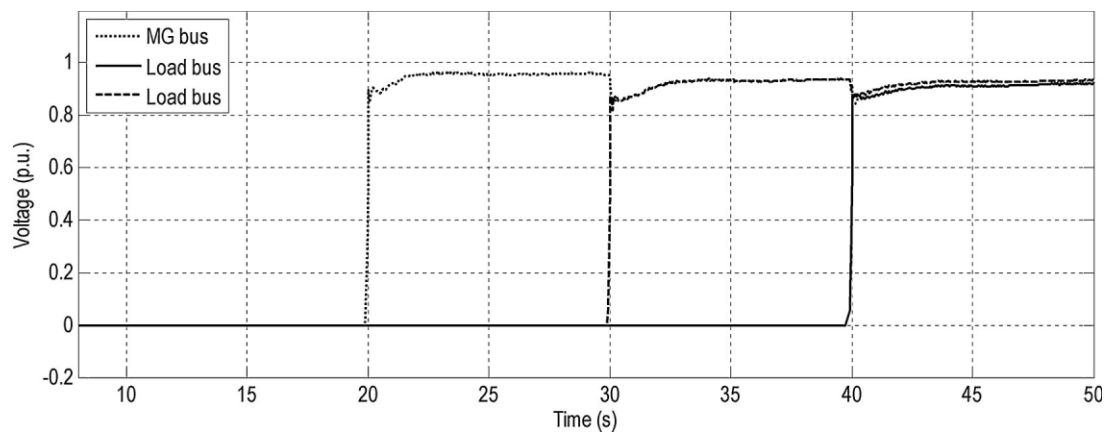

Figure 9. Voltage at the LV side of transformers located upstream the MG and loads.

groups of transformers were considered and energized at different timings according to a given priority. The first group to be energized, at $t = 20$ seconds, comprises the transformers located upstream the several MG. The other two groups, energized at $t = 30$ and 40 seconds comprise the transformers located upstream the loads. The impact of these control actions on the MV network can also be observed from Figures 6 and 7. The procedure adopted allows the system frequency and bus voltages to be kept within acceptable limits.

Figure 9 shows the voltage magnitude of several LV buses after the MV/LV transformers energization. It can be verified that the voltage drops due to the energization of unload transformers are within acceptable limits and, after the transient periods, the voltages at the LV buses are near their nominal values.

The results obtained demonstrate the feasibility of the first steps of the proposed sequence of actions for building the MV network. It should be noted that these results correspond to the worst case since in the early steps of the MV network energization the weakness of the MMG system makes it more vulnerable.

7.2. Load supply and integration of generation

In order to get an extended overview of the dynamic behaviour resulting from the overall MMG system restoration procedure, the *EUROSTAG*[®] simulation platform was used. The simulations to be carried out start from a scenario as close as possible from the one left off by the *EMTP-RV*[®] simulations, after all the feeders are energized and not only the one described in detail in the previous set of results. The

MMG network is thus considered to be completely energized and all the CHP units are synchronized with the MV network.

Each of the power production systems that have directly associated loads are considered to be initially generating just the necessary power to supply these loads. These power production systems include the CHP units and the several MG present in the test network and their net contribution for the MMG is, therefore, negligible. The MMG service restoration proceeds with load supply and integration of DG units, other than the CHP units.

Load should be restored step by step according to the integrated generation capacity. As the secondary frequency control is disabled, every load pick-up results in a system frequency drop. So, it is necessary to connect DG units as the amount of the restored load increases in an attempt to replace the secondary frequency control as long as it is disabled. For this purpose, when the CAMC observes system frequency more than the nominal frequency, power is available to connect additional load and therefore, depending on the system capacity, the CAMC determines the amount of additional load to be connected.

At the end of the black start sequence ($t = 900$ seconds), after every load is connected to the MMG, the automatic secondary frequency control is activated. The frequency value recovers quite rapidly back to the rated value of 50 Hz and load changes that may occur afterwards will not cause long-term frequency deviations because the MMG load-following capabilities are already restored. It is thus possible for the MMG to resume operation from this point forward in a robust way, while still in isolated mode, even before being reconnected to the upstream HV grid.

The frequency variation in the MMG during the second stage of the MMG black start sequence can be seen in Figure 10. The maximum frequency deviations never surpass 0.5 Hz, which is a consequence of the careful choice of the steps taken throughout the full black start sequence.

It can also be seen that the whole sequence could be made much shorter. In fact, much time was spent waiting for the frequency to stabilize in order to better visualize the individual contributions of the several sources and the frequency drops originated by each of the loads being connected.

The VSI connected to the MV network provides some power balance during transients contributing thus to frequency control, as can be observed from Figure 11. It is clearly visible the effect the threshold has on the VSI power output, because it hovers around zero for large periods of time even when the frequency is clearly far from the rated value. However, this is necessary to prevent the storage element to completely discharge or fully charge, which would stop it from carry out its job correctly.

As mentioned previously, voltage levels can easily become problematic in distribution networks. To illustrate this statement, Figure 12 presents the voltage values in two of the network MV nodes during all the second stage of the MMG black start sequence.

The NMVR13A bus is located in a weak sector of the network (Figure 3) near the DFIM2 wind park (3 MW). The radial nature of the network at this point clearly poses difficulties towards letting the active power flow to other areas of the network. This problem can be perceived by the sudden increase in the bus voltage of NMVR13A, which follows the increase of the production of the DFIM2 wind park, at around $t = 300$ seconds.

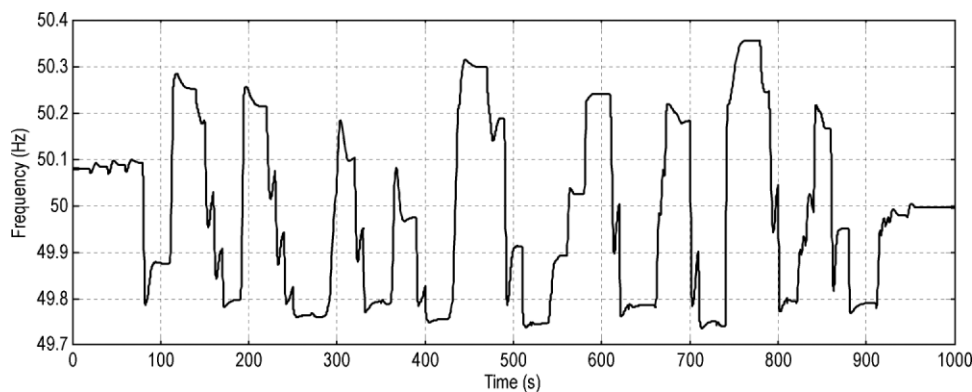

Figure 10. Frequency variation during the MMG black start sequence.

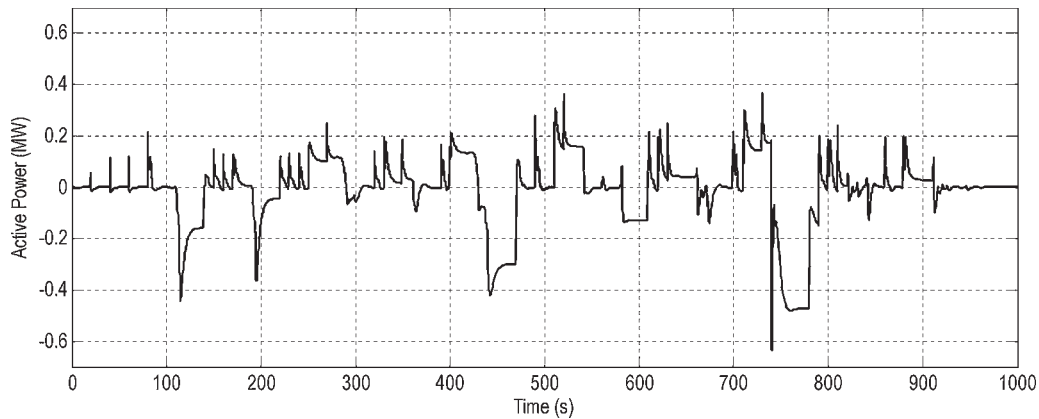

Figure 11. Contribution of the MV connected VSI for frequency control.

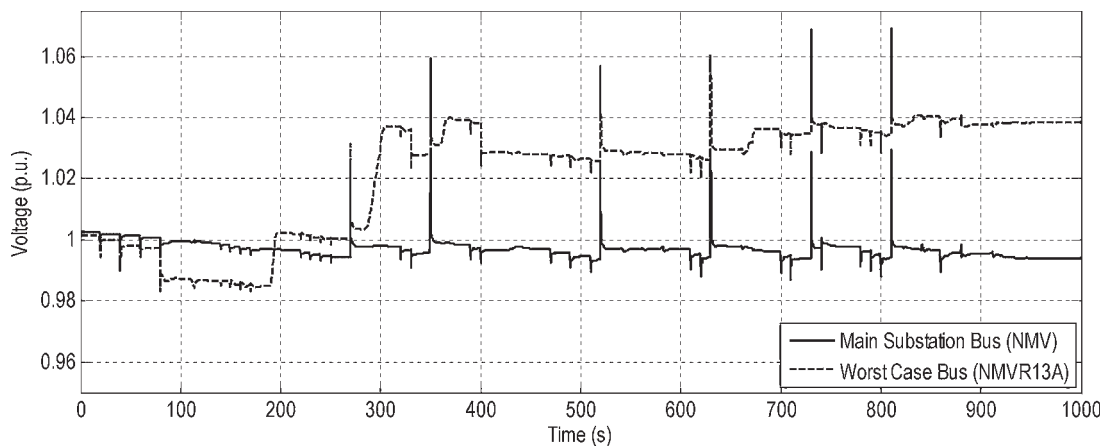

Figure 12. Voltage variation during the black start sequence.

The NMV bus is located in a strong part of the test network, where the active power has a lot of pathways and can easily reach the loads that require it. The problem here is more related to the lack of reactive power and the corresponding drop in the voltage value. This can be corrected in several already mentioned ways: standard synchronous generators with voltage regulators, capacitor banks and the DFIM wind park with activated voltage regulators.

In this case, the synchronous generators cannot take care of the problem on their own. They are completely overpowered because of their small number and must have the help of other different units. Therefore, it was necessary to use the capacitor bank connected to the HV/MV substation bus, switching its steps whenever necessary to keep the voltage as stable as possible. It is, however, necessary to be careful with the voltage transients that occur when these steps are switched on and these transients might need to be taken into account when setting network protections.

SVC devices can be of great help in this kind of application, particularly because they allow the synchronous machines to generate less reactive power. Their application in this kind of scenario can be difficult to justify. However, the DFIM wind park has in its controller the necessary capabilities to perform this kind of function.

Figure 13 shows the reactive power that the DFIM wind park injects on the network in order to keep the voltage on its connection node at the rated value. Taking into account that we were talking about a 6 MW wind park, the contribution is not disproportionate and is sufficient to keep other HV/MV bus generators (e.g. the Diesel unit) from working excessively near their thermal limit.

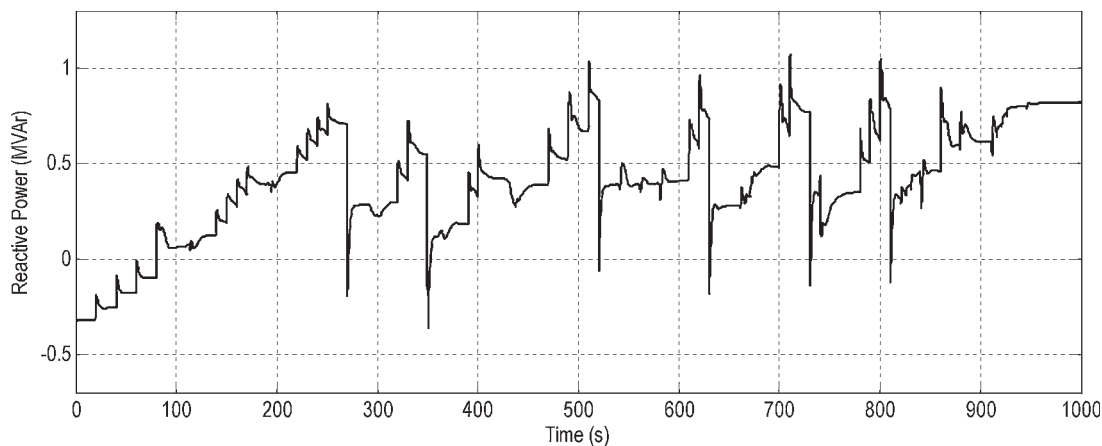

Figure 13. Contribution of the MV connected DFIM (wind park) for voltage control.

8. CONCLUSIONS

In this paper the sequence of control actions to be adopted for MMG service restoration and subsequent operation in islanded mode were derived and evaluated through numerical simulations. The results obtained demonstrated the technical feasibility of using the MMG concept to improve service restoration procedures on distribution systems allowing the reduction of load restoration times. Islanded operation of parts of the MV grid during the restoration sequence has a key role in the success of this procedure. In addition, MMG service restoration can be considered as a great opportunity to take advantage of generation systems traditionally considered as non-controllable as support to the load supply. Based on the MMG hierarchical control system and exploiting the MMG communication infrastructure, the entire MMG service restoration procedure can be fully automated.

However, the following issues should be taken into account in order to ensure an effective and successful MMG black start:

- Availability of, at least, one DG unit connected with the MV network with black start capability to be used as the grid forming unit. This DG unit plays a key role on the first stages of the MMG service restoration and should have capability to provide both voltage and frequency regulation autonomously.
- Capability to check locally the synchronization conditions as well as the existence of synchronization devices.
- Energization of the large amount of unloaded MV/LV transformers have to be carried out in several steps in order to avoid large inrush currents and therefore large voltage drops inside the MMG during the first stages of the restoration procedure.
- Voltage control should take into account that voltage levels near the generation sites can rise to very high values, since in this kind of weak distribution networks the electrical distance between generation and load can be very large.

5. LIST OF ABBREVIATIONS

LV	Low Voltage
MMG	Multi-MicroGrid
MG	MicroGrid
DER	Distributed Energy Resources
DG	Distributed Generation
MV	Medium Voltage
HV	High Voltage
DMS	Distribution Management System

MGCC	MicroGrid Central Controller
MC	Microsource Controller
LC	Load Controller
CAMC	Central Autonomous Management Controller
RTU	Remote Terminal Unit
DFIM	Doubly-Fed Induction Machine
CHP	Combined Heat and Power
VSI	Voltage Source Inverter
AVR	Automatic Voltage Regulator
GAST	Gas Turbine
SOFC	Solid Oxide Fuel Cell

REFERENCES

1. European Commission - Directorate General for Research. Towards smart power network: Lessons learned from European Research FP5 projects. ISBN 92-79-00554-5, European Communities, 2005.
2. European Research Project MicroGrids. Available online at: <http://microgrids.power.ece.ntua.gr>
3. European Research Project More MicroGrids. Available online at: <http://microgrids.power.ece.ntua.gr>
4. Lopes JAP, Moreira CL, Madureira AG. Defining control strategies for MicroGrids islanded operation. *IEEE Transactions on Power Systems* 2006; **21**(2):916–924.
5. Gil NJ, Peças Lopes JA. Exploiting automated demand response, generation and storage capabilities for hierarchical frequency control in islanded multi-microgrids. *Proceedings of PSCC2008, 16th Power System Computation Conference*, Glasgow, Scotland, August 2008.
6. Gil NJ, Peças Lopes JA. Hierarchical frequency control scheme for islanded Multi-Microgrids operation. *Proceedings of IEEE Lausanne PowerTech2007*, IEEE Lausanne PowerTech2007, Lausanne, Switzerland, August 2007.
7. Adibi MM, Kafka RJ. Power system restoration issues. *IEEE Computer Application in Power* 1991; **4**(2):19–24.
8. Adibi MM, Fink LH, Andrews CJ, Arsanjani F, Lanier MW, Miller JM, Volkman TA, Wrubel J. Special consideration in power system restoration. *IEEE Transactions on Power Systems* 1992; **7**:1419–1427.
9. Adibi MM, Kafka RJ, Milanicz DP. Expert system requirements for power system restoration. *IEEE Transactions on Power Systems* 1994; **9**:1592–1600.
10. Ancona JJ. A framework for power system restoration following a major power failure. *IEEE Transactions on Power Systems* 1995; **10**:1480–1485.
11. Adibi MM, Fink LH. Power system restoration planning. *IEEE Transactions on Power Systems* 1994; **9**:22–28.
12. Fink LH, Liou KL, Liu CC. From generic restoration actions to specific restoration strategies. *IEEE Transactions on Power Systems* 1995; **11**(2):745–752.
13. Hayashi Y, Matsuki J. Loss minimum configuration of distribution system considering N-1 security of dispersed generators. *IEEE Transactions on Power Systems* 2004; **19**(1):639–642.
14. Choi JH, Kim JC, Moon S. Integrating operation of dispersed generation to automated distribution networks for network reconfiguration. *Proceedings of IEEE 2003 Bologna PowerTech Conference*, Bologna, Italy, 2003.
15. Ha Pham TT, Bésanger Y, Andrieu C, Hadjsaid N, Fontela M, Enacheanu B. A new restoration process in power systems with large scale of distributed generation. *Proceedings of 2005/2006 IEEE PES Transmission and Distribution Conference and Exposition*, Dallas, May 2006.
16. Pham TTH, Bésanger Y, Hadjsaid N, Ha DL. Optimizing the re-energizing of distribution systems using the full potential of dispersed generation. *Proceedings of the IEEE 2006 Power Engineering Society General Meeting*, 2006.
17. Pham TTH, Bésanger Y, Hadjsaid N. New challenges in power system restoration with large scale of dispersed generation insertion. *IEEE Transactions on Power Systems* 2009; **24**(1):398–406.
18. Moreira CL, Resende FO, Peças Lopes JA. Using low voltage microgrids for service restoration. *IEEE Transactions on Power Systems* 2007; **22**:395–406.
19. Peças Lopes JA, Moreira CL, Resende FO. MicroGrids black-start and islanding operation. *Proceedings of the 15th PSCC*, Liège, Belgium, 2005.
20. Slootweg JG, Polinder H, Kling WL. Dynamic modelling of a wind turbine with doubly fed induction generator. *IEEE Power Engineering Society Summer Meeting* 2001; **1**:644–649.
21. de Almeida R, Peças Lopes J. Participation of doubly fed induction wind generators in system frequency regulation. *IEEE Transactions on Power Systems* 2007; **22**:944–950.
22. Kundur P. *Power System Stability and Control*. McGraw-Hill: New York, 1994.
23. Zhu Y, Tomsovic K. Development of models for analyzing the load-following performance of microturbines and fuel cells. *Electric Power Systems Research* 2002; **62**:1–11.
24. Hatzigiargyriou N, Jenkins N, Lopes JAP, et al. Modelling of micro-sources for security studies. *Proceedings of CIGRE Session*, 2004.